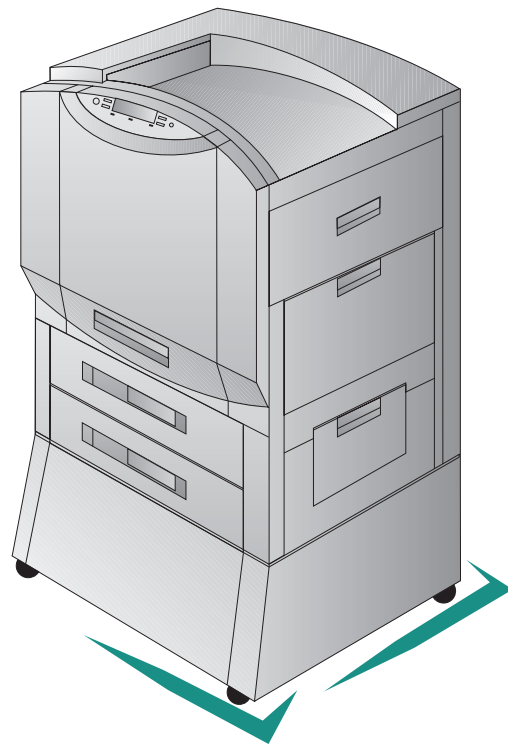




*Color*   
*LaserJet™*  
*8500, 8500 N, 8500 DN Printer*

**Service Manual**





HP Color LaserJet 8500,  
8500 N, 8500 DN Printer

**Service Manual**

---

## Copyright Information

© 1998 Hewlett-Packard  
Company

All Rights Reserved.  
Reproduction, adaptations, or  
translation without prior written  
permission is prohibited except  
as allowed under copyright  
laws.

Part number C3983-90954

First edition, October 1998

Printed in USA

## Warranty

The information contained in  
this document is subject to  
change without notice.

Hewlett-Packard makes no  
warranty of any kind with  
respect to this information.  
HEWLETT-PACKARD  
SPECIFICALLY DISCLAIMS  
THE IMPLIED WARRANTY OF  
MERCHANTABILITY AND  
FITNESS FOR A  
PARTICULAR PURPOSE.

Hewlett-Packard shall not be  
liable for any direct, indirect,  
incidental, consequential, or  
other damage alleged in  
connection with the furnishing or  
use of this information.

NOTICE TO U.S.  
GOVERNMENT USERS:  
RESTRICTED RIGHTS  
COMMERCIAL COMPUTER  
SOFTWARE: "Use, duplication,  
or disclosure by the  
Government is subject to  
restrictions as set forth in  
subparagraph (c) (1)(ii) of the  
Rights in Technical Data Clause  
at DFARS 52.227-7013.

## Trademark Credits

CompuServe™ is a U.S.  
trademark of CompuServe, Inc.

MS-DOS® is a U.S. registered  
trademark of Microsoft  
Corporation.

Photoshop™ and PostScript®  
are registered trademarks of  
Adobe Systems Incorporated.

TrueType™ is a U.S. trademark  
of Apple Computer, Inc.

UNIX® is a registered trademark  
in the United States and other  
countries, licensed exclusively  
through X/Open Company  
Limited.

## Safety Information

WARNING  
Electrical Shock Hazard

To avoid electrical shock, use  
only supplied power cords and  
connect only to properly  
grounded (3-hole) wall outlets.

# Contents

## List of figures

## List of tables

## 1 Product information

Chapter contents . . . . .	17
Printer features . . . . .	19
Specifications . . . . .	21
Site requirements . . . . .	24
Media requirements . . . . .	26
Identification (model and serial numbers) . . . . .	34
Product overview . . . . .	35
Safety information . . . . .	39

## 2 Service approach

Chapter contents . . . . .	47
Introduction . . . . .	49
Parts and supplies . . . . .	49
Technical assistance . . . . .	52
Warranty . . . . .	55

## 3 Operational overview

Chapter contents . . . . .	57
Verifying package contents . . . . .	59
Verifying the cables are installed . . . . .	60
Connecting the printer to the network . . . . .	62
Changing the printer control panel overlay . . . . .	65
Printer control panel layout . . . . .	66
Menu maps . . . . .	68
Selecting the display language . . . . .	84
Installing the consumables . . . . .	85
Configuring input trays . . . . .	90
Verifying the printer is installed correctly . . . . .	92
Verifying DIMM installation . . . . .	93
Paper handling accessory status LEDs . . . . .	94

## 4 Printer maintenance

Chapter contents . . . . .	97
Cleaning procedures . . . . .	99
Printer consumables . . . . .	104
Installing consumables . . . . .	106

## 5 Theory of operation

Chapter contents . . . . .	119
Introduction . . . . .	123
Color theory . . . . .	126
Image formation . . . . .	129
Consumable detection mechanisms . . . . .	142
Electrical systems . . . . .	152
Mechanical systems . . . . .	157
Paper path . . . . .	166
EPH controller board . . . . .	180
2,000-sheet input unit . . . . .	180
Multi-bin mailbox . . . . .	186
Duplexer . . . . .	192
Printer timing . . . . .	192

## 6 Removal and replacement

Chapter contents . . . . .	199
Introduction . . . . .	203
Maintenance units . . . . .	205
Doors and covers . . . . .	206
Top assemblies . . . . .	223
Front assemblies . . . . .	227
Left assemblies . . . . .	229
Right assemblies . . . . .	237
Rear assemblies . . . . .	246
2,000-sheet input unit . . . . .	271
Multi-bin mailbox . . . . .	286

## 7 Troubleshooting

Chapter contents . . . . .	311
Pre-troubleshooting checklist . . . . .	315
Printer message troubleshooting . . . . .	316
Aids to troubleshooting . . . . .	361
Paper path troubleshooting . . . . .	378
Image formation troubleshooting . . . . .	383
Image defects troubleshooting . . . . .	386
Color balance adjustment . . . . .	414
Repetitive defects troubleshooting . . . . .	419
2,000-sheet input unit troubleshooting . . . . .	426
Multi-bin mailbox troubleshooting . . . . .	434
Communications troubleshooting . . . . .	439
Diagrams . . . . .	440

## 8 Parts and diagrams

Chapter contents . . . . .	443
Overview . . . . .	445
Ordering parts . . . . .	445
Illustrations and parts lists . . . . .	449
Numerical parts list . . . . .	502
Alphabetical parts list . . . . .	513

## Index





# List of figures

Figure 1.	Space requirements	25
Figure 2.	Example of printer model number and serial number label (110 V and 220 V)	34
Figure 3.	Front view	35
Figure 4.	Rear view	36
Figure 5.	Formatter assemblies	37
Figure 6.	Paper handling accessories and options	38
Figure 7.	Contents of printer box	59
Figure 8.	Power cord connection	60
Figure 9.	C-link and power cables connections	61
Figure 10.	Network connections	62
Figure 11.	Parallel cable connection	64
Figure 12.	Changing the printer control panel overlay	65
Figure 13.	Location of printer control panel features	66
Figure 14.	Consumable installation order	85
Figure 15.	DIMM slot configuration	93
Figure 16.	Paper handling accessory status LEDs	94
Figure 17.	Cleaning the post charger unit	99
Figure 18.	Cleaning the density sensor	100
Figure 19.	Cleaning the transfer charger	101
Figure 20.	Removing the waste toner tray cover	102
Figure 21.	Cleaning the waste toner tray	103
Figure 22.	Location of consumables in printer	104
Figure 23.	Contents of transfer kit	106
Figure 24.	Contents of drum kit	110
Figure 25.	Contents of fuser kit	113
Figure 26.	Cross-section view of internal components	124
Figure 27.	Image formation	129
Figure 28.	Electrostatic latent image formation block	130
Figure 29.	Preconditioning exposure	131
Figure 30.	Primary charging of imaging drum	132
Figure 31.	Black toner cartridge (left) and color toner cartridge (right) development	133
Figure 32.	Primary transfer	134
Figure 33.	Post charging	135
Figure 34.	Secondary transfer	136
Figure 35.	Separation	137
Figure 36.	Cleaning roller charging	138

Figure 37.	Transfer drum cleaning . . . . .	139
Figure 38.	Imaging drum cleaning block . . . . .	140
Figure 39.	Fusing the toner . . . . .	141
Figure 40.	Waste toner level detection . . . . .	143
Figure 41.	Color toner level detections . . . . .	145
Figure 42.	Color toner lever detection . . . . .	146
Figure 43.	Density sensor . . . . .	148
Figure 44.	Transfer belt control . . . . .	149
Figure 45.	Cleaning roller control . . . . .	150
Figure 46.	Carousel control . . . . .	151
Figure 47.	Power distribution circuit diagram . . . . .	152
Figure 48.	Power Save circuit diagram . . . . .	153
Figure 49.	High-voltage power supply circuit . . . . .	156
Figure 50.	Laser/scanner . . . . .	158
Figure 51.	Printer motors and heaters . . . . .	159
Figure 52.	Carousel motor (M1) . . . . .	160
Figure 53.	Drum motor (M2) . . . . .	161
Figure 54.	Cartridge motor (M3) . . . . .	162
Figure 55.	Main motor (M4) . . . . .	163
Figure 56.	Pick-up motor (M5) . . . . .	164
Figure 57.	Paper path . . . . .	166
Figure 58.	Tray 2 and 3 pick-up . . . . .	169
Figure 59.	Tray 1 pick-up . . . . .	171
Figure 60.	Printer sensors . . . . .	172
Figure 61.	Printer switches . . . . .	174
Figure 62.	Printer clutches and solenoids . . . . .	177
Figure 63.	Fusing and delivery unit . . . . .	179
Figure 64.	2,000-sheet input unit sensors, switches, clutches, and motors . . . . .	181
Figure 65.	2,000-sheet input unit paper path . . . . .	185
Figure 66.	Multi-bin mailbox cabling . . . . .	188
Figure 67.	Multi-bin mailbox sensors . . . . .	189
Figure 68.	Multi-bin mailbox paper path . . . . .	191
Figure 69.	Timing chart for WAIT period (1 of 2) . . . . .	193
Figure 70.	Timing chart for WAIT period (2 of 2) . . . . .	194
Figure 71.	Timing chart for printing full color letter-sized page (1 of 2) . . . . .	195
Figure 72.	Timing chart for printing full color letter-sized page (2 of 2) . . . . .	196
Figure 73.	Timing chart for printing full color 11-by-17-inch sized page (1 of 2) . . . . .	197
Figure 74.	Timing chart for printing full color 11-by-17 inch sized page (2 of 2) . . . . .	198

Figure 75.	Orientation of printer and accessories: top, front, and right . . . . .	206
Figure 76.	Orientation of printer and accessories: rear and left . . . . .	207
Figure 77.	Removing the front cover . . . . .	208
Figure 78.	Front right cover . . . . .	209
Figure 79.	Inside left panel . . . . .	210
Figure 80.	Screws behind left door . . . . .	211
Figure 81.	Screws behind right door . . . . .	212
Figure 82.	Connector on top cover . . . . .	212
Figure 83.	Left door and strap . . . . .	213
Figure 84.	Screws on left rear cover . . . . .	214
Figure 85.	Screws on upper left door . . . . .	215
Figure 86.	Stopper hinges on lower left cover . . . . .	216
Figure 87.	Connectors on the right upper door . . . . .	217
Figure 88.	E-ring . . . . .	218
Figure 89.	Spring on right cover subassembly . . . . .	219
Figure 90.	Right rear cover . . . . .	220
Figure 91.	Screws on the right lower cover . . . . .	221
Figure 92.	Rear cover . . . . .	222
Figure 93.	Bottom of the control panel . . . . .	223
Figure 94.	Scanner unit . . . . .	224
Figure 95.	Upper airflow vent . . . . .	225
Figure 96.	Face-down exit sensor rail . . . . .	225
Figure 97.	Face-down output assembly . . . . .	226
Figure 98.	Toner lock sensor and color cartridge sensor . . . . .	227
Figure 99.	Subrelay PCA . . . . .	228
Figure 100.	Formatter board . . . . .	230
Figure 101.	Connector on formatter board . . . . .	232
Figure 102.	Back side of formatter board . . . . .	232
Figure 103.	Feeder assembly . . . . .	233
Figure 104.	Face-up solenoid . . . . .	234
Figure 105.	Face-up solenoid . . . . .	235
Figure 106.	Screws on the face-up exit assembly . . . . .	236
Figure 107.	Tray 1 . . . . .	237
Figure 108.	Pick-up roller . . . . .	238
Figure 109.	Registration roller assembly (front) . . . . .	239
Figure 110.	Registration roller assembly (back) . . . . .	240
Figure 111.	Connectors on registration roller assembly . . . . .	241
Figure 112.	Density sensor . . . . .	242
Figure 113.	Paper pick-up assembly . . . . .	243
Figure 114.	Paper pick-up assembly . . . . .	244
Figure 115.	Paper pick-up assembly . . . . .	245

Figure 116.	Rear of printer with cover removed . . . . .	246
Figure 117.	Rear of printer with formatter pan removed . . . . .	247
Figure 118.	Formatter pan . . . . .	248
Figure 119.	Formatter pan (left side) . . . . .	249
Figure 120.	Fan 1 . . . . .	250
Figure 121.	Fan 2 . . . . .	251
Figure 122.	Power supply . . . . .	252
Figure 123.	Controller board . . . . .	253
Figure 124.	Cartridge motor . . . . .	254
Figure 125.	Main motor . . . . .	255
Figure 126.	Carousel motor PCA . . . . .	256
Figure 127.	Fans 1 and 2 housing assemblies . . . . .	257
Figure 128.	Carousel motor . . . . .	258
Figure 129.	Lower air duct . . . . .	259
Figure 130.	Screws on the delivery drive assembly . . . . .	260
Figure 131.	Access to main gear assembly . . . . .	261
Figure 132.	High-voltage converter 1 PCA . . . . .	262
Figure 133.	High-voltage converter 1 . . . . .	263
Figure 134.	High-voltage converter 2 PCA . . . . .	264
Figure 135.	High-voltage converter 2 . . . . .	265
Figure 136.	High-voltage converter 2 . . . . .	266
Figure 137.	Drum/cartridge drive assembly . . . . .	267
Figure 138.	Separation discharge high-voltage converter . . . . .	268
Figure 139.	Plate over media size sensing PCAs . . . . .	269
Figure 140.	Media size sensing PCAs . . . . .	270
Figure 141.	Front cover of the 2,000-sheet input unit . . . . .	272
Figure 142.	Back cover removal . . . . .	273
Figure 143.	Left cover removal . . . . .	274
Figure 144.	Vertical transfer unit (VTU) . . . . .	275
Figure 145.	Right cover with VTU removed . . . . .	276
Figure 146.	Tray 4 removal . . . . .	277
Figure 147.	Paper pick-up assembly . . . . .	278
Figure 148.	Controller PCA . . . . .	279
Figure 149.	Screw on front LED PCA assembly . . . . .	280
Figure 150.	Front LED PCA . . . . .	281
Figure 151.	Power supply . . . . .	281
Figure 152.	Main drive assembly . . . . .	282
Figure 153.	Paper quantity switch assembly . . . . .	283
Figure 154.	Paper size switch assembly . . . . .	284
Figure 155.	Tension springs . . . . .	285
Figure 156.	Front and back covers . . . . .	287
Figure 157.	Top cover . . . . .	288
Figure 158.	Power supply . . . . .	289
Figure 159.	Paper bins . . . . .	290

Figure 160.	Flipper assembly (1 of 3)	291
Figure 161.	Flipper assembly (2 of 3)	292
Figure 162.	Flipper assembly (3 of 3)	292
Figure 163.	Delivery head motor	293
Figure 164.	Transport belt motor	294
Figure 165.	Input paper guide (1 of 2)	295
Figure 166.	Input paper guide (2 of 2)	296
Figure 167.	Metallic tape and housing assembly (1 of 2)	297
Figure 168.	Metallic tape and housing assembly (2 of 2)	298
Figure 169.	Controller PCA (1 of 2)	299
Figure 170.	Controller PCA (2 of 2)	300
Figure 171.	Anti-curl strings (1 of 2)	301
Figure 172.	Anti-curl strings (2 of 2)	302
Figure 173.	Delivery head assembly (1 of 4)	303
Figure 174.	Delivery head assembly (2 of 4)	304
Figure 175.	Delivery head assembly (3 of 4)	304
Figure 176.	Delivery head assembly (4 of 4)	305
Figure 177.	Interlock switch	306
Figure 178.	Diagnostic LED PCA	307
Figure 179.	User status LED PCA	308
Figure 180.	Attachment assembly	309
Figure 181.	Example of a configuration page	362
Figure 182.	Right upper cover detection interlock	370
Figure 183.	Drum cartridge detection interlock	370
Figure 184.	Black toner cartridge detection interlock	371
Figure 185.	Toner carousel door detection interlock	371
Figure 186.	Front cover/delivery cover detection interlocks	372
Figure 187.	Laser shutters	373
Figure 188.	Left upper cover detection	374
Figure 189.	Right lower cover detection	374
Figure 190.	Printer paper path	380
Figure 191.	Image orientation and direction of travel	386
Figure 192.	Incorrect registration (late and early print)	388
Figure 193.	Image skew	389
Figure 194.	Blank or partially blank page	390
Figure 195.	Horizontal lines (in one color)	391
Figure 196.	Horizontal lines (in all colors, CMYK)	392
Figure 197.	Rain or speckled print	393
Figure 198.	Black, brown, or orange bands	394
Figure 199.	Background toner scatter	395
Figure 200.	Mottled process colors or poor transfer	396
Figure 201.	Stray toner	397
Figure 202.	Dark yellow or contaminated print	398
Figure 203.	Color adjust page	415

Figure 204.	Repetitive defect ruler	420
Figure 205.	Cleaning the transfer drum	423
Figure 206.	Rear view of 2,000-sheet input unit	428
Figure 207.	Location of sensors in the 2,000-sheet input unit	432
Figure 208.	Multi-bin mailbox power supply test mode switch	434
Figure 209.	Connectors on the controller board	440
Figure 210.	General printer circuit diagram (1 of 2)	441
Figure 211.	General printer circuit diagram (2 of 2)	442
Figure 212.	Major assembly locations (1 of 2)	450
Figure 213.	Major assembly locations (2 of 2)	451
Figure 214.	Printer covers and doors (1 of 3)	452
Figure 215.	Printer covers and doors (2 of 3)	454
Figure 216.	Printer covers and doors (3 of 3)	456
Figure 217.	Internal cover assembly	458
Figure 218.	Internal components (1 of 6)	460
Figure 219.	Internal components (2 of 6)	462
Figure 220.	Internal components (3 of 6)	464
Figure 221.	Internal components (4 of 6)	466
Figure 222.	Internal components (5 of 6)	468
Figure 223.	Internal components (6 of 6)	470
Figure 224.	Drum/cartridge drive assembly	472
Figure 225.	Delivery drive assembly	473
Figure 226.	Tray 3 assembly	474
Figure 227.	Tray 2 assembly	475
Figure 228.	Paper pick-up assembly (1 of 3)	476
Figure 229.	Paper pick-up assembly (2 of 3)	477
Figure 230.	Paper pick-up assembly (3 of 3)	478
Figure 231.	Registration frame assembly	480
Figure 232.	Registration roller assembly	481
Figure 233.	Feeder assembly	482
Figure 234.	Tray 1 pick-up assembly	483
Figure 235.	Tray 1 assembly	484
Figure 236.	Delivery assembly	485
Figure 237.	Delivery cover assembly	486
Figure 238.	Transfer belt assembly	487
Figure 239.	Fuser assembly (1 of 2)	488
Figure 240.	Fuser assembly (2 of 2)	489
Figure 241.	PCA assembly location diagram	491
Figure 242.	2,000-sheet input unit covers and doors	492
Figure 243.	2,000-sheet input unit internal components	494
Figure 244.	Multi-bin mailbox components (1 of 3)	496
Figure 245.	Multi-bin mailbox components (2 of 3)	498
Figure 246.	Multi-bin mailbox components (3 of 3)	500

# List of tables

Table 1.	Features and optional accessories by printer model.	19
Table 2.	Printer performance	20
Table 3.	Electrical specifications	21
Table 4.	Operating environment specifications	21
Table 5.	Acoustic emissions	22
Table 6.	Printer dimensions	22
Table 7.	Consumable storage specifications	23
Table 8.	Media capacity and sizes for input trays	28
Table 9.	Media capacity and sizes for the multi-bin mailbox	30
Table 10.	Ordering information	49
Table 11.	Technical support websites	50
Table 12.	Printer control panel menu map overview	69
Table 13.	Information Menu	71
Table 14.	Proof and Print Menu	72
Table 15.	Paper Handling Menu	72
Table 16.	Configuration Menu	75
Table 17.	Printing Menu	76
Table 18.	I/O Menu	78
Table 19.	Resets Menu	78
Table 20.	Color Adjust Menu	79
Table 21.	Service Mode Menu	80
Table 22.	Paper handling accessory status LEDs	95
Table 23.	Replacement frequencies for printer consumables	105
Table 24.	Subtractive color absorption	126
Table 25.	Subtractive color mixing	127
Table 26.	Additive color mixing	128
Table 27.	Fusing temperatures	154
Table 28.	Printer motor and heater names and descriptions	159
Table 29.	Fan operation	165
Table 30.	Feed speeds based on media type	167
Table 31.	Printer sensor names and descriptions	173
Table 32.	Printer switch names and descriptions	175
Table 33.	Tray 2 and Tray 3 paper size detection	176
Table 34.	Printer clutch and solenoid names and descriptions	177
Table 35.	2,000-sheet input unit sensors, switches, clutches, and motors	182
Table 36.	Paper quantity detection switches	183
Table 37.	Paper size detection switches	183

Table 38.	Multi-bin mailbox sensors, switches, motors, and controller board PCA . . . . .	190
Table 39.	Numbered printer messages . . . . .	316
Table 40.	Unnumbered printer messages . . . . .	334
Table 41.	Sensor monitor test . . . . .	369
Table 42.	Media jam detection . . . . .	381
Table 43.	Streaking . . . . .	401
Table 44.	Neutral axis adjustments . . . . .	418
Table 45.	Status LED on the 2,000-sheet input unit . . . . .	427
Table 46.	Patterns of LED flashing (2-second pause between each pattern) . . . . .	429
Table 47.	DIP switch settings for troubleshooting test procedures . . . . .	430
Table 48.	Status LEDs on the multi-bin mailbox . . . . .	436
Table 49.	Options, accessories, and consumables . . . . .	446
Table 50.	Miscellaneous parts . . . . .	448
Table 51.	Printer doors and covers (1 of 3) . . . . .	453
Table 52.	Printer doors and covers (2 of 3) . . . . .	455
Table 53.	Printer covers and doors parts . . . . .	457
Table 54.	Internal cover assembly parts . . . . .	459
Table 55.	Internal components parts (1 of 6) . . . . .	461
Table 56.	Internal components parts (2 of 6) . . . . .	463
Table 57.	Internal components parts (3 of 6) . . . . .	465
Table 58.	Internal components parts (4 of 6) . . . . .	467
Table 59.	Internal components parts (5 of 6) . . . . .	469
Table 60.	Internal components parts (6 of 6) . . . . .	471
Table 61.	Drum/cartridge drive assembly parts . . . . .	472
Table 62.	Delivery drive assembly parts . . . . .	473
Table 63.	Tray 3 assembly parts . . . . .	474
Table 64.	Tray 2 assembly . . . . .	475
Table 65.	Paper pick-up assembly parts . . . . .	479
Table 66.	Registration frame assembly parts . . . . .	480
Table 67.	Registration roller assembly parts . . . . .	481
Table 68.	Feeder assembly parts . . . . .	482
Table 69.	Tray 1 pick-up assembly parts . . . . .	483
Table 70.	Tray 1 assembly parts . . . . .	484
Table 71.	Delivery assembly parts . . . . .	485
Table 72.	Delivery cover assembly parts . . . . .	486
Table 73.	Transfer belt assembly parts . . . . .	487
Table 74.	Fuser assembly parts . . . . .	490
Table 75.	PCA assembly parts . . . . .	491
Table 76.	2,000-sheet input unit cover and door parts . . . . .	493
Table 77.	2,000-sheet input unit internal component parts . . . . .	495
Table 78.	Multi-bin mailbox component parts (1 of 3) . . . . .	497



Table 79. Multi-bin mailbox component parts (2 of 3) . . . . .	499
Table 80. Multi-bin mailbox component parts (3 of 3) . . . . .	501
Table 81. Numerical parts list . . . . .	502
Table 82. Alphabetical parts list . . . . .	513



# 1 Product information

## Chapter contents

Printer features . . . . .	19
Specifications . . . . .	21
Electrical specifications . . . . .	21
Operating environment specifications . . . . .	21
Acoustic emission specifications . . . . .	22
Printer dimensions . . . . .	22
Consumable storage specifications . . . . .	23
Site requirements . . . . .	24
General guidelines . . . . .	24
Space requirements . . . . .	25
Media requirements . . . . .	26
Selecting media . . . . .	26
Storing media . . . . .	27
Media capacity and sizes for input trays . . . . .	28
Media capacity and sizes for the multi-bin mailbox . . . . .	30
Media weights and sizes for duplexer . . . . .	31
Envelopes . . . . .	31
Transparencies . . . . .	31
Glossy media . . . . .	32
Heavy paper stock . . . . .	32
Colored media . . . . .	32
Media to avoid . . . . .	33

Identification (model and serial numbers) . . . . .	34
Product overview . . . . .	35
External views . . . . .	35
Formatter assemblies . . . . .	37
Paper handling accessories and options . . . . .	38
Safety information . . . . .	39
FCC regulations . . . . .	39
Canadian DOC regulations . . . . .	39
Declarations of conformity . . . . .	40
VCCI statement (Japan) . . . . .	43
EMI statement (Korea) . . . . .	43
Laser safety statement . . . . .	43
Laser statement for Finland . . . . .	44
Product information sheet . . . . .	45
Toner safety . . . . .	45
Material Safety Data Sheet . . . . .	45
Ozone safety . . . . .	46

## Printer features

**Table 1. Features and optional accessories by printer model**

	8500	8500 N	8500 DN
<b>Features</b>			
Standard DIMM memory	32 MB	32 MB	64 MB
Expandable to 512 MB of DIMM <sup>1</sup> memory	X	X	X
Internal printer hard disk			X
2,000-sheet input unit			X
Duplexer			X
HP JetDirect 600N internal print server		X	X
<b>Optional accessories</b>			
External (EIO-compatible) printer hard disk	X	X	
ROM, or synchronous DRAM DIMMs	X	X	X
Duplexer	X	X	
HP JetDirect 600N internal print server	X		
Multi-bin mailbox			X
<sup>1</sup> To expand the DIMM memory to 512 MB, install 64-MB DIMMs in all eight DIMM slots.			

**Table 2. Printer performance**

<b>Print speeds</b>	<ul style="list-style-type: none"><li>● 24 pages per minute (ppm) black and white (b/w)</li><li>● 6 ppm color</li></ul>
<b>Text and graphics resolution</b>	<ul style="list-style-type: none"><li>● 600 dpi resolution</li></ul>
<b>Approximate print speeds</b>	
Letter, A4-size	<ul style="list-style-type: none"><li>● 24 ppm b/w; 6 ppm color</li></ul>
Legal, Executive, 11-by-17 inch size	<ul style="list-style-type: none"><li>● 12 ppm b/w; 3 ppm color</li></ul>
Heavy paper	<ul style="list-style-type: none"><li>● 3.2 ppm b/w; 2.2 ppm color</li></ul>
Transparencies	<ul style="list-style-type: none"><li>● 2.6 ppm b/w; 2.0 ppm color</li></ul>
<b>Fonts</b>	<ul style="list-style-type: none"><li>● HP LaserJet 45 TrueType™ font set</li><li>● PostScript® fonts</li></ul>
<b>Printer personality support</b>	<ul style="list-style-type: none"><li>● Automatic personality switching</li><li>● PCL<sup>1</sup> and PostScript support</li></ul>
<b>User interface and EIO</b>	<ul style="list-style-type: none"><li>● Standard ECP or bidirectional parallel cable interface (IEEE-1284 compliant)</li><li>● 2 enhanced input/output (EIO) slots</li><li>● Automatic I/O switching</li></ul>
<sup>1</sup> Not available at initial product introduction.	

The approximate print speeds offered by this printer might vary from those listed above because the following factors affect processing time:

- complexity and size of graphics
- I/O configuration
- computer configuration
- amount of printer memory
- network operating system
- network configuration
- printer color calibration

# Specifications

## Electrical specifications

**Table 3. Electrical specifications**

Item	110-volt models	220-volt models
Power requirements	100 to 127 V (+/- 10%) 50/60 Hz (+/- 2 Hz)	220 to 240 V (+/- 10%) 50/60 Hz (+/- 2 Hz)
Power consumption (typical)		
During printing (black and white)	750 W (average)	750 W (average)
During printing (color)	375 W (average)	375 W (average)
During standby	190 W (average)	190 W (average)
During Power Save mode	< 45 W	< 45 W
During Off mode	< 2 W	< 2 W
Minimum recommended circuit capacity for typical product	12.0 A at 120 V	6.0 A at 220 V

## Operating environment specifications

**Table 4. Operating environment specifications**

Item	Operating	Storage
Temperature Recommended Allowed	20 to 26° C (68 to 79° F) 15 to 30° C (59 to 86° F)	0 to 35° C (32 to 95° F) -20 to 60° C (-4 to 140° F)
Humidity Recommended Allowed	20 to 50% RH 10 to 80% RH	35 to 85% RH 10 to 95% RH
Altitude Allowed	0 to 3,048 m (0 to 10,000 ft)	0 to 3,048 m (0 to 10,000 ft)

## Acoustic emission specifications

**Table 5. Acoustic emissions**

<b>Operation position (per ISO 9296, DIN 45635, T.19)</b>	
Printing	L <sub>p</sub> A 54 dB(A)
Standby	L <sub>p</sub> A 49 dB(A)
<b>Bystander 1 meter (per ISO 7779, DIN 45635, T.19)</b>	
Printing	L <sub>p</sub> A 50 dB(A)
Standby	L <sub>p</sub> A 45 dB(A)
<b>Sound power (per ISO 9296)</b>	
Printing	6.7 B (A)
Standby	6.1 B (A)

## Printer dimensions

**Table 6. Printer dimensions**

	<b>Printer</b>	<b>Printer with stand</b>	<b>Printer with 2,000-sheet input unit and multi-bin mailbox</b>
<b>Height</b>	750 mm 30 in	1111 mm 44 in	1230 mm 48 in
<b>Width</b>	566 mm 22 in	566 mm 22 in	1056 mm 42 in
<b>Depth</b>	625 mm 25 in	625 mm 25 in	625 mm 25 in
<b>Weight (with consumables)</b>	87 kg 192 lb	100 kg 220 lb	118 kg 260 lb



## Consumable storage specifications

The life of consumables is greatly affected by their storage environment. Use the following table to determine shelf life of stored consumables.

For consumable replacement specifications, see page 105.

**Table 7. Consumable storage specifications**

<b>Temperature</b>	Normal (maximum of 2.5 years)	0 to 35° C (32 to 95° F)
	Severe (maximum of 18 days)	High 35 to 40° C (95 to 104° F) Low 0 to -20° C (32 to -4° F)
<b>Maximum temperature change rate</b>	40 to 15° C (104 to 59° F) within 3 minutes -20 to 25° C (-4 to 77° F) within 3 minutes	
<b>Humidity</b>	Normal (maximum of 2.5 years)	35 to 85% RH
	Severe (maximum of 18 days)	High 85 to 95% RH Low 10 to 35% RH
<b>Atmospheric pressure</b>	460 to 760 mm Hg	

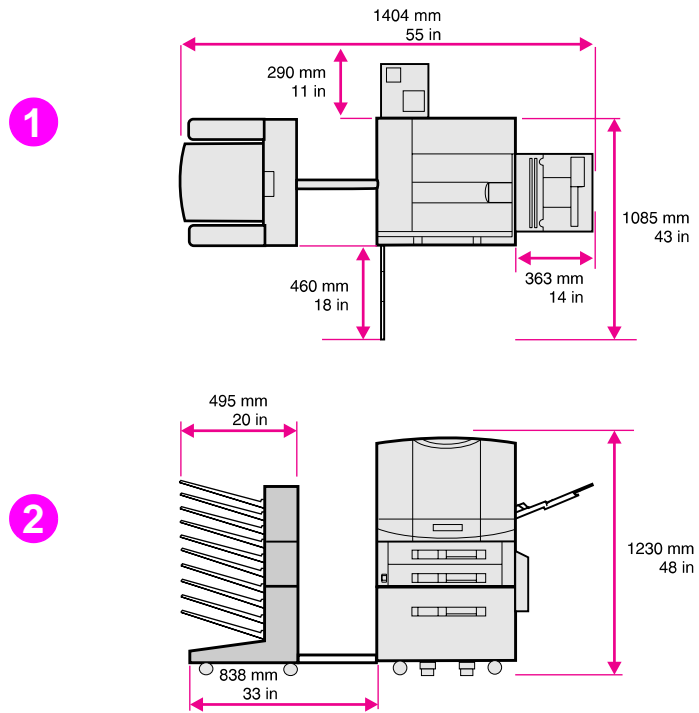
## Site requirements

### General guidelines

Locating and placing the printer correctly are important in maintaining the performance level that has been set at the factory. In particular, be sure to adhere to the environmental specifications listed in this chapter. The following are recommendations for locating and placing the printer:

- Install in a well-ventilated, dust-free area.
- Install on a hard, level surface.
- Install where the temperature and humidity do not change abruptly. Do not install near water sources, humidifiers, air conditioners, refrigerators, or other major appliances.
- Do not expose the printer to direct sunlight, dust, open flames, or ammonia fumes.
- Install the printer away from walls or other objects. There must be enough space around the printer for proper access and ventilation (see figure 1 on page 25).
- Install the printer away from the direct flow of exhaust from air ventilation systems.

## Space requirements



**Figure 1.** Space requirements

- 1 Top view (with optional multi-bin mailbox and 2,000-sheet input unit)
- 2 Front view (with optional multi-bin mailbox and 2,000-sheet input unit)

## Media requirements

### Selecting media

Many types of paper and other print media can be used with the printer, within certain specifications. Using media that does not meet the specifications outlined in this chapter can increase the incidence of media jams, contribute to repair and maintenance costs, and cause premature wear, print quality problems, and problems requiring service. This service might not be covered by the HP warranty or service agreements.

Before purchasing media or specialized forms, test a small quantity in the printer. Make sure your media supplier obtains and understands the media specifications in the *HP LaserJet Printer Family Paper Specification Guide*. For ordering information, see page 445.

---

**Note**

It is possible that media could meet all of the specifications in this chapter and still not print satisfactorily. This might be caused by abnormal characteristics of the printing environment, such as extremes in temperature and humidity.

---

- For complete media specifications, see the *HP LaserJet Printer Family Paper Specification Guide*.
- Use only print media that meet the specifications outlined in this chapter.
- Do not try to print unsupported sizes or weights of media or other unsupported media.
- Always handle transparencies and glossy media by their edges to avoid fingerprints in the image area.
- Adhesives on any type of media must be compatible with the printer's fusing temperatures (approximately 190° C or 374° F).
- Do not use media that have already passed through the printer or through a copy machine, even if there is no printing on the page.
- Recycled media can be used with this printer. Recycled media must meet the specifications described in this chapter.

## Storing media

Follow these guidelines when stacking and storing media:

- Store paper in its ream wrapper until you are ready to use it.
- Rewrap partially used packages of media before storing.
- Stack each carton upright and squarely on top of each other.
- Store envelopes in a protective box to avoid damaging the envelope edges.
- Keep stored media away from temperature and humidity extremes.
- *Do not* store cartons or reams directly on the floor where they will absorb humidity. Instead, place cartons on a pallet or on shelves.
- *Do not* store individual reams in any manner that causes them to curl or warp along the edges.
- *Do not* stack more than six cartons on top of each other.
- *Do not* place anything on top of media, regardless of whether the media is packaged or unpackaged.
- *Do not* store printed documents in vinyl folders or expose the documents to petroleum-based solvents.

## Media capacity and sizes for input trays

The following table lists the types and sizes of media supported by each input tray. For best results, use HP LaserJet paper or conventional white copier paper. The media should be of good quality and free of cuts, nicks, tears, spots, loose particles, dust, wrinkles, voids, perforations, and curled or bent edges. For a complete list of media specifications, see the *HP LaserJet Printer Family Paper Specification Guide*.

**Table 8. Media capacity and sizes for input trays**

Media type	Media size and orientation	Media weight	Maximum capacity
<b>Tray 1</b>			
Paper Plain Preprinted Letterhead Prepunched Bond Recycled Color Card stock Heavy (more than 28 lb, 105 g/m <sup>2</sup> ) Glossy	11 by 17 in (portrait) JIS B4 (portrait) A3 (portrait) A4 (portrait) A5 (portrait) Custom min. (99 by 190 mm, 3.90 by 7.49 in) (portrait) Custom max. (304 by 469 mm, 11.98 by 18.48 in) (portrait) Executive (portrait) ISO B5 (portrait) JIS B4 (portrait) JIS B5 (portrait) Letter (landscape) Legal (landscape)	16 to 58 lb (60 to 216 g/m <sup>2</sup> ) bond	100 sheets of 20 lb (75 g/m <sup>2</sup> ) bond  Limit to media-fill mark on the media width guides
Envelopes	B5 (portrait) C5 (portrait) Commercial #10 (Com10) (portrait) DL (portrait) Double Post Card (JPOSTD) Monarch (portrait)	Maximum 24 lb (90 g/m <sup>2</sup> ) bond	Approximately 10  Limit to media-fill mark on the media width guides
Labels	A4 (landscape) Letter (landscape)	—	Limit to media-fill mark on the media width guides
Transparencies	A4 (landscape) Letter (landscape)	4 to 5 mils (0.10 to 0.13 mm) thick*	Limit to media-fill mark on the media width guides

**Table 8. Media capacity and sizes for input trays (continued)**

Media type	Media size and orientation	Media weight	Maximum capacity
<b>Tray 2</b>			
Paper Plain Preprinted Letterhead Prepunched Bond Recycled Color Glossy	A4 (landscape) JIS B4 (portrait) Letter (landscape) Legal (portrait)	16 to 28 lb (60 to 105 g/m <sup>2</sup> ) bond	500 sheets of 20 lb (75 g/m <sup>2</sup> ) bond  Limit to media-fill mark on the media width guides
Transparency	A4 (portrait) Letter (portrait)	4 to 5 mils (0.10 to 0.13 mm) thick*	Limit to media-fill mark on the media width guides
<b>Tray 3</b>			
Paper Plain Preprinted Letterhead Prepunched Bond Recycled Color Glossy	11 by 17 in (portrait) A3 (portrait) A4 (landscape) JIS B4 (portrait) Legal (portrait) Letter (landscape)	16 to 28 lb (60 to 105 g/m <sup>2</sup> ) bond	500 sheets of 20 lb (75 g/m <sup>2</sup> ) bond  Limit to media-fill mark on the media width guides
Transparency	A4 (portrait) Letter (portrait)	4 to 5 mils (0.10 to 0.13 mm) thick*	Limit to media-fill mark on the media width guides
<b>2,000-sheet input unit (only available on 8500 DN model)</b>			
Paper Plain Preprinted Letterhead Prepunched Bond Recycled Color Glossy	11 by 17 in (portrait) A4 (landscape) JIS B4 (portrait) Legal (portrait) Letter (landscape)	16 to 28 lb (60 to 105 g/m <sup>2</sup> ) bond	2,000 sheets of 20 lb (75 g/m <sup>2</sup> ) bond  Limit to media-fill mark on the media width guides
* HP recommends using transparencies that are 5 mil (0.13 mm) thick with this printer.			

## Media capacity and sizes for the multi-bin mailbox

The following table lists the types and sizes of media supported by multi-bin mailbox output bins.

**Table 9. Media capacity and sizes for the multi-bin mailbox**

Media type	Media size	Media weight	Maximum capacity
<b>Mailboxes</b>			
Paper Plain Preprinted Letterhead Prepunched Bond Recycled Color	11 by 17 in 3 A4 JIS B4 Legal Letter	16 to 28 lb (60 to 105 g/m <sup>2</sup> ) bond	250 sheets of 20 lb (75 g/m <sup>2</sup> ) bond
<b>Left (face-up) output bin</b>			
Paper Plain Preprinted Letterhead Prepunched Bond Recycled Color Card Stock Heavy (more than 28 lb, 105 g/m <sup>2</sup> ) Glossy	11 by 17 in A3 A4 A5 Custom min. (99 by 190 mm, 3.90 by 7.49 in) Custom max. (304 by 469 mm, 11.98 by 18.48 in) Executive JIS B4 JIS B5 Legal Letter	16 to 58 lb (60 to 216 g/m <sup>2</sup> ) bond	125 sheets of 20 lb (75 g/m <sup>2</sup> ) bond
Labels	A4 Letter	—	—
Transparency	A4 Letter	4 to 5 mils (0.10 to 0.13 mm) thick*	—
Envelopes	B5 C5 Commercial #10 (Com10) DL Double Post Card (JPOSTD) Monarch	Maximum 24 lb (90 g/m <sup>2</sup> ) bond	30 Monarch-sized envelopes
* HP recommends using transparencies that are 5 mils (0.13 mm) thick with this printer.			



## Media weights and sizes for duplexer

The duplexer accepts media up to 28 lb (105 g/m<sup>2</sup>) bond and as large as A3 size.

### Envelopes

- The **Envelope** media type setting in the printer driver has been optimized for the best print adhesion for most envelopes.
- The **Heavy Paper** mode might also work well for some envelopes, especially if the printing environment humidity is low.
- Output envelopes to the left (face-up) output bin to reduce curl.

---

#### CAUTION

To prevent severe printer damage, envelopes with a peel-off adhesive strip or with more than one flap must use adhesives compatible with the printer's fusing temperatures (approximately 190° C or 374° F). Extra flaps or strips can result in wrinkling or creasing, and can cause jamming.

### Transparencies

- The printer's internal color settings are optimized for the best color quality if **Transparency** is selected as the media type in the printer driver. Using other media type settings will result in less accurate colors.

---

#### CAUTION

Use only transparencies supported for use in this printer. Using transparencies that do not meet the specifications for this printer can cause poor print quality, media jams, and printer damage not covered under warranty.

- Although this printer supports transparencies between 4 and 5 mils (0.10 to 0.13 mm) thick, HP recommends using transparencies that are 5 mil (0.13 mm) thick.
- To prevent damage to the printer, transparencies must be able to withstand the printer's fusing temperature (approximately 190° C or 374° F).
- Handle transparencies by the edges. Oil from your fingers can be deposited on the transparencies, causing print quality problems. Also, allow transparencies to cool before handling to prevent curling.

---

#### WARNING!

Allow transparencies to cool before handling to prevent burns.

## Glossy media

If you want the effect of glossy media, use only HP LaserJet glossy media in this printer. For ordering information, see page 445.

## Heavy paper stock

Heavy paper stock is any paper heavier than 28 lb up to 58 lb (105 to 216 g/m<sup>2</sup>) bond. Always print heavy paper stock from tray 1. In the printer driver, select **Heavy Paper** or **Cardstock** as the paper type on the paper tab to ensure the correct finish on the media. Also, use the left (face-up) output bin to prevent media jams. For more information on changing the printer driver settings, see the online help.

Do *not* use extremely heavy paper stock (greater than 58 lb, or 216 g/m<sup>2</sup> bond). Misfeeds, mis-stacking, media jams, poor toner fusing, poor print quality, and excessive mechanical wear can result.

## Colored media

Colored media should be of the same high quality as white xerographic paper. Pigments used must be able to withstand the printer's fusing temperature (approximately 190° C or 374° F). Do not use media with a colored coating that was added after the media was produced.

The printer cannot detect the color of media you are using. Varying the shade or color of the media can change the shades of the printed colors.

## Media to avoid

To avoid poor print quality or damage to the printer, do not use any of the following:

- media that is coated or embossed
- media with cutouts or perforations (except prepunched paper)
- multi-part forms
- media with irregularities, such as tabs or staples
- preprinted media that contains thermography or inks that melt, vaporize, or release hazardous emissions when subjected to the fusing temperature (approximately 190° C or 374° F)
- media that produces hazardous emissions, melts, offsets, or discolors when heated to the printer's fusing temperature (approximately 190° C or 374° F)
- media that has already been through a photocopier or laser printer, even if there is no printing on the page
- media with a watermark if solid fill areas are to be printed
- transparencies designed for ink jet printers

## Identification (model and serial numbers)

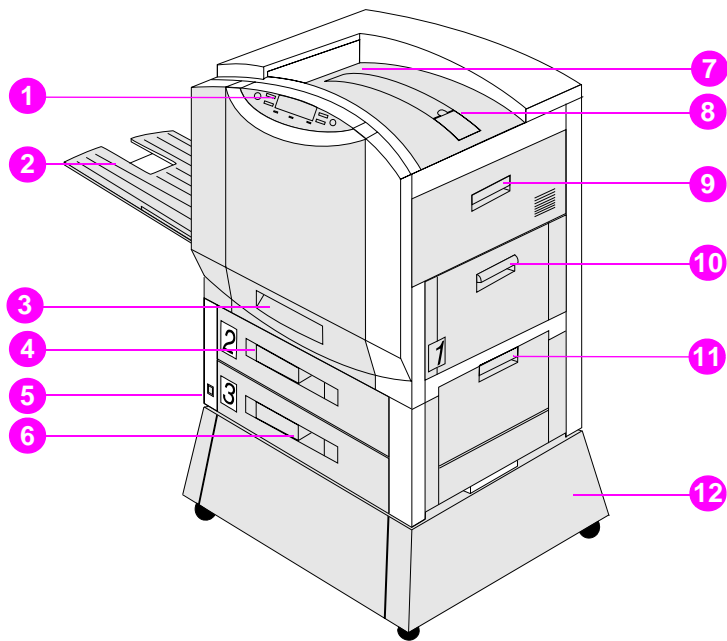
To identify the model number and serial number, find the label located on the rear of the printer similar to the one shown in figure 2.



**Figure 2.** Example of printer model number and serial number label (110 V and 220 V)

## Product overview

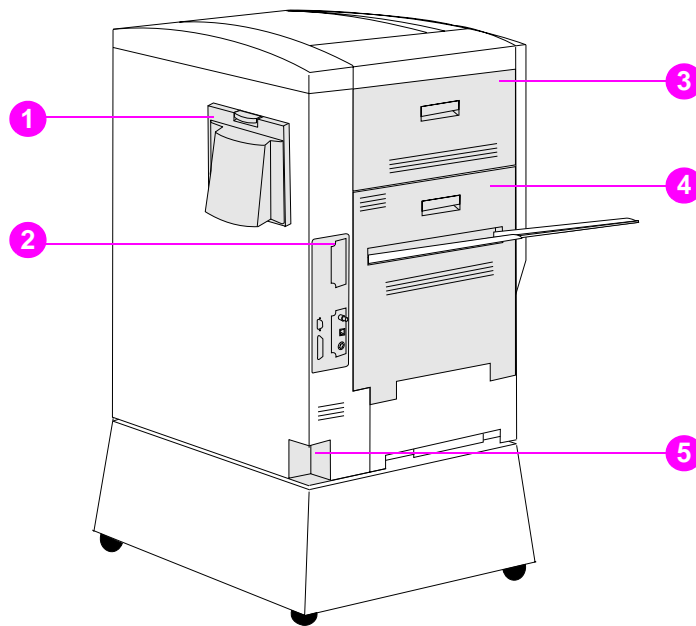
### External views



**Figure 3.**

#### Front view

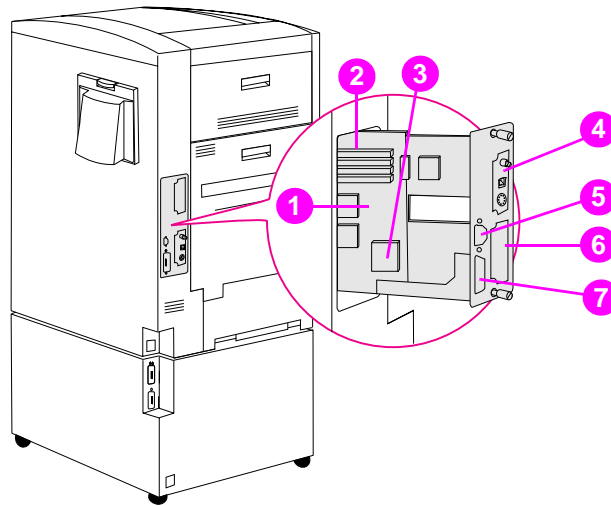
- |   |                                     |    |                            |
|---|-------------------------------------|----|----------------------------|
| 1 | Printer control panel (see page 66) | 7  | Top (face-down) output bin |
| 2 | Left (face-up) output bin           | 8  | Flip-up media stop         |
| 3 | Front door                          | 9  | Right upper cover          |
| 4 | Input tray 2                        | 10 | Input tray 1               |
| 5 | Power button                        | 11 | Right lower cover          |
| 6 | Input tray 3                        | 12 | Printer stand              |



**Figure 4.** Rear view

- 1 Air filter door
- 2 Formatter board
- 3 Left upper cover
- 4 Left lower cover
- 5 Power connector

## Formatter assemblies



**Figure 5.** Formatter assemblies

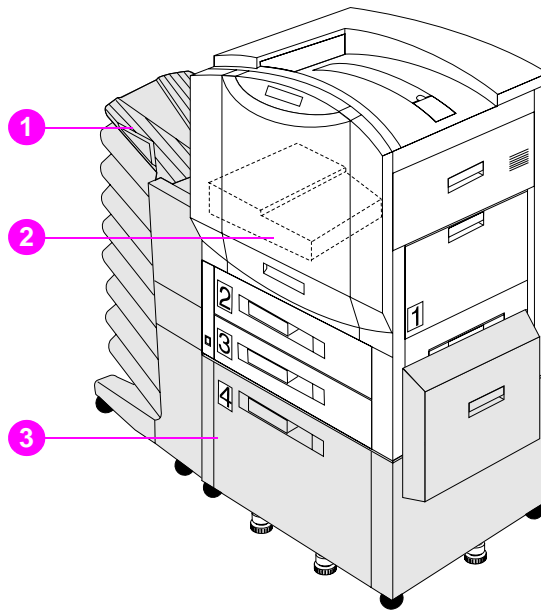
- 1 Formatter board
- 2 DIMM slots
- 3 Printer hard disk location (factory installed)
- 4 EIO slot 2 (shown with HP JetDirect internal print server)
- 5 Parallel IEEE-1284 interface port (C-size)
- 6 EIO slot 1
- 7 C-link connector

---

**Note** Either EIO slot can have a hard disk installed if there is not a factory installed internal hard drive mounted on the formatter board.

---

## Paper handling accessories and options



**Figure 6.** Paper handling accessories and options

- 1 Multi-bin mailbox
- 2 Duplexer (internal)
- 3 2,000-sheet input unit (only available on 8500 DN model)



## Safety information

### FCC regulations

This equipment has been tested and found to comply with the limits for a Class B digital device, pursuant to Part 15 of the FCC rules. These limits are designed to provide reasonable protection against harmful interference in a residential installation. This equipment generates, uses, and can radiate radio frequency energy, and if not installed and used in accordance with the instructions, may cause harmful interference to radio communications. However, there is no guarantee that interference will not occur in a particular installation. If this equipment does cause harmful interference to radio or television reception, which can be determined by turning the equipment off and on, the user is encouraged to try to correct the interference by one or more of the following measures:

- Reorient or relocate the receiving antenna.
- Increase separation between equipment and receiver.
- Connect equipment to an outlet on a circuit different from that on which the receiver is located.
- Consult your dealer or an experienced radio/television technician.

---

#### Note

Any changes or modifications to the printer not expressly approved by HP could void the user's authority to operate this equipment.

Use of a shielded interface cable is required to comply within the Class B limits in Part 15 of FCC rules.

---

### Canadian DOC regulations

Complies with Canadian EMC Class B requirements.

«Conforme à la classe B des normes canadiennes de compatibilité électromagnétiques. «CEM».»

# Declarations of conformity

## DECLARATION OF CONFORMITY

according to ISO/IEC Guide 22 and EN 45014

**Manufacturer's Name:** Hewlett-Packard Company  
**Manufacturer's Address:** 11311 Chinden Boulevard  
Boise, Idaho 83714-1021, USA

**declares, that the product**

**Product Name:** HP Color LaserJet 8500, 8500 N, 8500 DN  
**Model Number:** C3983A, C3984A, C3985A  
**Product Options:** ALL

### conforms to the following Product Specifications:

**Safety:** IEC 950:1991+A1+A2+A3+A4 / EN 60950:1992+A1+A2+A3+A4  
IEC 825-1:1993 / EN 60825-1:1994 Class 1 (Laser/LED)

**EMC:** CISPR 22:1993+A1 / EN 55022:1994 Class B<sup>1</sup>  
CISPR 22:1993+A1 / EN 55022:1994 Class A\*  
EN 5081-1:1992  
EN 50082-1:1992  
IEC 801-2:1991 / prEN 55024-2:1992 -4 kV CD, 8 kV AD  
IEC 801-3:1984 / prEN 55024-3:1991 -3 V/m  
IEC 801-4:1988 / prEN 55024-4:1992 -0.5 kV Signal Lines  
1.0 kV Power Lines  
FCC Title 47 CFR, Part 15 Class B<sup>2</sup>/ICES-003, Issue 2/VCCI-2<sup>1</sup>  
AS / NZS 3548:1992 / CISPR 22:1993 Class<sup>1</sup>

### Supplementary Information:

The product herewith complies with the requirements of the following Directives and carries the CE-marking accordingly:

- the EMC directive 89/336/EEC
- the Low Voltage Directive 73/23/EEC

<sup>1</sup> The product was tested in a typical configuration with Hewlett-Packard Personal Computer Systems.

<sup>2</sup> This Device complies with Part 15 of the FCC rules. Operation is subject to the following two conditions:

(1) this device may not cause harmful interference, and (2) this device must accept any interference received, including interference that may cause undesired operation.

\* This printer contains Local Area Network (LAN) options. When the interface cable is attached to either of the IEEE 802.3 connectors, the printer meets the requirements of EN55022 Class A.

February 12, 1997

### For Compliance Information ONLY, contact:

**Australia Contact:** Product Regulations Manager, Hewlett-Packard Australia Ltd., 31-41 Joseph Street, Blackburn, Victoria 3130, Australia

**Europe Contact:** A Local Hewlett-Packard Sales and Service Office or Hewlett-Packard GmbH, Department HQ-TRE / Standards Europe, Herrenberger Strasse 130, D-71034 Böblingen (Fax: +49-7031-14-3143)

**USA Contact:** Product Regulations Manager, Hewlett-Packard Company, P.O. Box 15 Mail Stop 160, Boise, ID 83707-0015 (Phone: 208-396-6000)

## DECLARATION OF CONFORMITY

according to ISO/IEC Guide 22 and EN 45014

**Manufacturer's Name:** Hewlett-Packard Company  
**Manufacturer's Address:** Montemorelos 299  
Guadalajara Jalisco, 45060  
México

**declares, that the product**

**Product Name:** Duplexer  
**Model Number:** C4782A  
**Product Options:** N/A

**conforms to the following Product Specifications:**

EMC: CISPR 22:1993+A1 / EN 55022:1994 Class B<sup>1</sup>  
CISPR 22:1993+A1 / EN 55022:1994  
EN 50081-1:1992  
EN 50082-1:1992  
IEC 801-2:1991 / prEN 55024-2:1992 -4 kV CD, 8 kV AD  
IEC 801-3:1984 / prEN 55024-3:1991 -3 V/m  
IEC 801-4:1988 / prEN 55024-4:1992 -0.5 kV Signal Lines  
1.0 kV Power Lines  
FCC Title 47 CFR, Part 15 Class B<sup>2</sup>/ICES-003, Issue 2/VCCI-2<sup>1</sup>  
AS / NZS 3548:1992 / CISPR 22:1993 Class B<sup>1</sup>

### Supplementary Information:

The product herewith complies with the requirements of the following Directives and carries the CE-marking accordingly:

- the EMC directive 89/336/EEC
- the Low Voltage Directive 73/23/EEC

<sup>1</sup> The product was tested in a typical configuration with Hewlett-Packard Personal Computer Systems.

<sup>2</sup> This Device complies with Part 15 of the FCC rules. Operation is subject to the following two conditions:

(1) this device may not cause harmful interference, and (2) this device must accept any interference received, including interference that may cause undesired operation.

July 16, 1997

### For Compliance Information ONLY, contact:

Australia Contact: Product Regulations Manager, Hewlett-Packard Australia Ltd., 31-41 Joseph Street, Blackburn, Victoria 3130, Australia

Europe Contact: A Local Hewlett-Packard Sales and Service Office or Hewlett-Packard GmbH, Department HQ-TRE / Standards Europe, Herrenberger Strasse 130, D-71034 Böblingen (Fax: +49-7031-14-3143)

USA Contact: Product Regulations Manager, Hewlett-Packard Company, P.O. Box 15 Mail Stop 160, Boise, ID 83707-0015 (Phone: 208-396-6000)

## DECLARATION OF CONFORMITY

according to ISO/IEC Guide 22 and EN 45014

**Manufacturer's Name:** Hewlett-Packard Company  
**Manufacturer's Address:** Montemorelos 299  
Guadalajara Jalisco, 45060  
México

**declares, that the product**

**Product Name:** 2,000-Sheet Input Tray  
**Model Number:** C4781A  
**Product Options:** N/A

### conforms to the following Product Specifications:

**Safety:** IEC 950:1991+A1+A2+A3+A4 / EN 60950:1992+A1+A2+A3+A4  
IEC 825-1:1993 / EN 60825-1:1994 Class 1 (Laser/LED)

**EMC:** CISPR 22:1993+A1 / EN 55022:1994 Class B<sup>1</sup>  
CISPR 22:1993+A1 / EN 55022:1994  
EN 50081-1:1992  
EN 50082-1:1992  
IEC 801-2:1991 / prEN 55024-2:1992 -4 kV CD, 8 kV AD  
IEC 801-3:1984 / prEN 55024-3:1991 -3 V/m  
IEC 801-4:1988 / prEN 55024-4:1992 -0.5 kV Signal Lines  
1.0 kV Power Lines  
FCC Title 47 CFR, Part 15 Class B<sup>2</sup>/ICES-003, Issue 2/VCCI-2<sup>1</sup>  
AS / NZS 3548:1992 / CISPR 22:1993 Class B<sup>1</sup>

### Supplementary Information:

The product herewith complies with the requirements of the following Directives and carries the CE-marking accordingly:

- the EMC directive 89/336/EEC
- the Low Voltage Directive 73/23/EEC

<sup>1</sup> The product was tested in a typical configuration with Hewlett-Packard Personal Computer Systems.

<sup>2</sup> This Device complies with Part 15 of the FCC rules. Operation is subject to the following two conditions:

(1) this device may not cause harmful interference, and (2) this device must accept any interference received, including interference that may cause undesired operation.

July 16, 1997

### For Compliance Information ONLY, contact:

**Australia Contact:** Product Regulations Manager, Hewlett-Packard Australia Ltd., 31-41 Joseph Street, Blackburn, Victoria 3130, Australia

**Europe Contact:** A Local Hewlett-Packard Sales and Service Office or Hewlett-Packard GmbH, Department HQ-TRE / Standards Europe, Herrenberger Strasse 130, D-71034 Böblingen (Fax: +49-7031-14-3143)

**USA Contact:** Product Regulations Manager, Hewlett-Packard Company, P.O. Box 15 Mail Stop 160, Boise, ID 83707-0015 (Phone: 208-396-6000)

## VCCI statement (Japan)

この装置は、情報処理装置等電波障害自主規制協議会（VCCI）の基準に基づくクラスB情報技術装置です。この装置は、家庭環境で使用することを目的としていますが、この装置がラジオやテレビジョン受信機に近接して使用されると、受信障害を引き起こすことがあります。  
取り扱い説明書に従って正しい取り扱いをして下さい。

## EMI statement (Korea)

### 사용자 안내문 (B급 기기)

이 기기는 비업무용으로 전자파장해검정을 받은 기기로서, 주거지역에서는 물론 모든 지역에서 사용할 수 있습니다.

## Laser safety statement

The Center for Devices and Radiological Health (CDRH) of the U.S. Food and Drug Administration has implemented regulations for laser products manufactured since August 1, 1976. Compliance is mandatory for products marketed in the United States. This printer is certified as a "Class 1" laser product under the U.S. Department of Health and Human Services (DHHS) Radiation Performance Standard according to the Radiation Control for Health and Safety Act of 1968. Since radiation emitted inside this printer is completely confined within protective housings and external covers, the laser beam cannot escape during any phase of normal user operation.

## Laser statement for Finland

### Luokan 1 laserlaite

#### Klass 1 Laser Apparat

HP LaserJet 8500, 8500 N, 8500 DN laserkirjoitin on käyttäjän kannalta turvallinen luokan 1 laserlaite. Normaalisessa käytössä kirjoittimen suojakoteloitinta estää lasersäteiden pääsyn laitteen ulkopuolelle. Laitteen turvallisuusluokka on määritetty standardin EN 60825-1 (1994) mukaisesti.

#### Varoitus!

Laitteen käyttäminen muulla kuin käyttöohjeessa mainitulla tavalla saattaa altistaa käyttäjän turvallisuusluokan 1 ylittävälle näkymättömälle lasersäteilylle.

#### Varning!

Om apparaten används på annat sätt än i bruksanvisning specificerats, kan användaren utsättas för osynlig laserstrålning, som överskrider gränsen för laserklass 1.

#### HUOLTO

HP LaserJet 8500, 8500 N, 8500 DN -kirjoittimen sisällä ei ole käyttäjän huollettavissa olevia kohteita. Laitteen saa avata ja huoltaa ainoastaan sen huoltamiseen koulutettu henkilö. Tällaiseksi huoltotoimenpiteeksi ei katsota väriainekasetin vaihtamista, paperiradan puhdistusta tai muita käyttäjän käsikirjassa lueteltuja, käyttäjän tehtäväksi tarkoitettuja ylläpitotoimia, jotka voidaan suorittaa ilman erikoistyökaluja.

#### Varo!

Mikäli kirjoittimen suojakotelo avataan, olet alttiina näkymättömälle lasersäteilylle laitteen ollessa toiminnassa. Älä katso säteeseen.

#### Varning!

Om laserprinterns skyddshölje öppnas då apparaten är i funktion, utsättas användaren för osynlig laserstrålning. Betrakta ej strålen.

Tiedot laitteessa käytettävän laserdiodin säteilyominaisuuksista:

Aallonpituus 775-795 nm

Teho 5 mW

Luokan 3B laser

## **Product information sheet**

The Toner Product Information Sheet can be obtained by calling U.S. HP FIRST (Fax Information Retrieval Support Technology) at (1) (800) 231-9300. International customers should see page 52 for appropriate phone numbers and information.

## **Toner safety**

Toner is composed of plastic and a small amount of pigment. Avoid breathing toner particles; toner might be harmful to your health. Toner can also stain clothing. Skin and clothing are best cleaned by removing as much toner as possible with a dry tissue, then washing with cold water. Hot water causes toner to melt and permanently fuse into clothing.

## **Material Safety Data Sheet**

The Toner Cartridge/Drum MSDS can be obtained by calling U.S. HP FIRST (Fax Information Retrieval Support Technology) at (1) (800) 231-9300. Use Index number 7 for a listing of the Toner Cartridge/Drum Material/Chemical Safety Data Sheets. International customers should see page 52 for appropriate phone numbers and information.

## Ozone safety

### Ozone emission

The corona assemblies found in laser printers and photocopiers generate ozone gas (O<sub>3</sub>) as a by-product of the electrophotographic process. Ozone is generated only while the printer is printing (while the coronas are energized).

This HP LaserJet printer contains an charcoal filter to protect office air quality. See page 105 for suggested replacement intervals.

### Ozone standards

Standards for exposure to ozone have been established by the Department of Labor - Occupational Safety and Health Administration (DOL-OSHA) and the American Conference of Governmental Industrial Hygienists (ACGIH). These standards are 0.1 parts per million as a time-weighted average and a ceiling limit respectively. All HP LaserJet family printers meet these standards when shipped from the factory.

### Recommendations for minimizing ozone exposure

Some people are extremely sensitive to ozone. In such cases, it is advisable to position the printer away from the sensitive user. Also, a more frequent filter replacement might be necessary.

Almost all ozone concerns arise from abnormal site or operating conditions. The following conditions might generate an ozone complaint:

- installation of multiple laser printers in a confined area
- extremely low relative humidity
- poor room ventilation
- the exhaust port of the printer is directed towards the face of personnel
- the existing ozone filter is in poor condition
- long, continuous printing combined with any of the above

Inspect your work environment for the operating conditions listed above if you believe ozone emissions are a problem in your area. (Your employer is responsible for providing a work environment that is free of these conditions.)



# 2 Service approach

## Chapter contents

Introduction . . . . .	49
Parts and supplies . . . . .	49
Ordering information . . . . .	49
Obtaining related documentation and software . . . . .	50
List server . . . . .	50
Ordering consumables . . . . .	51
Ordering field replaceable units . . . . .	51
Parts exchange program . . . . .	51
Technical assistance . . . . .	52
HP ASAP . . . . .	52
Dealer Response Line . . . . .	53
HP Software Distribution Center . . . . .	53
HP Direct . . . . .	53
Customer Support Sales Center . . . . .	53
Parts identification . . . . .	53
Customer Information Centers . . . . .	53
HP Customer Care Centers (CCC) . . . . .	54
Warranty . . . . .	55
Installation . . . . .	55
Toner cartridge information . . . . .	55



## Introduction

Repair normally begins with using the printer internal diagnostics in conjunction with the troubleshooting procedures in chapter 7. Once a faulty part is located, repair is generally accomplished by assembly-level replacement of the field replaceable units. Some mechanical assemblies can be repaired at the subassembly level. PCA component replacement is not supported by Hewlett-Packard.

## Parts and supplies

Field replaceable and accessory part numbers are found in chapter 8 of this manual. Use only accessories specifically designed for this printer. Accessories can be ordered from an authorized service or support provider. For a list of available accessories and their part numbers, see page 445. Replacement parts can be ordered from HP's Service Materials Organization (SMO) or Support Materials Europe (SME).

### Ordering information

The following table lists information for ordering from SME, SMO, and HP Distribution Center (HPD).

**Table 10. Ordering information**

Organization	Address	Phone
SMO (Service Materials Organization)	Hewlett-Packard Company Support Materials Organization 8050 Foothills Blvd. Roseville, CA 95678	(1) (800) 227-8164 (U.S. only)
SME (Support Materials Europe)	Hewlett-Packard Company Support Materials Europe Wolf-Hirth Strasse 33 D-7030 Böblingen, Germany	(49 7031) 14-2253
HPD (HP Distribution Center)		(805) 257-5565 (805) 257-6995 Fax

## Obtaining related documentation and software

To order related documentation and software, contact SMO or SME at the numbers listed on the previous page. Part numbers for related documentation are listed beginning on page 448.

For information through the World Wide Web, visit the following websites:

**Table 11. Technical support websites**

<b>HP Customer Care Online</b> Software drivers, support documentation, and answers to frequently asked questions.	<a href="http://www.hp.com/go/support">http://www.hp.com/go/support</a>
<b>HP Technical Training (North America)</b> Classes and schedules	<a href="http://www.hp.com/go/resellertraining">http://www.hp.com/go/resellertraining</a>
<b>Parts</b> Parts information	<a href="http://outfield.external.hp.com/spi/welcom.htm">http://outfield.external.hp.com/spi/welcom.htm</a>

## List server

A list server is a mail program that allows users to subscribe or unsubscribe to certain mail lists by sending e-mail to the server. Once subscribed, a user receives all messages sent to the list name. The following list server will allow HP LaserJet technical marketing to make the support community aware of new or urgent information by pushing the information out to those who subscribe to a list.

To subscribe to the HP LaserJet hardware external list server, send e-mail to: [Listserv@HPBS8305.boi.hp.com](mailto:Listserv@HPBS8305.boi.hp.com) with the word "subscribe" (no quotes), the list name (lj-hardware-external), and your name in the text of the message.

Example: Subscribe lj-hardware-external John Doe.

Within each list subscribers can filter which products they want information on by typing the product name in the subject line of the subscription message. To view an updated available list on the server, send e-mail to: [listserv@hpbs8305.boi.hp.com](mailto:listserv@hpbs8305.boi.hp.com) with the text: List Global.

Once you subscribe, you will receive further instruction on the use and benefits of this list server.

## Ordering consumables

Consumable parts and accessories are available directly from Hewlett-Packard at the following numbers:

- U.S.: (1) (800) 538-8787
- Canada: (1) (800) 387-3154  
(in Toronto: (416) 671-8383)
- United Kingdom: 0734-441212
- Contact your local HP Parts Coordinator for other local phone numbers.

To find a dealer near you (or if the local dealer is temporarily out of stock), call the HP Customer Information Center at (1) (800) 752-0900.

## Ordering field replaceable units

This printer is designed to be repaired by replacing field replaceable units. Part numbers are located in chapter 8 of this manual and can be ordered from SMO or SME (see page 49).

## Parts exchange program

HP offers remanufactured assemblies for some selected parts. These are identified in chapter 8 and can be ordered through SMO or SME (see page 49).

## Technical assistance

### HP ASAP

HP ASAP (Automated Support Access Program) provides free technical support information 24 hours a day, 7 days a week. The ASAP system includes HP FIRST, explained below. The ASAP service at (1) (800) 333-1917 (U.S.) requires a touchtone phone.

### HP FIRST

HP FIRST (Fax Information Retrieval Support Technology) is a phone-in fax service providing technical information for HP LaserJet end-users as well as service personnel. Receiving a fax requires a type 3 facsimile machine or fax card. Service-related information includes:

- service notes (HP Authorized Dealers)
- Product Data Sheets
- Material Safety Data Sheets (MSDSs)
- typeface and accessory information
- printer support software information
- toner information
- driver request form and Software Matrix

### HP FIRST, U.S.

Call the HP ASAP system at (1) (800) 333-1917 and follow the voice prompts to enter HP FIRST.

### HP FIRST, Europe

Call HP FIRST at one of the following numbers:

- U.K: 0800-96-02-71
- Belgium: 078-111906 (Dutch)
- Switzerland: 155-1527 (German)
- Netherlands: 06-0222420
- Germany: 0130-810061
- Austria: 0660-8128

For English service outside the countries listed above, call (31) 20-681-8192.

## **Dealer Response Line**

For further technical assistance on pre/post sales and service support, HP dealer service-authorized personnel can contact the Dealer Response Line.

- (1) (800) 544-9976 U.S. only
- (1) (800) 363-6584 Canada

## **HP Software Distribution Center**

For printer drivers and application note orders:

- (805) 257-5565

## **HP Direct**

For supplies and accessories orders:

- (1) (800) 538-8787 U.S. only

## **Customer Support Sales Center**

For existing hardware and software service agreements:

- (1) (800) 386-1115 U.S. only

For quotes on or purchase of new hardware or software agreements:

- (1) (800) 743-8305 U.S. only

## **Parts identification**

For service part number identification:

- (1) (916) 783-0804

## **Customer Information Centers**

For further technical assistance, service-authorized HP and dealer service personnel can contact the nearest Hewlett-Packard Customer Information Center at (1) (800) 752-0900 in North America.

## **HP Customer Care Centers (CCC)**

HP representatives are available to answer technical questions at no charge for a period equivalent to the original HP hardware warranty period.

Questions regarding operating systems such as MS-DOS®, UNIX®, or network configuration operating systems cannot be answered by the Customer Care Center, and should be referred to your dealer.

---

**Note**

---

Each time you call the HP Customer Care Centers, you will be asked to provide the printer serial number and the original date of purchase.

### **U.S. Customer Care Center (CCC)**

The CCC can be reached at (208) 323-2551 and is available weekdays from 6:00 am to 6:00 pm Mountain Standard Time.

### **European Customer Care Center (ECCC)**

The ECCC can be reached at 31-0-20-605-0505 and is available weekdays from 8:30 am until 6:00 pm Central European Time. Multilingual customer support representatives are available to answer questions.

### **Canadian Customer Care Center (CCCC)**

The CCCC at (905) 206-4663 is available weekdays from 8:00 am until 8:00 pm Eastern Standard Time. French- and English-speaking customer support representatives are available to answer questions.



## Warranty

The warranty outlines specific legal rights. There might also be other rights which vary from area to area. Refer to the user's guide for further warranty information.

### Installation

Installation by service personnel is optional with the HP Color LaserJet 8500 and 8500 N models, and is included with the 8500 DN model. Installation can be arranged through the service center.

### Toner cartridge information

The toner cartridge is designed to simplify replacement of the major "consumable" parts. The toner cartridge contains part of the printing mechanism and a supply of toner.

---

#### Note

---

For best results, always use a toner cartridge before the expiration date stamped on the toner cartridge box.

### Refilled toner cartridges

While HP does not prohibit the use of refilled toner cartridges during the warranty period or while the printer is under a maintenance contract, it is not recommended for the following reasons:

- Repairs resulting from the use of refilled toner cartridges are not covered under HP warranty or maintenance contracts.
- HP has no control or process to ensure that a refilled toner cartridge functions at the high level of reliability of a new HP LaserJet toner cartridge. HP also cannot predict what the long-term reliability effect on the printer is from using different toner formulations found in refilled cartridges.
- The print quality of HP LaserJet toner cartridges influences the customer's perception of the printer. HP has no control over the actual print quality of a refilled toner cartridge.

### Recycling toner cartridges

In order to reduce waste, HP offers a recycling program for used toner cartridges. Cartridge components that do not wear out are recycled. Plastics and other materials are recycled. HP pays the shipping costs from the user to the recycling facility.



# 3 Operational overview

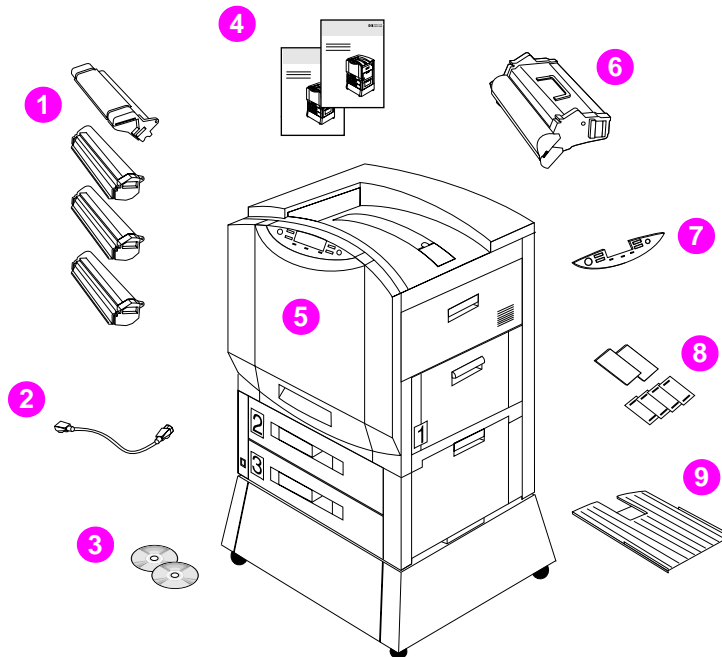
## Chapter contents

Verifying package contents . . . . .	59
Verifying the cables are installed. . . . .	60
Printer with stand. . . . .	60
Printer with a 2,000-sheet input unit . . . . .	61
Connecting the printer to the network . . . . .	62
Connecting to a 10Base-T or 100Base-TX network . . . . .	63
Connecting to a 10Base2 network. . . . .	63
Connecting to a LocalTalk network . . . . .	63
Connecting a parallel cable . . . . .	64
Changing the printer control panel overlay . . . . .	65
Printer control panel layout . . . . .	66
Menu maps . . . . .	68
Information Menu. . . . .	71
Proof and Print Menu. . . . .	72
Paper Handling Menu . . . . .	72
Configuration Menu . . . . .	75
Printing Menu . . . . .	76
I/O Menu . . . . .	78
Resets Menu . . . . .	78
Color Adjust Menu. . . . .	79
Service Mode Menu. . . . .	80

Selecting the display language . . . . .	84
Installing the consumables . . . . .	85
Configuring input trays . . . . .	90
Selecting the mode for tray 1 . . . . .	90
Configuring media type and size . . . . .	91
Verifying the printer is installed correctly . . . . .	92
Verifying DIMM installation . . . . .	93
Paper handling accessory status LEDs. . . . .	94

## Verifying package contents

Verify the following items were included from the factory:



**Figure 7.** Contents of printer box

- 1 Four toner cartridges: black, cyan, magenta, and yellow
- 2 Power cord
- 3 Software on CD-ROM
- 4 Manuals: getting started guide and quick reference guide
- 5 Printer (shown with standard printer stand)
- 6 Imaging drum
- 7 Printer control panel overlay (if applicable)
- 8 Media size labels
- 9 Left (face-up) output bin

---

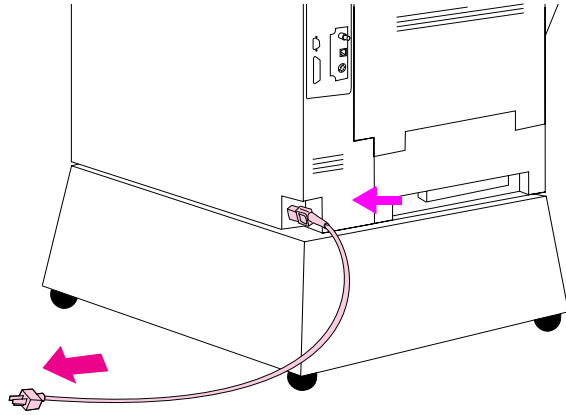
**Note** If a 2,000-sheet input unit was ordered, it replaces the printer stand. A power box and a C-link cable are also included.

---

## Verifying the cables are installed

Verify that the cables are connected to the printer correctly.

### Printer with stand



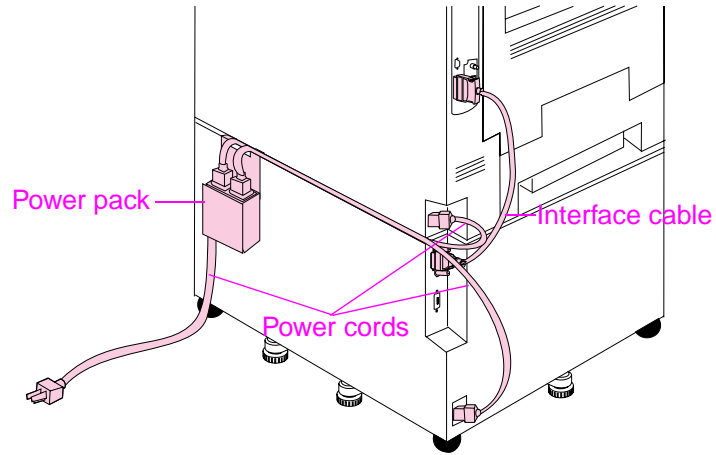
**Figure 8.** Power cord connection

#### **WARNING!**

An unstable printer can tip over and cause injury; verify that the printer is secured properly and the printer wheels are locked.

- The power cord plugs into the connector on the back left corner of the printer and into a surge protector or other grounded power source.

## Printer with a 2,000-sheet input unit



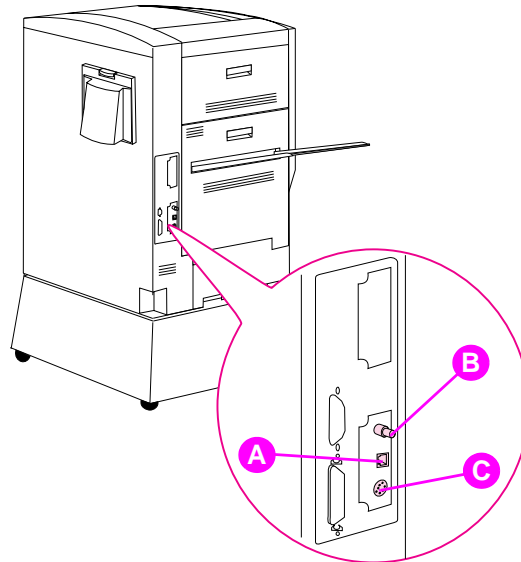
**Figure 9.** C-link and power cables connections

- The interface cable attaches to the printer above the parallel connector and to the connector on the 2,000-sheet input unit.
- The power pack attaches to the back of the printer.
- The shorter of the two cables from the power pack plugs into the connector on the back left corner of the printer.
- The longer of the two cables from the power pack plugs into the connector on the back left corner of the 2,000-sheet input unit.
- The power cord plugs into the bottom of the power pack and into a surge protector or other grounded power source.

## Connecting the printer to the network

If the printer was shipped with an optional HP JetDirect internal print server, one of two types is installed:

- HP JetDirect Ethernet print server supports up to three different network interface cables—RJ-45 (unshielded twisted pair) for 10Base-T networks, BNC (coaxial) for 10Base2 networks, and DIN-8 for LocalTalk networks. This print server supports only one Ethernet connection at a time—RJ-45 or BNC.
- HP JetDirect 10/100TX print server supports RJ-45 (unshielded twisted pair) for 10Base-T or 100Base-TX networks.



**Figure 10.** Network connections

The locations of ports on the HP JetDirect internal printer server are:

- A** RJ-45 port (this is the only connector available with the HP JetDirect 10/100TX card)
- B** BNC port
- C** LocalTalk (DIN-8) port



## Connecting to a 10Base-T or 100Base-TX network

- The connector of the unshielded twisted pair network cable plugs into the RJ-45 port.

## Connecting to a 10Base2 network

- Attach one section of the ThinLAN (coaxial) cable to a BNC “T” connector.
- Attach another ThinLAN cable section, or (if it is at the end of the network) a 50-ohm terminator on the other side of the BNC “T” connector.
- Plug the BNC “T” connector into the BNC port.

## Connecting to a LocalTalk network

- Plug the end of the DIN-8 cable into the LocalTalk port.

---

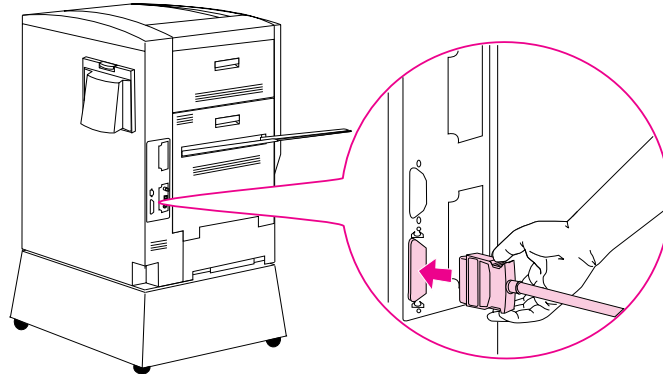
### Note

The printer can be connected to a LocalTalk network in addition to an Ethernet or 10Base2 network.

If you use only the LocalTalk port, EIO 1 INITIALIZING appears every time you turn the printer on if you have an HP JetDirect internal print server installed in EIO port 1. The message should not interfere with normal printing through LocalTalk. If it does not clear within approximately five minutes, there is a problem with the print server or the network. To prevent the message from appearing during normal operation, connect a BNC “T” connector with two 50-ohm terminators to the BNC port.

---

## Connecting a parallel cable

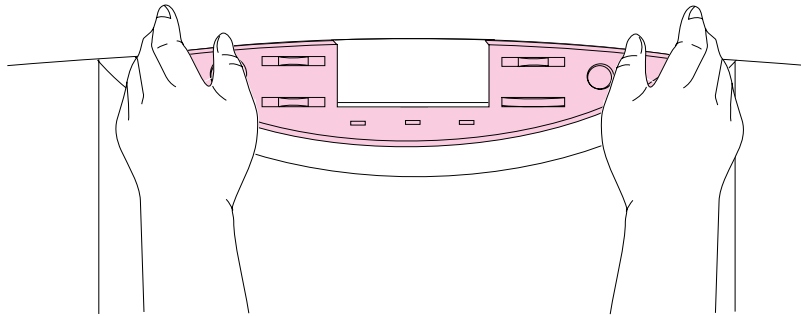


**Figure 11.** Parallel cable connection

- To print through the parallel port, the printer requires a 25-pin male/micro 36-pin male (“C-size”) parallel cable that is IEEE-1284 compliant. The cable is included with the base model of this printer only. It must be purchased separately for other printer models.

## Changing the printer control panel overlay

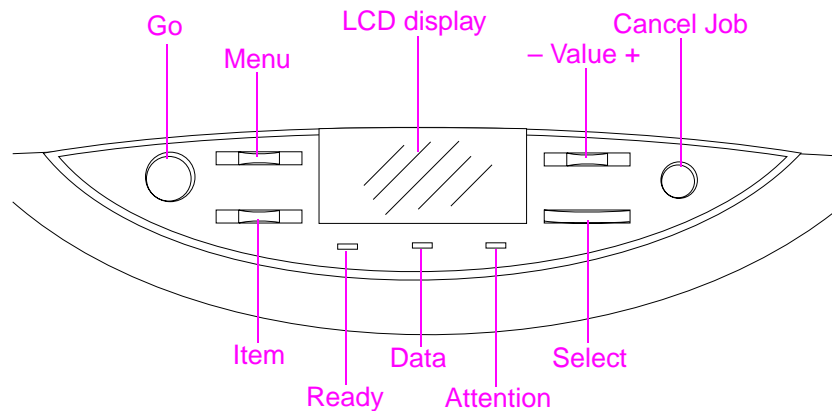
Replace the printer control panel overlay with the one included for your language, if applicable. Then configure the printer control panel to show printer messages in your language (see page 84).



**Figure 12.** Changing the printer control panel overlay

- 1** Insert a thin, rigid object under the two edges of the overlay on the printer control panel and pull up evenly on both sides of the overlay until it comes off.
- 2** Place the new overlay over the printer control panel and snap it into place.

## Printer control panel layout



**Figure 13.** Location of printer control panel features

<b>Go</b>	Brings the printer online or offline, exits menus, and will override load tray messages to print on the default media size and type.
<b>Menu</b>	Accesses the printer control panel menus to set the printer defaults. This key permits both forward and backward movement through the list of available menus.
<b>LCD display</b>	Presents data about the printer (such as printer status, required actions, or data and print errors) in one or two lines of characters.
<b>– Value +</b>	Steps through the value choices for a particular menu item using – or +. This key permits both forward and backward movement through the values.
<b>Cancel Job</b>	Stops the current job from printing. If no job is printing and the display indicates that a job is processing, <b>CANCEL JOB</b> cancels the currently processing job and the next job begins printing. While the job is being canceled, <b>CANCELING JOB</b> is displayed.
<b>Item</b>	Steps through the items in a particular menu. This key permits both forward and backward movement through the available items.

**Ready Indicator**  
(green)

- On—The printer is online and able to accept and process data.
- Off—The printer is offline and unable to accept or process data.
- Flashing—The printer is going from online to offline, or from offline to online.

**Data Indicator**  
(green)

- On—Data is in the printer buffer, or the printer is processing data.
- Off—The printer buffer is empty.
- Flashing—The printer is receiving or processing data.

**Attention Indicator**  
(amber)

- On—An error has occurred in the printer.
- Off—The printer does not require attention.
- Flashing—The printer requires attention.

**Select**

Selects the item or value currently shown on the printer control panel display. An asterisk (\*) is displayed when an item has been selected.

## Menu maps

Press **MENU** to cycle through the printer control panel menus. Each menu is described in a separate table in this section. Menu items are displayed only if their associated option or function is installed or activated.

All menus and their associated items are accessible when the printer is online. In a menu mode, if no keys are pressed for approximately 30 seconds, the system automatically returns to the top level and displays one of the following:

- READY if the printer was online
- OFFLINE if the printer was offline
- an existing error or service message

### Making selections in the printer control panel menus

- 1 Press **MENU** until the menu you want appears on the printer control panel display.
- 2 Press **ITEM** until the item you want appears on the display.
- 3 Press **- VALUE +** until the value you want appears on the display.
- 4 Press **SELECT** to save the selection. An asterisk (\*) appears to the right of the selection.
- 5 Repeat steps 1 through 4 until all of your changes are complete.
- 6 Press **GO** to bring the printer online.

---

#### Note

Changes in the printer control panel will not take effect until all current data in the print buffer prints or until the next print job.

**Table 12. Printer control panel menu map overview**

INFORMATION MENU	PROOF AND PRINT MENU	PAPER HANDLING MENU	CONFIGURATION MENU	PRINTING MENU
PRINT MENU MAP	<job name> <job owner>	TRAY 1 MODE=	POWERSAVE=	COPIES=
PRINT CONFIG PAGE		TRAY 1 TYPE= <sup>1</sup>	PERSONALITY=	PAPER= <sup>2</sup>
PRINT PCL FONT LIST		TRAY 1 SIZE= <sup>1</sup>	CLEARABLE WARNINGS=	ENVELOPE= <sup>2</sup>
PRINT PS FONT LIST		TRAY 2 TYPE=	TONER LOW=	ORIENTATION=
PRINT LASERJET DEMONSTRATION		TRAY 3 TYPE=	PRINT PS ERRORS=	FORM LENGTH=
PRINT FILE DIRECTORY		TRAY 4 TYPE=	INITIALIZE DISK	PCL FONT SOURCE=
PRINT EIO PAGE		PAPER DEST=		PCL FONT NUMBER=
PRINT CONTINUOUS CONFIG PAGES		DUPLEX=		PCL PITCH=
PRINT EVENT LOG		BINDING=		PCL POINT SIZE=
		MANUAL FEED=		PCL SYMBOL SET=
	OVERVERRIDE A4 WITH LETTER=		COURIER=	
	AUTO PAPER OVERRIDE=		WIDE A4=	
			APPEND CR TO LF=	

<sup>1</sup> Appears only if TRAY 1 MODE = CASSETTE.

<sup>2</sup> Shows PAPER for sizes that are normally sheets of paper, and shows ENVELOPE for sizes that are normally envelopes.

**Table 12. Printer control panel menu map overview (continued)**

I/O MENU	RESETS MENU	COLOR ADJUST MENU	SERVICE MODE MENU <sup>3</sup>
I/O TIMEOUT=  PARALLEL ADV FUNCTIONS=	FACTORY DEFAULT RESET  RESET ACTIVE I/ O  RESET ALL I/O  RESET TRANSFER LIFE COUNT  RESET FUSER LIFE COUNT	PRINT TEST PAGE  BLACK SMOOTH VALUE=  CYAN SMOOTH VALUE=  MAGENTA SMOOTH VALUE=  YELLOW SMOOTH VALUE=  BLACK DETAIL VALUE=  CYAN DETAIL VALUE=  MAGENTA DETAIL VALUE=  YELLOW DETAIL VALUE=	NVRAM SETTING  FORMATTER DIAGNOSTICS  PAPER PATH  DEVELOPER MOTOR  DRUM MOTOR  SENSOR MONITOR  EXIT SERVICE MODE

<sup>3</sup> The Service Mode Menu can only be entered by pressing –VALUE and –ITEM keys at the same time. The menu items will not be visible until the Service Mode Menu is entered.



## Information Menu

Press **SELECT** to print.

The printer displays READY when finished.

**Table 13. Information Menu**

Item	Value	Description / action
PRINT MENU MAP	None	Shows current settings of all menu items.
PRINT CONFIG PAGE	None	Shows the configuration of the printer including installed options and serial numbers.
PRINT PCL FONT LIST	None	Shows installed PCL fonts including soft fonts.
PRINT PS FONT LIST	None	Shows installed PostScript fonts.
PRINT LASERJET DEMONSTRATION	None	Prints a demonstration page for sales purposes.
PRINT FILE DIRECTORY	None	Appears only if the printer has a hard disk installed.
PRINT EIO PAGE	None	Appears only if an EIO device is installed that supports EIO page printing.
PRINT CONTINUOUS CONFIG PAGES	None	Used for testing printer operation.
PRINT EVENT LOG	None	Shows printer events.

## Proof and Print Menu

This menu appears only if the printer has a hard disk installed.

**Table 14. Proof and Print Menu**

Item	Value	Description / action
<job name> <job owner>	<nn> SELECTED <nn> PRINTED	<nn> = Number of copies
<job name> <job owner>	<nn> SELECTED <nn> PRINTED	To cancel a proof and print job:
<ob name> <job owner>	<nn> SELECTED <nn> PRINTED	1 Press <b>ITEM</b> to display the job name and job owner.
<job name> <job owner>	<nn> SELECTED <nn> PRINTED	2 Press <b>- VALUE +</b> to change the number of copies to be printed.
<job name> <job owner>	<nn> SELECTED <nn> PRINTED	3 Press <b>SELECT</b> to print the remaining copies.
<job name> <job owner>	<nn> SELECTED <nn> PRINTED	- Or - Press <b>CANCEL JOB</b> or set the number of copies to zero to delete the remaining copies.

## Paper Handling Menu

**Table 15. Paper Handling Menu**

Item	Value	Description / action
TRAY 1 MODE=	FIRST* CASSETTE	
TRAY 1 TYPE=	PLAIN* PREPRINTD LTRHEAD TRNSPRNCY PREPUNCHED LABELS BOND RECYCLED COLOR CARDSTOCK HEAVY GLOSSY 28# TYPE 1 28# TYPE 2 ENVELOPE	Appears only if TRAY 1 MODE=CASSETTE.
* Default setting.		

**Table 15. Paper Handling Menu (continued)**

Item	Value	Description / action
TRAY 1 SIZE=	LETTER* LEGAL A4 A5 11X17 A3 EXEC JIS B4 JIS B5 JPOSTD COM10 MONARCH C5 DL B5 CUSTOM	Appears only if TRAY 1 MODE=CASSETTE.
TRAY 2 TYPE= TRAY 3 TYPE= TRAY 4 TYPE=	PLAIN* PREPRINTD LTRHEAD TRANSPRNCY (trays 2 and 3 only) PREPUNCHED BOND RECYCLED COLOR GLOSSY 28# TYPE 1 28# TYPE 2	The TRAY 4 TYPE= option appears only if the 2,000-sheet input unit is properly installed.
PAPER DEST=	TOP OUTPUT BIN* LEFT OUTPUT BIN STACKER OUTBIN SEPARATOR BIN MAILBOX 1 MAILBOX 2 MAILBOX 3 MAILBOX 4 MAILBOX 5 MAILBOX 6 MAILBOX 7 MAILBOX 8	The STACKER OUTBIN, SEPARATOR BIN, and MAILBOX options appear only if the multi-bin mailbox is installed and configured for the appropriate mode.
DUPLEX=	OFF* ON	Appears only if a duplexer is properly installed.
BINDING=	LONG EDGE* SHORT EDGE	Appears only if DUPLEX= is set to ON.
* Default setting.		

**Table 15. Paper Handling Menu (continued)**

Item	Value	Description / action
MANUAL FEED=	OFF* ON	Allows the user to feed media into the printer by hand rather than automatically from an input tray. The user can select manual feed instead of automatic input tray as the default for the paper source. If MANUAL FEED = ON and an input tray is not selected, then manual feed is selected.
OVERRIDE A4 WITH LETTER=	NO* YES	Enabling this option prints A4-sized documents on letter-sized media (if letter is the default size), or it prints letter-sized documents on A4-sized media (if A4 is the default size). However, if an input tray is configured for the size you want to override, then the printer prints on the correct size of media regardless of the override setting.
AUTO PAPER OVERRIDE=	OFF* ON	<p>Selects the media the job prints on if the requested media is not found.</p> <p>If ON is selected, the printer displays TRAY &lt;x&gt; LOAD &lt;type&gt; &lt;size&gt;. After a delay the printer automatically prints on plain paper of the default media size. The delay time can be changed through HP JetAdmin software.</p> <p>If OFF is selected, the printer displays TRAY &lt;x&gt; LOAD &lt;type&gt; &lt;size&gt; until it detects the requested media type and size or <b>Go</b> is pressed.</p>
* Default setting.		

## Configuration Menu

**Table 16. Configuration Menu**

Item	Value	Description / action
POWERSAVE=	30 MIN 1 HOUR* 2 HOURS 3 HOURS 10 SEC	The 10-second setting is for service personnel use.
PERSONALITY=	AUTO* PCL PS	Allows the user to determine which personality will be the default for the printer. When AUTO is selected, the printer will determine which personality to use for each print job. <b>Note:</b> PCL support is not available at initial product introduction.
CLEARABLE WARNINGS=	ON* JOB	Determines the amount of time that a clearable warning is displayed on the printer control panel. If set to ON, then clearable warnings are displayed until <b>Go</b> is pressed. If set to JOB, then clearable warnings are displayed until the end of the print job.
TONER LOW=	CONTINUE* STOP	Determines the printer response to consumable low and out messages (including TONER LOW, TRANSFER KIT OUT, FUSER LIFE OUT, and DRUM LIFE LOW).  If set to CONTINUE, clear the message by pressing <b>Go</b> . If set to STOP, clear the message by replacing the consumable.
PRINT PS ERRORS=	OFF* ON	If the PostScript interpreter detects illegal commands, the job is canceled. If ON, an error page prints. If OFF, there is no indication that an error occurred.
INITIALIZE DISK	None	Appears only if the appropriate printer hard disk is installed.  Press <b>SELECT</b> to initialize.
* Default setting.		

## Printing Menu

**Table 17. Printing Menu**

Item	Value	Description / action
COPIES=	1* ... 999	Sets the number of uncollated copies to be sent if the number of copies is not defined by the print job.
PAPER=	LETTER* LEGAL A4 EXEC A5 11X17 A3 JIS B4 JIS B5 JPOSTD	Sets the default media size. The default media size is used for jobs that do not include media size commands, or when the requested media size is not installed in the printer.
ENVELOPE=	COM10 MONARCH C5 DL B5	ENVELOPE is not a separate item. The printer control panel display switches when - VALUE + gets to envelope sizes.
ORIENTATION=	PORTRAIT* LANDSCAPE	
FORM LENGTH=	5 ... 60* ... 128 LINES	
PCL FONT SOURCE=	SOFT INTERNAL* SLOT n (n = 1,2,3,4)	Sets the default font source to look in first for the requested fonts. Soft fonts are selected first, DIMM fonts second, and internal fonts third if all are installed.
PCL FONT NUMBER=	0 (Courier)* ... 999	
PCL PITCH=	0.44 ... 10* ... 99.99	Appears only if the selected font is a fixed-spaced contour font.
PCL POINT SIZE=	4.00 ... 12* ... 999.75	Appears only if the selected font is a proportional-spaced contour font.
* Default setting.		

**Table 17. Printing Menu (continued)**

Item	Value	Description / action
PCL SYMBOL SET=	PC-8* ROMAN-8 ISO L1 ISO L2 ISO L5 ISO L6 PC-775 PC-8 DN PC-850 PC-852 PC-8TK PC-1004 WIN L1 WIN L2 WIN L5 WINBALT DESKTOP PS TEXT LEGAL ISO-4 ISO-6 ISO-11 ISO-15 ISO-16 ISO-17 ISO-21 ISO-60 ISO-69 WIN 3.0 MC TEXT	Default symbol set mapping. Used only for jobs that do not include symbol set selection commands.
COURIER=	REGULAR* DARK	DARK emulates the heavier Courier font of the HP LaserJet III printer. REGULAR is the lighter and more accurate Courier font used since the HP LaserJet 4 printer and in books and magazines.
WIDE A4=	NO* YES	Allows the user to change the printable area of A4-sized media so that eighty 10-pitch characters can be printed on one line. The printer will print past the normal 5-mm boundaries on the sides of the page. This setting is useful if printing files formatted for letter-sized media on A4-sized media.
APPEND CR TO LF=	NO* YES	These are control characters identified in ASCII to control the cursor (which is the current printing position). LF (line feed) moves the cursor down 1 row without changing the column position. CR (carriage return) moves the cursor back to column 1 without moving it down a row.
* Default setting.		

## I/O Menu

If an EIO card is installed, an additional EIO menu will appear.

**Table 18. I/O Menu**

Item	Value	Description / action
I/O TIMEOUT=	5 ... 30* ... 300	Period of time that the printer will wait without seeing data before considering the job complete and printing it. Does not have an effect for jobs with end-of-job markers.
PARALLEL ADV FUNCTIONS=	ON* OFF	Forces parallel port to compatibility mode which can be more reliable in some cases, but will not allow the printer status to be sent to the host computer.
* Default setting.		

## Resets Menu

**Table 19. Resets Menu**

Item	Value	Description / action
FACTORY DEFAULT RESET	None	Resets menus to the factory settings. I/O Menu and Color Adjust Menu values do not change.
RESET ACTIVE I/O	None	Resets I/O to known state.
RESET ALL I/O	None	Used to clear I/O problems.
RESET TRANSFER LIFE COUNT	None	Used to indicate that a new transfer kit has been installed.
RESET FUSER LIFE COUNT	None	Used to indicate that a new fuser kit has been installed.



## Color Adjust Menu

**Table 20. Color Adjust Menu**

Item	Value	Description / action
PRINT TEST PAGE	None	See page 414 for information on using this menu.
BLACK SMOOTH VALUE=	-6 ... 0 ... +6	
CYAN SMOOTH VALUE=	-6 ... 0 ... +6	
MAGENTA SMOOTH VALUE=	-6 ... 0 ... +6	
YELLOW SMOOTH VALUE=	-6 ... 0 ... +6	
BLACK DETAIL VALUE=	-6 ... 0 ... +6	
CYAN DETAIL VALUE=	-6 ... 0 ... +6	
MAGENTA DETAIL VALUE=	-6 ... 0 ... +6	
YELLOW DETAIL VALUE=	-6 ... 0 ... +6	

## Service Mode Menu

The Service Mode Menu can be entered only by pressing the left side of the **- ITEM** and the **- VALUE** keys at the same time. For more information on using the Service Mode Menu, see page 365.

- NVRAM SETTING menu is provided to replace values that might be lost when a formatter board or control board is replaced in the field.
- FORMATTER DIAGNOSTICS menu is provided for manufacturing and field service personnel to perform specific diagnostic tests on the formatter board and its related components.
  - Service personnel can pinpoint problem areas on the formatter board for replacement or for tracking defects.
  - The operator can choose which tests are enabled and disabled during execution, whether the tests run once or continuously, and whether the test sequence stops upon failure or continues despite failure.
  - A fault log is implemented within formatter diagnostics to record errors for review.
  - Because many of the formatter diagnostic tests are destructive memory tests, a special key sequence is used to enter the mode. A message warns service personnel that the printer is about to perform destructive memory tests.

**Table 21. Service Mode Menu**

Service Mode Menu	Item	Value	Description / action
NVRAM SETTING	SERIAL NUMBER	<xxxxxxxx>	This number is the serial number of the printer.  Press <b>- VALUE +</b> to change the value of the current character. Press <b>SELECT</b> to save the value and move to the next character.
	FORMATTER NUMBER	<xxxxxxxx>	This number is the serial number of the formatter board. Enter the number in the same manner as the serial number of the printer.
	TOTAL PAGE COUNT	<xxxxxxxx>	Total number of pages processed.
	COLOR PAGE COUNT	<xxxxxxxx>	Number of color pages processed.
* Default setting.			

**Table 21. Service Mode Menu (continued)**

Service Mode Menu	Item	Value	Description / action
	DUPLEX COUNT	<xxxxxxxxxxxx>	Number of duplex pages processed.
	TRANSFER LIFE LEFT	<xxxx>	Remaining life left from 0 to 100 percent.
	FUSER LIFE LEFT	<xxxx>	Remaining life left from 0 to 100 percent.
	ENGINE SETTING 1	<xxxxxxxxxxxx>	The registration values of the engine used to align the various color planes. The values are listed on a sticker inside the front of the printer (to the left of the printer control panel and to the right of the front door). Enter these values only when replacing the control board. Enter only 12 characters for each engine setting (0 [zero] to F). The last two digits of the engine setting might change after setting because of varying checksum values. This difference is acceptable.
	ENGINE SETTING 2	<xxxxxxxxxxxx>	See ENGINE SETTING 1.
	CR PAPER SIZE	LETTER* A4	The cold reset (CR) paper size is the default paper size for the country for which the printer is localized. If the NVRAM SETTING menu is used to change the CR PAPER SIZE, the PAPER= setting in the Printing Menu also changes to make the new CR PAPER SIZE the default paper size.
	CLEAR EVENT LOG	NO* YES	Clears the printer event log.
FORMATTER DIAGNOSTICS	EXECUTE TESTS		Press <b>SELECT</b> to enter the FORMATTER DIAGNOSTICS menu. <b>ITEM</b> and <b>- VALUE +</b> do not function until <b>SELECT</b> is pressed. Once the FORMATTER DIAGNOSTICS menu has been entered, <b>MENU</b> moves only between the FORMATTER DIAGNOSTICS and FAULT LOG.
* Default setting.			

**Table 21. Service Mode Menu (continued)**

Service Mode Menu	Item	Value	Description / action
	REPEAT=	NO* YES	
	ON FAULT=	BREAK* CONT PAUSE	<ul style="list-style-type: none"> <li>● When set to BREAK, stops at error and only the printer control panel displays a message.</li> <li>● When set to CONTINUE, does not stop at error, and error is posted only to the fault log.</li> <li>● When set to PAUSE, stops at error and the printer control panel displays a message. Press <b>SELECT</b> to continue. Then, error is also posted to the fault log.</li> </ul>
	ROM CRC=	YES* NO	Firmware ROMs are tested.
	DRAM DIMM=	YES* NO	Installed DIMMs are tested to ensure that they are supported by the formatter board and functioning properly.
	IDE ASIC=	YES* NO	This test ensures the read and write integrity of the formatter IDE ASIC.
	DISK=	YES* NO	Used to verify the integrity of the printer hard disk and the interface between the printer hard disk and the printer. This test also ensures that the printer hard disk buffering and caching are working properly.
	VX ASIC=	YES* NO	This test ensures the read and write integrity of the formatter VX ASIC.
	FAULT LOG	first fault message ... last fault msg	Records all errors that occurred while formatter diagnostics tests were executing. FAULT LOG does not appear until the formatter diagnostics have been run and a failure exists. The fault log is cleared when the printer is turned off.
	POWER OFF TO EXIT		Turn the printer off and on to exit the formatter diagnostics and reset the printer.

\* Default setting.

**Table 21. Service Mode Menu (continued)**

Service Mode Menu	Item	Value	Description / action
PAPER PATH	EXECUTE TEST		Press <b>SELECT</b> to execute tests.
	REPETITIONS	1*...10	
	TRAY 1=	ON* OFF	
	TRAY 2=	ON* OFF	
	TRAY 3=	ON* OFF	
	OUTPUT =	TOP OUTPUT BIN* LEFT OUTPUT BIN	
DEVELOPER MOTOR	REPETITIONS	1* ...10	
	EXECUTE TEST		
DRUM MOTOR	REPETITIONS	1* ...10	
	EXECUTE TEST		
SENSOR MONITOR	EXECUTE TEST	0123456789AB 000000000000	Once EXECUTE TEST is selected, the current value (0 or 1) of each of the 10 sensors is shown on the display on the lower line. The upper line of the display shows digits to be used as an identifier.  See page 368 for information on performing this test and an explanation of what sensors each digits in the upper line of the display represent.
EXIT SERVICE MODE			
* Default setting.			

## Selecting the display language

Use the printer control panel to set the printer to display printer messages and print configuration pages in a variety of supported languages.

- 1 To enter configure language mode, hold down **SELECT** while turning the printer on. When CONFIG LANGUAGE (in English) appears on the printer control panel display for approximately one second, release **SELECT**. Once the printer has restarted, LANGUAGE = ENGLISH appears on the display.

---

### Note

Only **- VALUE +**, **SELECT**, and **Go** are active while the display language is being configured. All other keys are ignored.

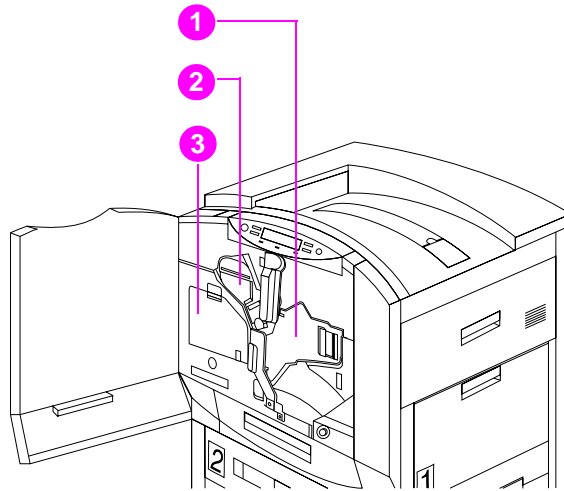
If you press **Go** without selecting a language, the printer brings itself online and all subsequent messages are displayed in English. However, since no display language was selected, the LANGUAGE = ENGLISH message reappears (after the power-on self test) when the printer is turned on again. This message displays every time the printer is turned on until you select a language through the configure language mode.

---

- 2 Press **- VALUE +** until the language you want appears on the display.
- 3 Press **SELECT** to save the selection. An asterisk (\*) appears to the right of the selection. The language selected is the default language until another selection is made by restarting the printer in the configure language mode.
- 4 Press **Go**.
- 5 Turn the printer off and back on.

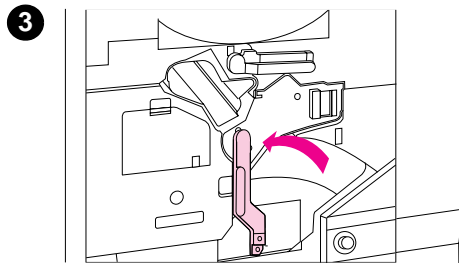
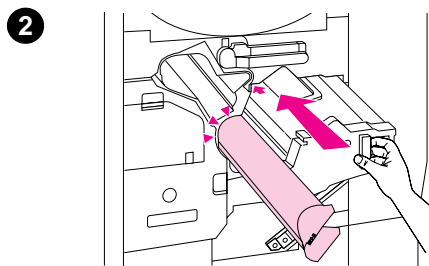
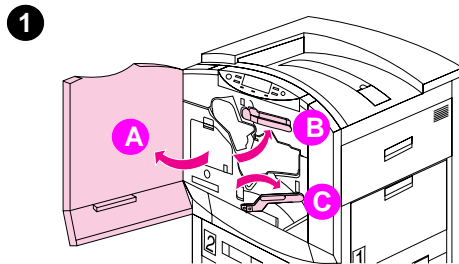
## Installing the consumables

When installing a new printer, install the consumables in the printer in this order:



**Figure 14.** Consumable installation order

- 1 Imaging drum
- 2 Black toner cartridge
- 3 Color toner cartridges



## To install the imaging drum

- 1 Open the front door of the printer (A). Swing the upper (blue) lever to the right (B). Press the white button on the lower (green) lever and swing the lever to the right (C).

---

### CAUTION

There is a cover protecting the drum cylinder. Do not remove this cover or the drum might be damaged; it will come off during the next step.

---

- 2 Push the drum into the printer. The protective cover slides off as the drum enters the printer.
- 3 Swing the lower (green) lever back to the left, making sure it clicks into place.

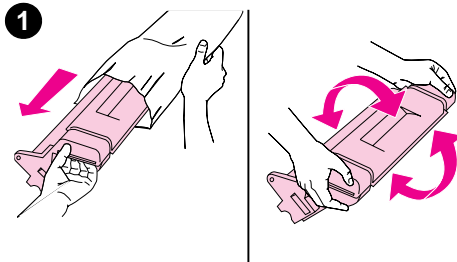
---

### Note

If the lever does not return to its original position, make sure that the imaging drum is all the way in the printer.

---





## To install the black toner cartridge

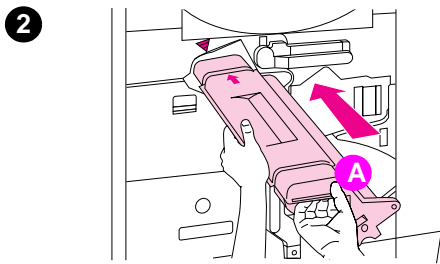
- 1 Remove the black toner cartridge from its packaging and gently rock the cartridge several times to distribute the toner.

---

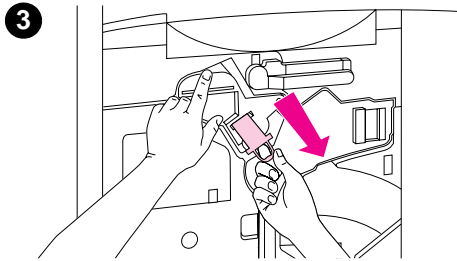
### CAUTION

Do not lift or remove the shutter (A) on the cartridge.

---



- 2 Align the arrow on the top of the cartridge with the arrow at the top of the slot in the printer and slide the cartridge into the printer.



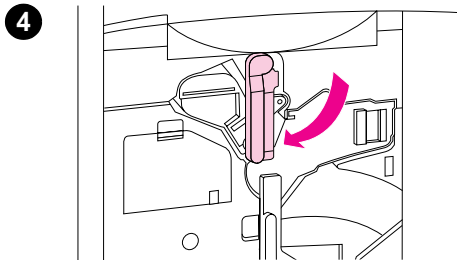
- 3 Place one hand on the cartridge and use the other hand to pull the orange ring and remove the seal. Discard the seal.

---

### Note

If toner gets on fabric, wipe the toner off with a dry cloth and then wash the clothing in cold water. Heat will set toner into fabric.

---



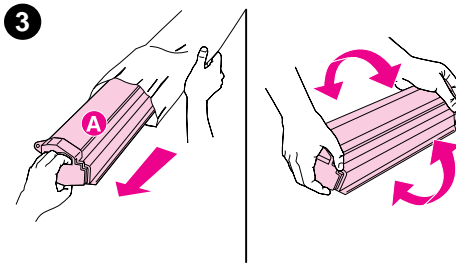
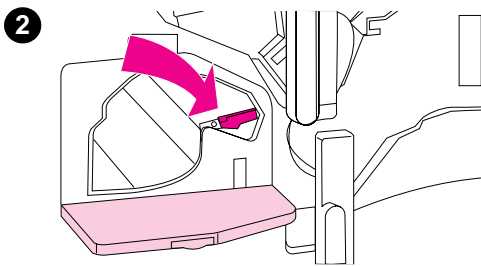
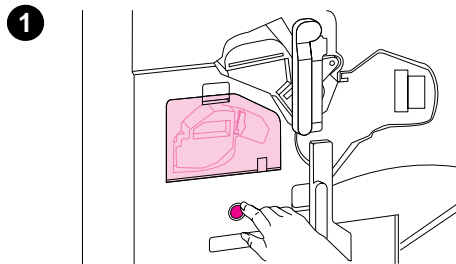
- 4 Swing the upper (blue) lever back to the left.

---

### Note

If the lever does not return to its original position, make sure that the black toner cartridge and the imaging drum are all the way in the printer and that the orange seal was removed from the toner cartridge.

---



## To install the color toner cartridges

- 1 With the printer on, press the blue button beneath the carousel door to turn the carousel to a toner cartridge slot.

### Note

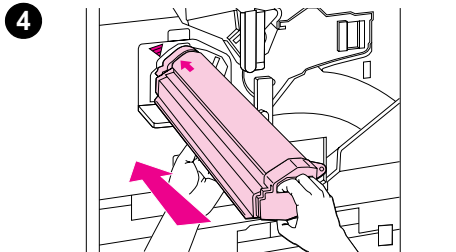
The carousel will not rotate unless all of the following conditions are met (each of these actions engages an interlock switch, which allows the carousel motor to receive power):

- the carousel door is closed
- the imaging drum is installed completely
- the black toner cartridge is installed completely
- the orange seal is removed from the black toner cartridge
- the upper left lever is to the left
- the right upper door is closed

- 2 Open the carousel door, and push the (blue) locking lever to the right.
- 3 Remove the toner cartridge from the package that matches the color of the sticker in the carousel slot from its packaging and gently rock the cartridge several times to distribute the toner.

### CAUTION

Do not lift or remove the shutter (A) on the cartridge.



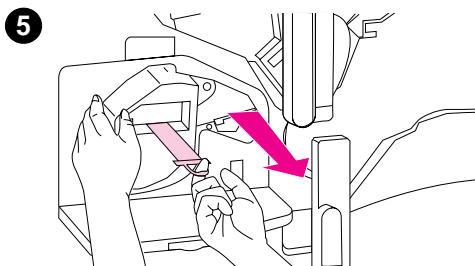
- 4 Align the arrows on the top of the cartridge and at the top of the slot. Slide the cartridge into the printer.

---

**Note**

If the cartridge does not slide completely into the printer, make sure that the color of toner in the cartridge matches the colored sticker on the slot.

---



- 5 Place one hand on the cartridge and use the other hand to pull the orange ring and remove the seal. Discard the seal.

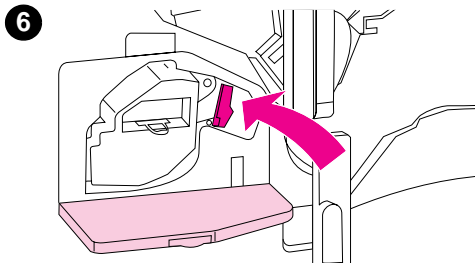
- 6 Push the blue locking lever back to the left and close the carousel door.

---

**Note**

If toner gets on fabric, wipe the toner off with a dry cloth and then wash the clothing in cold water. Heat will set toner into fabric.

---



---

**Note**

If the carousel door does not close, make sure that the blue lever is locked and that the seal has been completely removed from the toner cartridge.

---

- 7 Rotate the carousel to the two remaining slots (by closing the carousel door and pushing the carousel rotation button) and repeat steps 3 through 6 for each color.

- 8 Close the front door.

---

**CAUTION**

To prevent contamination or damage to the printer, do not move the printer after the imaging drum or any of the toner cartridges have been installed.

---

## Configuring input trays

When input trays are configured correctly, the printer prints based on media type and size and automatically uses the correct input tray.

---

### Note

Setting the media type is necessary for best print quality on envelopes, paper greater than 24 up to 28 lb (90 to 105 g/m<sup>2</sup>) bond paper, and paper greater than 28 lb (105 g/m<sup>2</sup>) bond.

---

For example, tray 2 could contain letterhead; tray 3, plain legal-sized paper; and the 2,000-sheet input unit, plain letter-sized paper. If the trays are configured correctly, when you set up a print job you can choose the media type and size in the printer driver, and the printer automatically prints from the correct input tray.

### Selecting the mode for tray 1

Tray 1 has two modes: FIRST mode and CASSETTE mode.

FIRST mode is the default mode for tray 1. In FIRST mode, tray 1 functions as a multipurpose tray. When tray 1 is in FIRST mode, specify the media type and size in the printer driver. The printer looks first for media loaded in tray 1. If the correct width of media is loaded in tray 1, the printer prints from tray 1. If the printer senses that the media in tray 1 is a different size than the media specified in the printer driver, then the printer does not feed the media (to prevent toner residue on subsequent pages).

In CASSETTE mode, tray 1 functions as a regular input tray. When tray 1 is in CASSETTE mode, load media in tray 1 and configure the media type and size in the printer control panel.

- 1 Press **MENU** until PAPER HANDLING MENU appears on the printer control panel display.
- 2 Press **ITEM** until TRAY 1 MODE = appears on the display.
- 3 Press **- VALUE +** until the correct mode appears on the display.
- 4 Press **SELECT** to save the selection. An asterisk (\*) appears to the right of the selection.
- 5 Press **GO** to bring the printer online.

## Configuring media type and size

Configuring the media type is beneficial for several reasons:

- Configuring the media type prevents printing on the wrong (and possibly more expensive) media.
- If a user changes the type of media in an input tray, other users can still print on the correct media.
- The printer automatically adjusts its print speed to accommodate special media (such as card stock, labels, and transparencies). These adjustments give the highest quality output, saving time and resources.

---

### Note

If the media type is not set correctly, then the printer might not print on the correct media or at the correct speed for the media type, which can result in poor print quality or excessively slow printing.

---

- 1 Press **MENU** until PAPER HANDLING MENU appears on the printer control panel display.
- 2 Press **ITEM** until TRAY <number> TYPE = appears on the display.
- 3 Press **- VALUE +** until the correct media type appears on the display.
- 4 Press **SELECT** to save the selection. An asterisk (\*) appears to the right of the selection.

---

### Note

Tray 2, tray 3, and the optional 2,000-sheet input unit automatically sense the media size. To configure the media size for tray 1 in CASSETTE mode, continue with step 5. Otherwise, proceed to step 8.

---

- 5 Press **ITEM** until TRAY 1 SIZE = appears on the printer control panel display.
- 6 Press **- VALUE +** until the media size appears on the display.
- 7 Press **SELECT** to save the selection. An asterisk (\*) appears to the right of the selection.
- 8 Repeat steps 2 through 4 to configure media type in another tray.  
- Or -  
Press **GO** to bring the printer online.

## Verifying the printer is installed correctly

Use the printer control panel to print a configuration page and verify that the printer was installed correctly. Configuration pages include the following information:

- general information about the printer (such as serial number and number of pages since most recent maintenance)
- installed languages
- last three printer events
- memory available and installed dual inline memory modules (DIMMs)
- printer control panel and printer hard disk security
- installed optional equipment (such as a 2,000-sheet input unit, multi-bin mailbox, or duplexer)
- tray configuration
- network configuration

- 1 Press **MENU** until INFORMATION MENU appears on the printer control panel display.
- 2 Press **ITEM** until PRINT CONFIG PAGE appears on the display.
- 3 Press **SELECT** to print the configuration page.

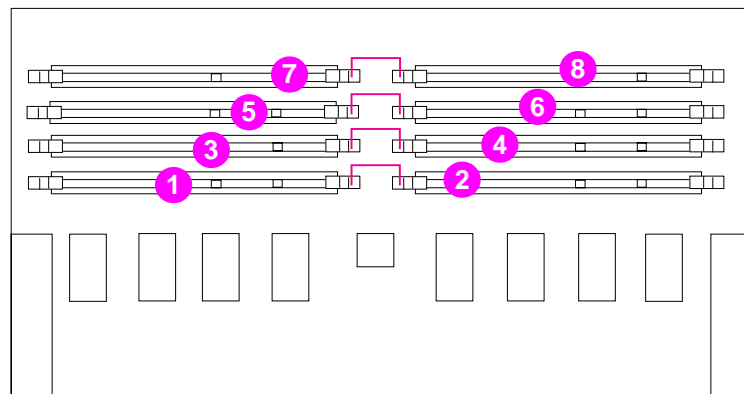
## Verifying DIMM installation

The printer comes with the following amounts of memory installed in slots 1 and 2:

- 16-MB DIMMs in the base and N models
- 32-MB DIMMs in the DN model

In all printer models, slots 3 through 8 are available for additional DIMMs.

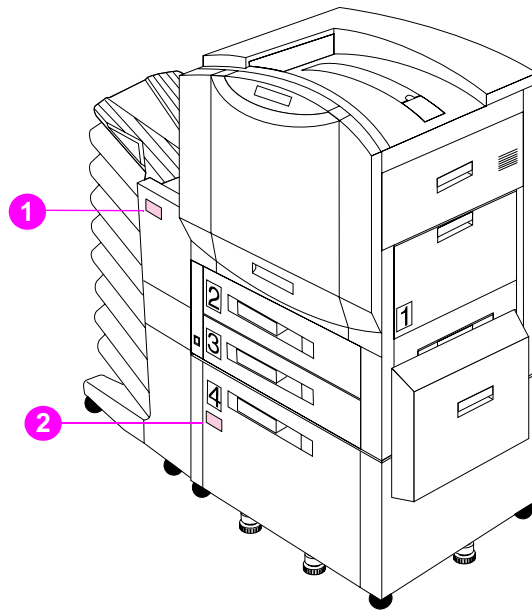
The printer supports ROM and synchronous DRAM DIMMs (dual inline memory modules). EDO (extended data out) or Fast Page Mode DRAM DIMMs are not supported.



**Figure 15.** DIMM slot configuration

- DRAM DIMMs must be installed in synchronized pairs: two DIMMs with the same amount of DRAM are installed in facing left and right slots (such as slots 5 and 6).
- ROM DIMMs need not be installed in a specific configuration. For example, ROM DIMMs can be installed in slots 1 and 3, and slot 2 can be empty. However, ROM DIMMs cannot be installed as pairs (in corresponding left and right slots).

## Paper handling accessory status LEDs



**Figure 16.** Paper handling accessory status LEDs

- 1 Multi-bin mailbox status LED
- 2 2,000-sheet input unit status LED

Use table 22 on page 95 to interpret the status LEDs on the 2,000-sheet input unit and the multi-bin mailbox.



**Table 22. Paper handling accessory status LEDs**

<b>LED</b>	<b>2,000-sheet input unit</b>	<b>Multi-bin mailbox</b>
Solid green	The accessory is on and ready.	The accessory is on and ready.
Solid amber	The accessory is experiencing a hardware malfunction.	The accessory is experiencing a hardware malfunction.
Flashing amber	The accessory has a media jam or a page needs to be removed from the 2,000-sheet input unit, even if the page is not jammed.	The accessory has a media jam or a page needs to be removed from the multi-bin mailbox, even if the page is not jammed.
	The vertical transfer unit (VTU) might be open.	The accessory is not correctly attached to the printer.
Off	The printer might be in Power Save mode. Press <b>Go</b> .	The printer might be in Power Save mode. Press <b>Go</b> .
	The accessory is not receiving power. Check both the power supply and the power cables.	The accessory is not receiving power. Check both the power supply and the power cables.



# 4 Printer maintenance

## Chapter contents

Cleaning procedures . . . . .	99
Cleaning the post charger unit . . . . .	99
Cleaning the density sensor . . . . .	100
Cleaning the transfer charger . . . . .	101
Cleaning the waste toner tray . . . . .	102
Printer consumables . . . . .	104
Replacement frequencies . . . . .	105
Installing consumables . . . . .	106
Toner cartridges . . . . .	106
Transfer kit . . . . .	106
Drum kit . . . . .	110
Fuser kit . . . . .	113

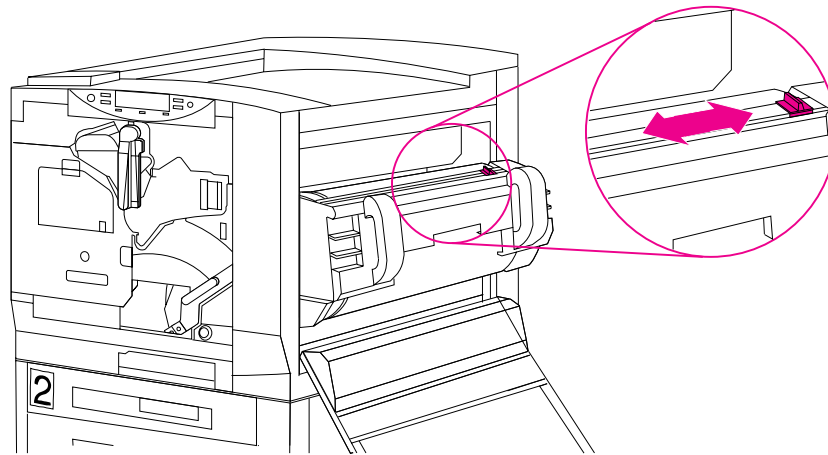


## Cleaning procedures

### Cleaning the post charger unit

Clean the post charger unit on the transfer drum if there are light streaks in halftone areas.

- 1 Open the front door.
- 2 On the lower (green) lever, push the white button and swing the lever to the right.
- 3 Open the right upper door.
- 4 Pull the transfer drum out until it stops.
- 5 Locate the post charger unit cleaner by the transfer drum handle.



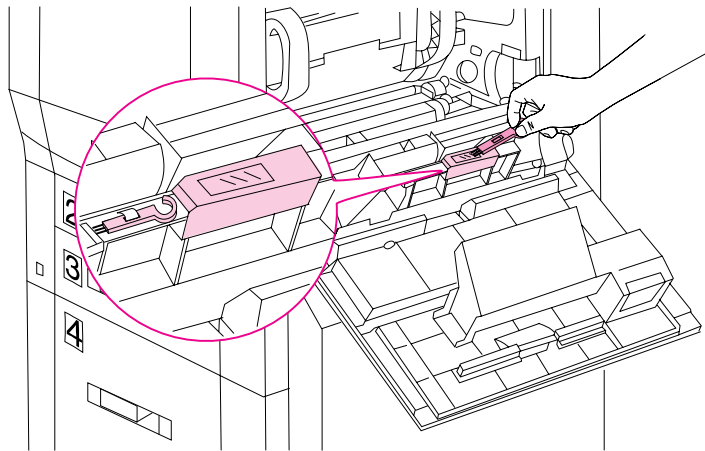
**Figure 17.** Cleaning the post charger unit

- 6 Slide the post charger unit cleaner across the bar several times.
- 7 Push the cleaner back into place, and reinstall the transfer drum.
- 8 Close the right upper door, swing the lower (green) lever to the left, and close the front door of the printer.

## Cleaning the density sensor

Clean the density sensor after replacing the imaging drum, when printer colors are inaccurate, and when the message 54.3 DENSITY SENSOR ERROR CYCLE POWER appears on the printer control panel display.

- 1 Open the right upper door.
- 2 Use the brush located next to the sensor to remove all toner particles from the sensor.



**Figure 18.** Cleaning the density sensor

---

### Note

You can also use a hand wipe to clean the density sensor. To prevent scratches on the sensor, do not use any paper products (such as tissue or paper towels) to clean the sensor.

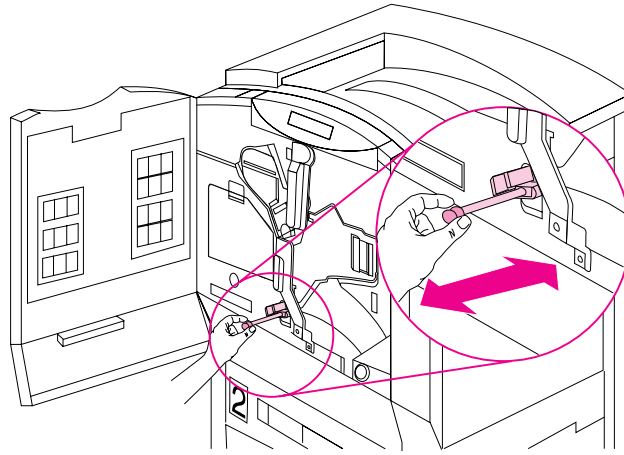
---

- 3 Close the right upper door.

## Cleaning the transfer charger

Clean the transfer charger when irregular wavy patterns appear in solid backgrounds.

- 1 Open the front door.
- 2 Pull the knob out and push it back in.

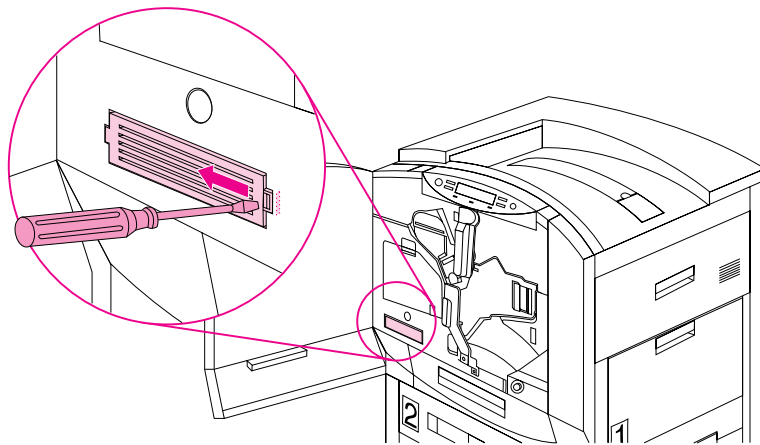


**Figure 19.** Cleaning the transfer charger

## Cleaning the waste toner tray

The waste toner tray will not normally have much toner in it. Clean the waste toner tray before moving the printer to another location or when performing routine maintenance at the customer site.

- 1 Open the front door.
- 2 Remove the waste toner tray cover by releasing the tab on the right side of the cover with a small screwdriver.



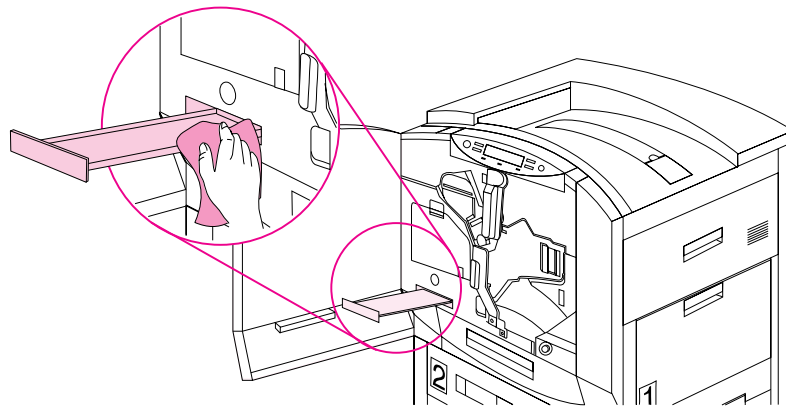
**Figure 20.** Removing the waste toner tray cover



- 3 Remove the waste toner tray.
- 4 Vacuum toner out of the tray, or use a hand wipe to clean the tray if there is a small amount of toner in the tray.

**WARNING!**

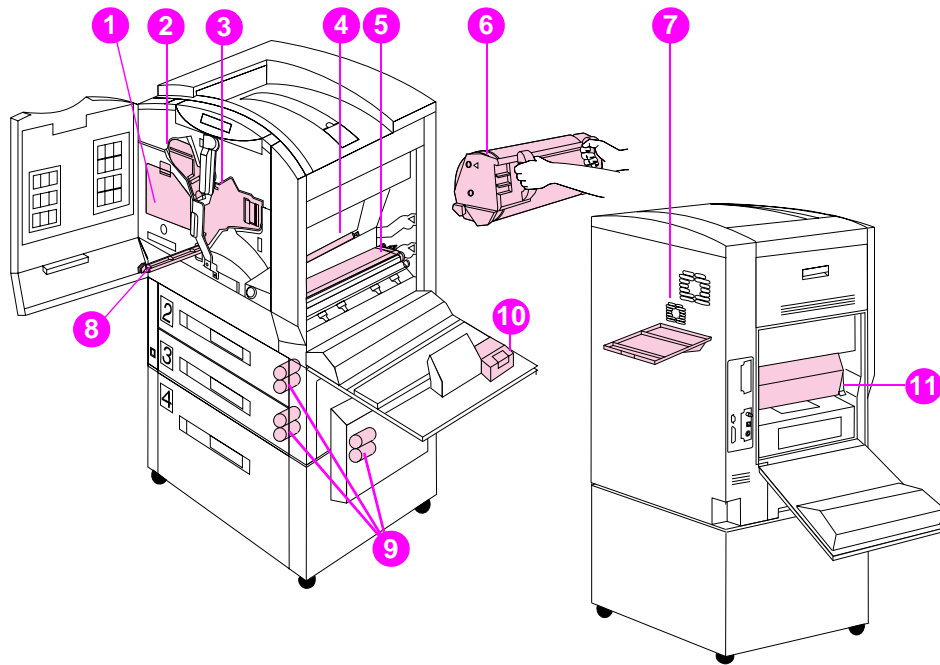
Do not use a regular vacuum to clean up toner. The toner can penetrate the vacuum bag, and toner might be harmful if inhaled.



**Figure 21.** Cleaning the waste toner tray

- 5 Reinstall the waste toner tray and cover, and close the front door.

## Printer consumables



**Figure 22.** Location of consumables in printer

- |   |                        |    |                      |
|---|------------------------|----|----------------------|
| 1 | Color toner cartridges | 7  | Air filters          |
| 2 | Black toner cartridge  | 8  | Transfer charger     |
| 3 | Imaging drum           | 9  | Pick-up/feed rollers |
| 4 | Cleaning roller        | 10 | Charcoal filter      |
| 5 | Transfer belt          | 11 | Fuser                |
| 6 | Transfer drum          |    |                      |

## Replacement frequencies

Table 23 lists the approximate schedule for replacing consumables and the printer messages that appear when each consumable should be replaced. Part numbers for each consumable can be found on page 447. For best print quality output, use HP consumables that have been designed to work together in this printer.

For an explanation of printer control panel messages, see page 316.

HP encourages responsible disposal of HP printer consumables through its printing supplies recycling program. All consumables listed above can be disposed of through the printing supplies recycling program.

**Table 23. Replacement frequencies for printer consumables**

Consumable	Printer message	Page count	Approximate time period <sup>1</sup>
Black toner cartridge	TONER LOW REPLACE BLACK	17,000 pages <sup>2</sup>	2.8 months
Color toner cartridges Cyan Magenta Yellow	TONER LOW REPLACE [color]	8,500 pages <sup>2</sup>	1.4 months
Drum kit Imaging drum Air filters (2) Hand wipe	DRUM LIFE LOW REPLACE DRUM KIT	40,000 black-and-white only pages, or 10,000 color pages	6.7 months black-and-white only pages, or 1.7 months color pages
Transfer kit Transfer drum Transfer belt Transfer charger Cleaning roller Charcoal filter Hand wipe	TRANSFER KIT LOW REPLACE KIT	150,000 black-and-white only pages, or 75,000 color pages	25 months black-and-white only pages, or 12.5 months color pages
Fuser kit (110 Volt) Fuser Paper rollers (6) Hand wipe	FUSER LIFE LOW REPLACE KIT	100,000 pages	16.7 months
Fuser kit (220 Volt) Fuser Paper rollers (6) Hand wipe	FUSER LIFE LOW REPLACE KIT	100,000 pages	16.7 months
<sup>1</sup> Approximate life based on printing 6,000 pages per month. <sup>2</sup> Approximate average letter-size page count based on 5% coverage of individual toner colors. This value can be used to estimate other levels of coverage from 2% to 35%. For example, 5,000 pages at 5% coverage is approximately 2,500 pages at 10% coverage. Estimates made in this manner are only approximate, and usage conditions and print patterns can cause the results to vary.			

## Installing consumables

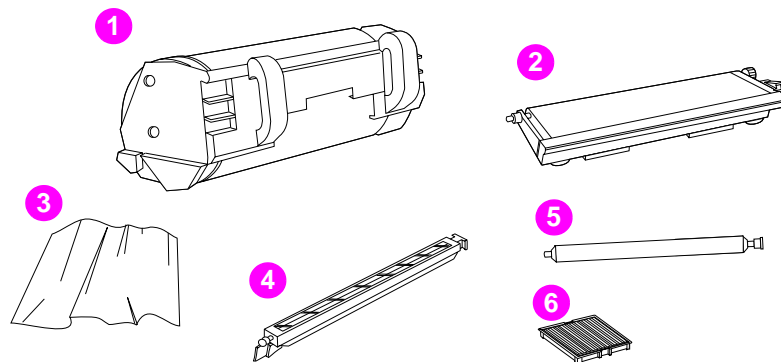
### Toner cartridges

For information on replacing the black and color toner cartridges, see page 87 and page 88.

### Transfer kit

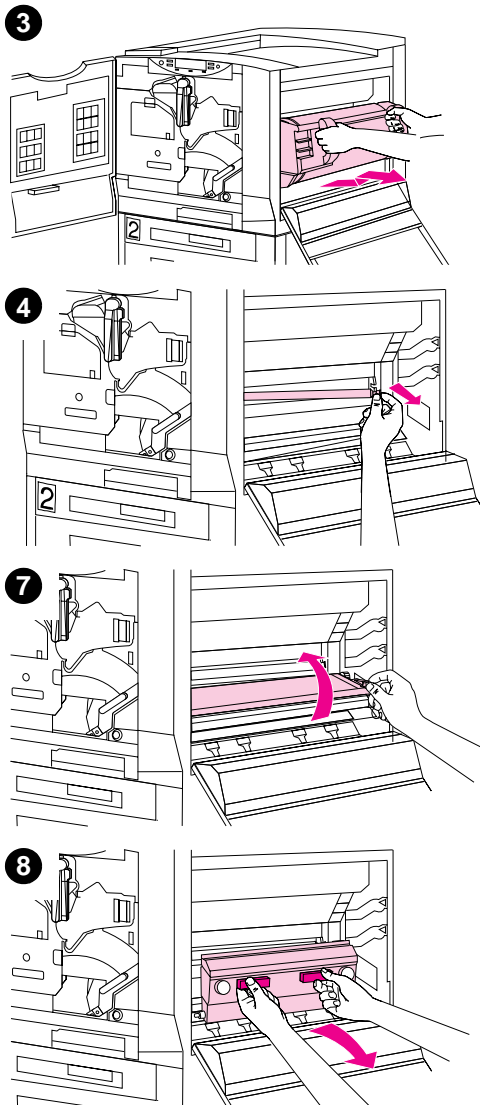
Replace the parts in the transfer kit when the printer control panel displays:

TRANSFER KIT LOW / REPLACE KIT  
TRANSFER KIT OUT / REPLACE KIT



**Figure 23.** Contents of transfer kit

- 1 Transfer drum
- 2 Transfer belt
- 3 Hand wipe
- 4 Transfer charger
- 5 Cleaning roller
- 6 Charcoal filter



## To replace the transfer kit

- 1 Open the front door of the printer.
- 2 Push the white button on the lower (green) lever and swing the lever to the right.
- 3 Open the upper door on the right side of the printer, and remove the transfer drum.
- 4 On the right, back wall of the opening, firmly pull the blue knob to release the right end of the cleaning roller. Lift the roller slowly out and to the right to release the left end.

---

### CAUTION

Do not touch the roller; hold the roller only by the blue knob and left end to avoid print quality problems.

---

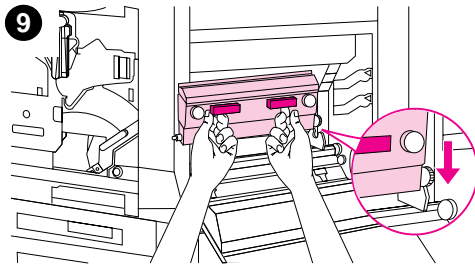
- 5 While holding the new roller by the blue knob, insert the left end into the hole in the left side of the back wall.
- 6 Push the right end into its bracket until it snaps into place.
- 7 Rotate the transfer belt up using the blue lever on the bottom, right side of the printer opening.
- 8 Using the blue handles, lift the belt up and out of the printer.

---

### Note

Do not touch the surface of the transfer belt or poor print quality might result.

---



**9** Replace the belt by resting the ends of the new belt in the notches inside the printer. Place the gear side in the notch first to mesh the gear teeth.

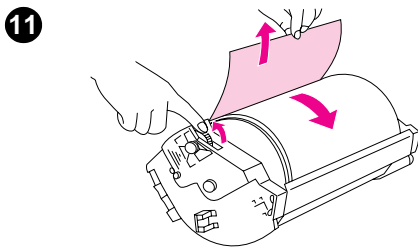
**10** Rotate the belt down into place.

---

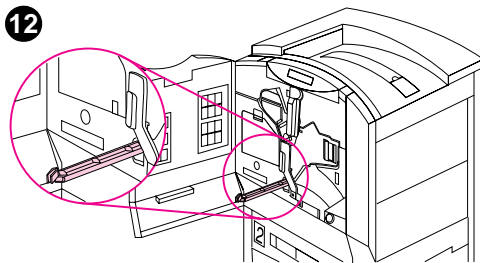
**Note**

Damage to the drum can cause print quality problems. Hold the drum only by the handles.

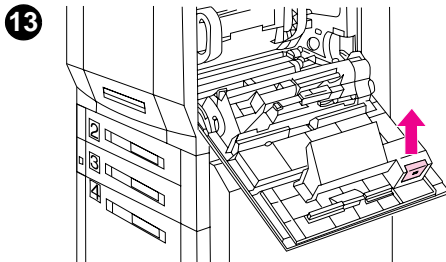
---



**11** Remove the protective sheet covering the new transfer drum by pulling the tab. Discard the sheet. Reinstall the transfer drum.

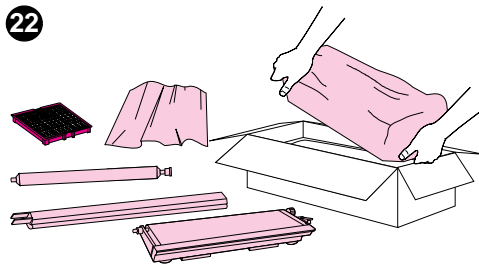
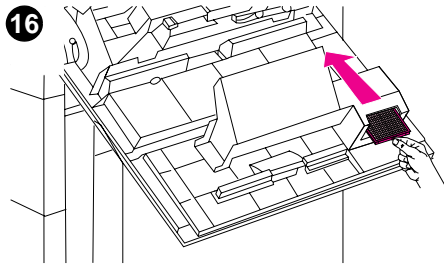


**12** Remove the transfer charger. Remove the new transfer charger from its packaging and while holding the new transfer charger by its blue clip, slide the new transfer charger into the printer until the transfer charger clicks into place.



**13** On the inside of the door, locate the blue filter cover and slide it in the direction of the arrow.

**14** Pull the old filter out of the opening.

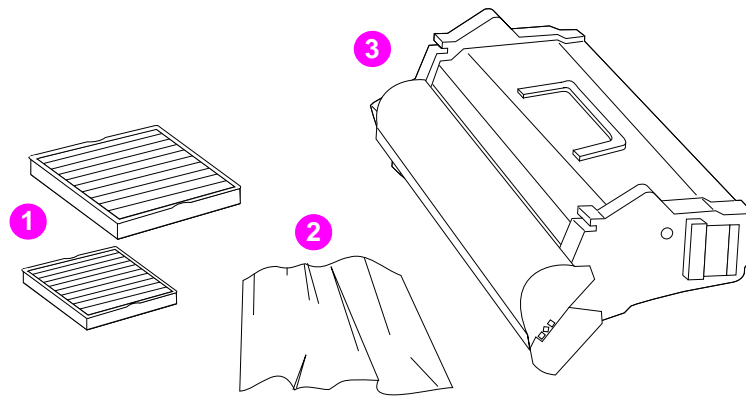


- 15 Hold the new filter by the small handles, and remove the new filter from its packaging.
- 16 Slide the filter in under the guides in the opening and close the blue filter door, making sure it clicks into place.
- 17 Close the upper right door. If the door does not close, the drum might not be all the way in the printer.
- 18 In the front of the printer, swing the lower (green) lever to the left, making sure it clicks into place.
- 19 Close the front door and turn the printer on. The printer control panel should display the message PRESS SELECT IF TRANSFER IS NEW. If it displays the message, go to step 20. If it does not, go to step 21.
- 20 When the printer control panel displays the message, press **SELECT** to bring the printer online and reset the transfer drum life count. Then go to step 22.
- 21 If the printer control panel does not display the message:
  - a. Press **MENU** until RESETS MENU appears on the printer control panel display.
  - b. Press **ITEM** until RESET TRANSFER LIFE COUNT appears.
  - c. Press **SELECT** to reset the transfer drum life count.
  - d. Press **Go** to bring the printer online.
- 22 Place the used parts in the packaging from the new ones. See the included recycling guide for recycling information.

## Drum kit

Replace the parts in the imaging drum kit when the printer control panel displays either of the following messages:

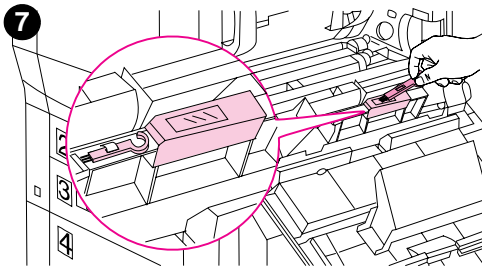
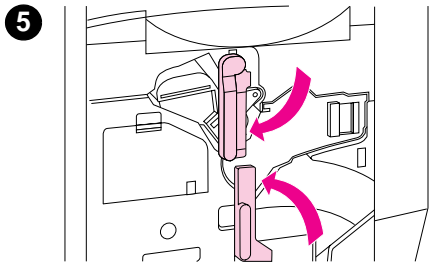
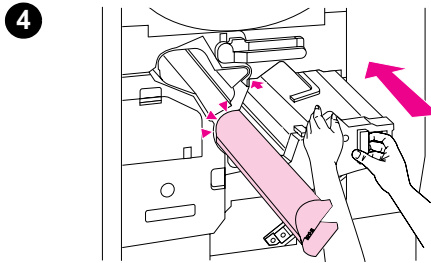
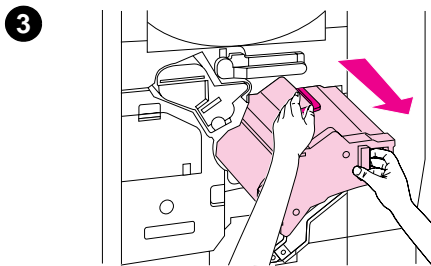
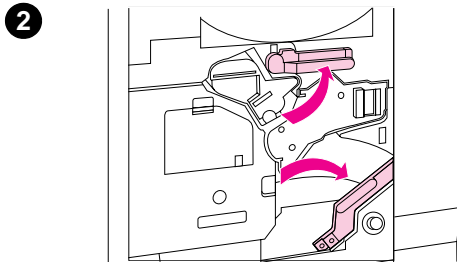
DRUM LIFE LOW / REPLACE DRUM KIT  
DRUM LIFE OUT / REPLACE DRUM KIT  
DRUM ERROR / REPLACE DRUM KIT



**Figure 24.** Contents of drum kit

- 1 Two air filters
- 2 Hand wipe
- 3 Imaging drum cartridge





## To replace the imaging drum and air filters

- 1 Open the front door.
- 2 Swing the upper (blue) lever to the right. Then, press the white button on the lower (green) lever and swing it to the right.
- 3 Pull the drum partway out. Grasp the blue handle on the top of the drum and remove the imaging drum.

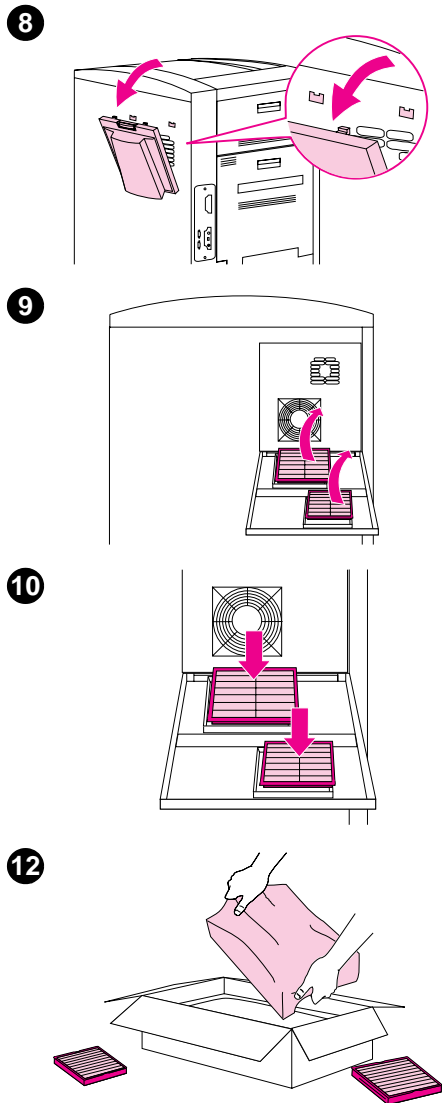
---

### CAUTION

A gray cover protects the new imaging drum. Do not remove this cover; it will come off during the next step.

---

- 4 Line up the guides and push firmly to slide the new drum into the printer. The cover will slide off as the drum enters the printer.
- 5 Swing the upper (blue) lever to the left. Then swing the lower (green) lever to the left, making sure it clicks into place.
- 6 Close the front door and open the upper door on the right side of the printer.
- 7 On the inside of the door, locate the density sensor and the density sensor brush. Use the brush to brush toner particles from the density sensor. Then replace the brush, and close the upper right door.

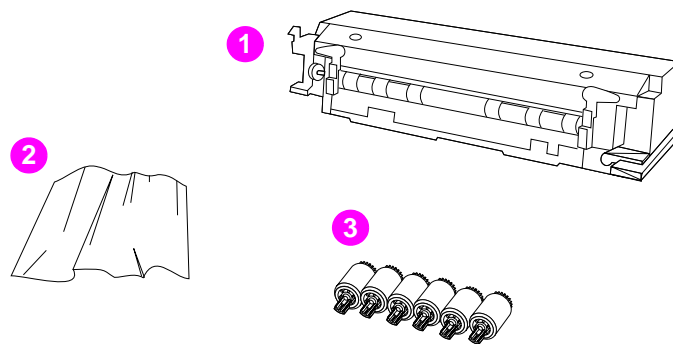


- 8** On the back of the printer, release the two latches on the filter door and lower the door.
- 9** Remove both filters from the door.
- 10** Insert the new filters into their respective locations.
- 11** Close the filter door. If the filter door does not close, make sure the filters are in place. Use the hand wipe to remove toner from your hands.
- 12** Place the used parts in the packaging from the new ones. See the included recycling guide for recycling information.

## Fuser kit

Replace the parts in the fuser kit when the printer control panel displays:

FUSER LIFE LOW / REPLACE KIT  
FUSER LIFE OUT / REPLACE KIT

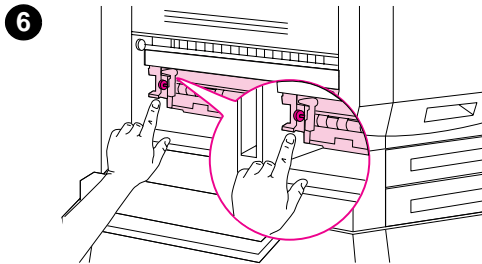
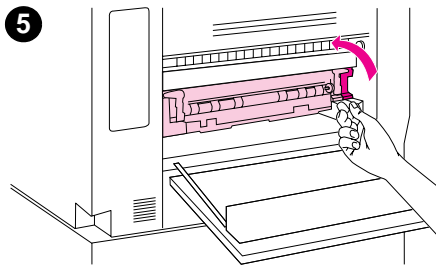
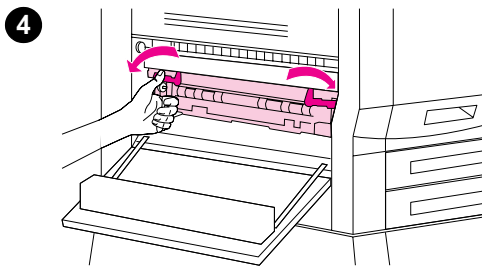
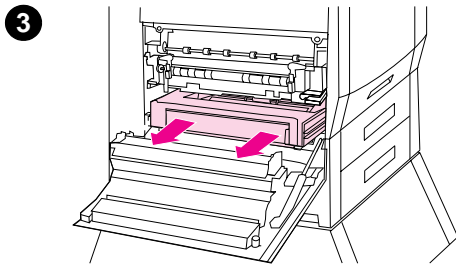


**Figure 25.** Contents of fuser kit

- 1 Fuser
- 2 Hand wipe
- 3 Six paper rollers

**Note** The paper rollers are all the same; any of the rollers can be used in any of the replacement locations.

If you do not have an optional 2,000-sheet input unit, you will need only four of the rollers.

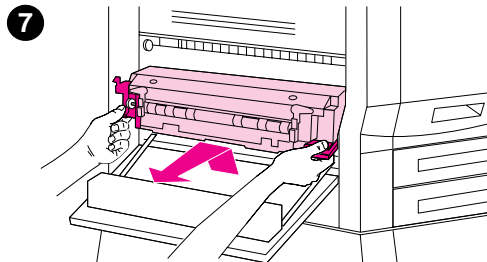


## To replace the fuser

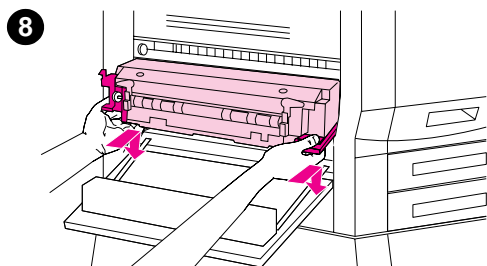
### WARNING!

The fuser is very hot and can cause burns. Turn the printer off and allow the printer to cool for at least 30 minutes before beginning this procedure.

- 1 If an optional multi-bin mailbox is attached to the printer, pull the mailbox away from the printer.
- 2 Open the lower door on the left side of the printer.
- 3 If the printer contains an optional duplexer, press the green tab on the right side of the duplexer and pull the duplexer out of the printer.
- 4 To unlock the fuser, rotate the blue levers down.
- 5 On the right side of the fuser, lift the large green lever to release the fuser springs.
- 6 On the left side of the fuser, rotate the blue gear down two or three times to release the fuser.



**7** Firmly pull the fuser up by the blue tabs on both ends, and then pull the fuser out.



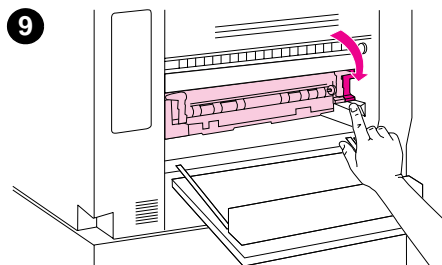
**8** Use the blue tabs to slide the new fuser into the printer along the guides. On the left side of the fuser, rotate the blue gear up two or three times until the fuser drops into place.

---

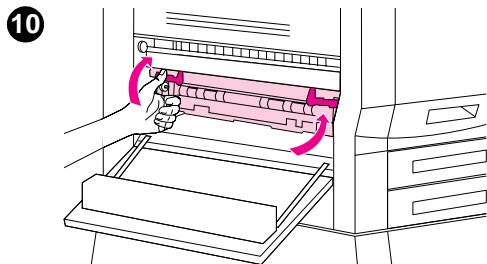
**CAUTION**

Use only the blue tabs to push the fuser into the printer.

---



**9** On the right side of the fuser, push the green lever down.

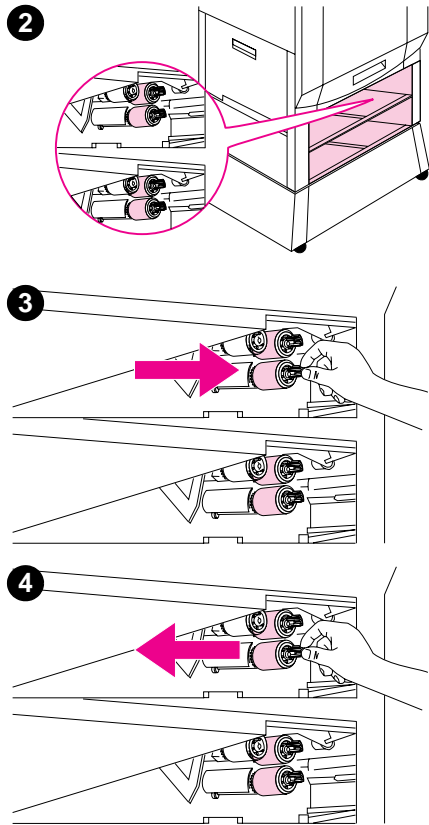


**10** Rotate the blue levers up until they snap into place.

**11** If an optional duplexer was removed from the printer, slide the duplexer back into the printer until it clicks into place.

**12** Close the lower left door.

**13** If an optional multi-bin mailbox is attached to the printer, push the mailbox back toward the printer.



## To replace the rollers

- 1 Remove trays 2 and 3.
- 2 On the inside right of each opening, locate the two paper rollers that are blue on the ends.

---

### Note

The separation rollers that are not blue on the end will not be replaced.

---

- 3 On the end of each roller, pinch together the release lever and handle between two fingers and slide the roller off of its spindle. Set the rollers aside.
- 4 While holding the new roller by its handle, slide the roller onto the spindle until it clicks into place. Repeat this procedure for the other three rollers.
- 5 Replace trays 3 and 2.

---

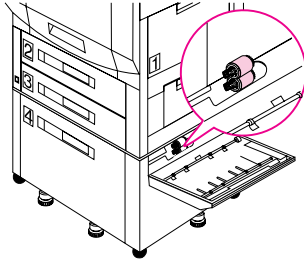
### Note

Trays 2 and 3 are not interchangeable.

---

- 6 If an optional 2,000-sheet input unit is not attached to the printer, proceed to step 9. If a 2,000-sheet input unit is attached, open the vertical transfer door on the right side of the printer.

7



- 7 Locate the two rollers. Remove the rollers (upper roller first) and replace them (lower roller first).

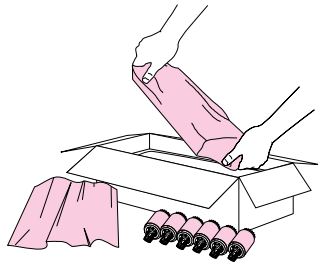
---

**Note**

Press down on the lower roller while replacing the upper one.

---

12



- 8 Close the vertical transfer door and turn the printer on.
- 9 The printer control panel should display the message, PRESS SELECT IF FUSER IS NEW. If it displays the message, go to step 10. If it does not, go to step 11.
- 10 When the printer control panel displays the message, press **SELECT** to bring the printer online and reset the fuser life count. Then go to step 12.
- 11 If the printer control panel does not display the message:
  - a. Press **MENU** until RESETS MENU appears on the printer control panel display.
  - b. Press **ITEM** until RESET FUSER LIFE COUNT appears.
  - c. Press **SELECT** to reset the fuser life count.
  - d. Press **GO** to bring the printer online.
- 12 Place the used parts in the packaging from the new ones. See the included recycling guide for recycling information





# 5 Theory of operation

## Chapter contents

Introduction .....	123
Color theory .....	126
Subtractive color theory .....	126
Subtractive color absorption .....	126
Subtractive color mixing .....	127
Half-toning .....	127
Process colors .....	127
Additive color theory .....	128
Image formation .....	129
Electrostatic latent image formation block .....	131
1. Preconditioning exposure .....	131
2. Primary charging .....	132
3. Laser beam exposure .....	132
Developing block .....	133
4. Development .....	133
Transfer block .....	134
5. Primary transfer .....	134
6. Post charging .....	135
7. Secondary transfer .....	136
8. Separation .....	137
Transfer drum cleaning block .....	138
9. Cleaning roller charging .....	138
10. Transfer drum cleaning .....	139

Imaging drum cleaning block . . . . .	140
11. Imaging drum cleaning . . . . .	140
Fusing block . . . . .	141
12. Fusing . . . . .	141
Consumable detection mechanisms . . . . .	142
Drum kit life detection . . . . .	142
Waste toner level detection . . . . .	142
Transfer kit life detection . . . . .	144
Fuser kit life detection . . . . .	144
Color toner level detection . . . . .	144
Color cartridge sensor . . . . .	145
Color toner lever detection . . . . .	146
Black toner level detection and cartridge detection . .	147
Environment change control . . . . .	147
Color calibration density sensor . . . . .	148
Transfer belt control . . . . .	149
Cleaning roller control . . . . .	150
Carousel control . . . . .	150
Carousel stop solenoid . . . . .	151
Electrical systems . . . . .	152
Power distribution . . . . .	152
Fuser control . . . . .	154
High-voltage power supply circuit . . . . .	155
Mechanical systems . . . . .	157
Laser/scanner . . . . .	157
Motors and heaters . . . . .	159
Carousel motor (M1) . . . . .	160
Drum motor (M2) . . . . .	161
Cartridge motor (M3) . . . . .	162
Main motor (M4) . . . . .	163
Pick-up motor (M5) . . . . .	164
Fan motors (FM1, FM2, and FM3) . . . . .	165

Paper path . . . . .	166
Pick-up/feed . . . . .	167
Automatic overhead transparency detection . . . . .	167
Paper pick-up . . . . .	168
Sensors, switches, clutches, and solenoids . . . . .	172
Switch functionality . . . . .	176
Fusing and delivery unit . . . . .	178
Media jam detection . . . . .	180
EPH controller board . . . . .	180
2,000-sheet input unit . . . . .	180
Power supply . . . . .	180
Sensors, switches, clutches, and motors . . . . .	181
Pick-up and feed system . . . . .	182
Switch functionality . . . . .	183
Lifter operation . . . . .	184
Paper path . . . . .	185
Multi-bin mailbox . . . . .	186
Operating modes . . . . .	186
Configuring operating modes . . . . .	187
Power-on sequence . . . . .	187
Communication link (C-link) cables . . . . .	188
Sensors, switches, motors, and controller board PCA . . . . .	189
Receiving paper . . . . .	190
Delivering paper . . . . .	191
Paper path . . . . .	191
Duplexer . . . . .	192
Printer timing . . . . .	192

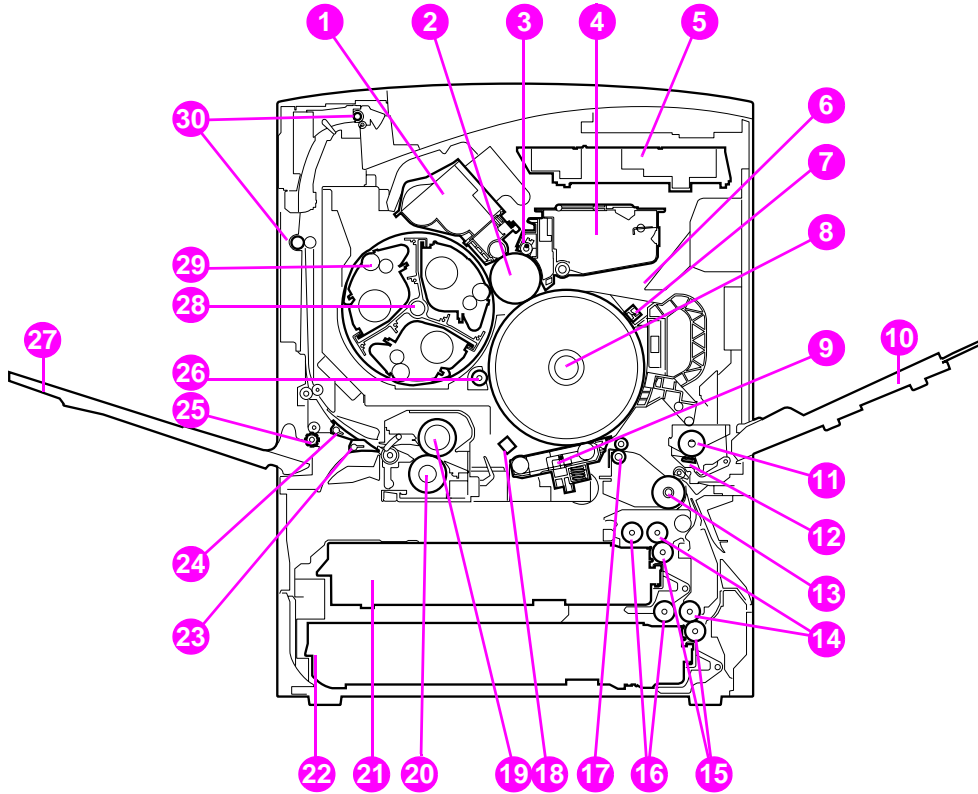


## Introduction

This chapter presents the theory of operation and the functional overview for the printer. It provides the service representative with an understanding of the printing process required to service the printer. This chapter discusses the following:

- Color theory
- Image formation
- Paper path
- Mechanical drive system
- Control board system
- Formatter system
- Power distribution system
- 2,000-sheet input unit
- Multi-bin mailbox

Figure 26 shows a cross-sectional view of the internal components of the printer.



**Figure 26.** Cross-section view of internal components

- |                                       |   |
|---------------------------------------|---|
| <b>1</b> Black toner cartridge        | <b>17</b> Registration roller                       |
| <b>2</b> Imaging drum                 | <b>18</b> Transfer charger                          |
| <b>3</b> Charging roller              | <b>19</b> Upper fusing roller                       |
| <b>4</b> Imaging drum cartridge       | <b>20</b> Lower fusing roller                       |
| <b>5</b> Laser/scanner                | <b>21</b> Tray 2                                    |
| <b>6</b> Preconditioning exposure LED | <b>22</b> Tray 3                                    |
| <b>7</b> Post charging unit           | <b>23</b> Duplexer deflector                        |
| <b>8</b> Transfer drum                | <b>24</b> Left (face-up) output bin deflector       |
| <b>9</b> Transfer belt                | <b>25</b> Left (face-up) output bin delivery roller |
| <b>10</b> Tray 1                      | <b>26</b> Cleaning roller                           |
| <b>11</b> Tray 1 pick-up roller       | <b>27</b> Left (face-up) output bin                 |
| <b>12</b> Separation pad              | <b>28</b> Color toner carousel                      |
| <b>13</b> Feed roller 1               | <b>29</b> Color toner cartridges                    |
| <b>14</b> Feed roller 2               | <b>30</b> Delivery roller(s)                        |
| <b>15</b> Separation rollers          |   |
| <b>16</b> Pick-up rollers             |   |

## Color theory

There are two methods used to create color. The subtractive process (which is used in this printer) and the additive process (which is used in monitors and television).

### Subtractive color theory

The subtractive color theory deals with mixing color pigments (such as those found in toner, ink, and paint) to produce any color. The subtractive primary colors are cyan, yellow, and magenta. Primary colors will produce any color in the spectrum when combined in certain proportions. The subtractive process begins with an external white light reflected from a white surface (for instance, paper). The color components of the light are reflected or absorbed by the paper and toner.

### Subtractive color absorption

Table 24 describes how colors are mixed to produce subtractive colors.

**Table 24. Subtractive color absorption**

<b>Pigment color</b>	<b>Color of absorbed light</b>	<b>Colors of reflected light</b>	<b>Perceived color</b>
Magenta	Green	Blue Red	Magenta
Yellow	Blue	Red Green	Yellow
Cyan	Red	Green Blue	Cyan
None	None	Red Green Blue	White



## Subtractive color mixing

Table 25 describes how mixing equal amounts of subtractive colors produces other colors.

**Table 25. Subtractive color mixing**

Mix equal amounts of...	To produce...
Cyan + Yellow + Magenta	Black
Cyan + Yellow	Green
Yellow + Magenta	Red
Magenta + Cyan	Blue

## Half-toning

Half-toning (also called dithering) is a method used to distribute color pigment to create a full spectrum of color. Because this printer places dots of toner on a page to create an image rather than physically mixing the color (like paint), the dots are distributed in selected patterns. Although they are not physically combined on the page, the eye integrates the dots and the viewer perceives them as a solid color.

## Process colors

The printer does not use half-toning for every application. Any of the four basic colors (cyan, magenta, yellow, or black) can be printed as a solid color. Since red, green, and blue are formed by combining two base colors, they are called process colors. See page 134 for an explanation of how the process colors are created on the transfer drum.

## Additive color theory

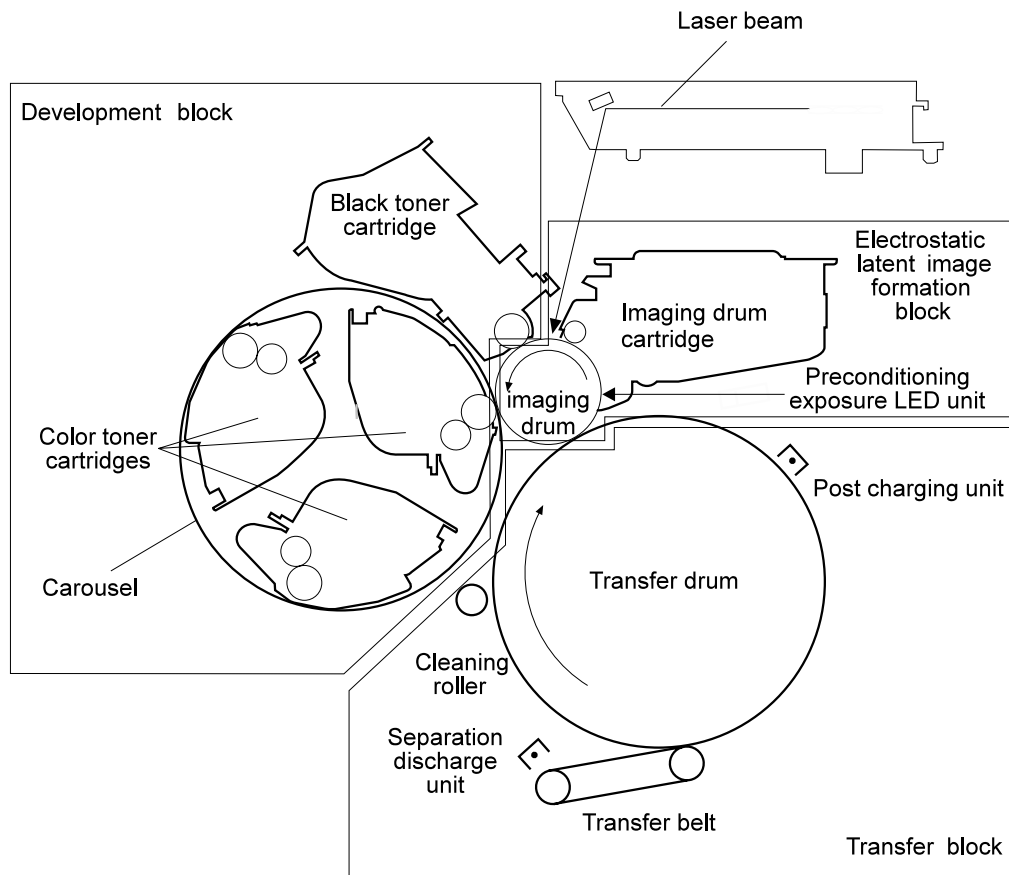
The additive color theory deals with colors that are produced when light sources are mixed. The primary additive colors are red, blue, and green. Adding various levels of these colors, which are generated by a light source (such as a color monitor), produces all other colors. Mixing equal amounts of the additive primary colors produces the colors indicated in table 26.

**Table 26. Additive color mixing**

Mix equal amounts of...	To produce...
Red + Green + Blue	White
Red + Blue	Magenta
Green + Blue	Cyan
Red + Green	Yellow

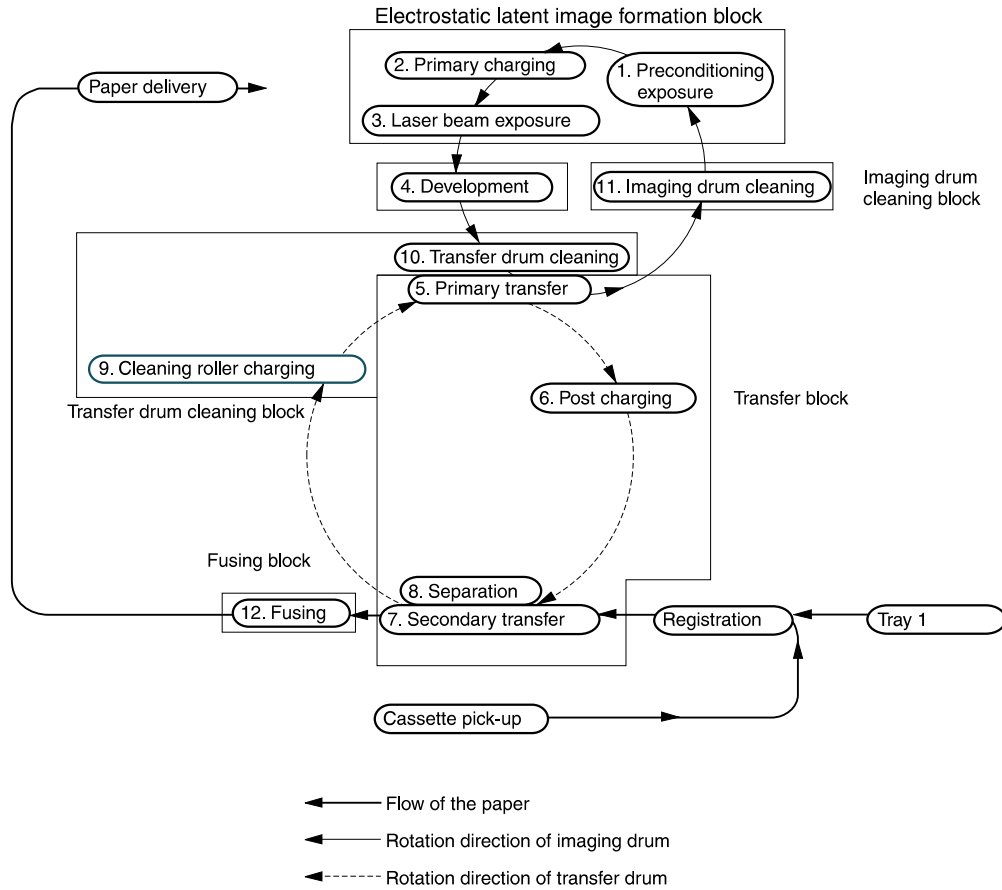
## Image formation

Figure 27 and figure 28 give an overview of the image formation process.



**Figure 27.** Image formation

Figure 28 shows the simultaneous processes of image formation and paper pick-up that occur during the electrostatic latent image formation block.



**Figure 28. Electrostatic latent image formation block**

**Note** In the following sections, the text is numbered to match each of the numbered steps in the process flowchart above.

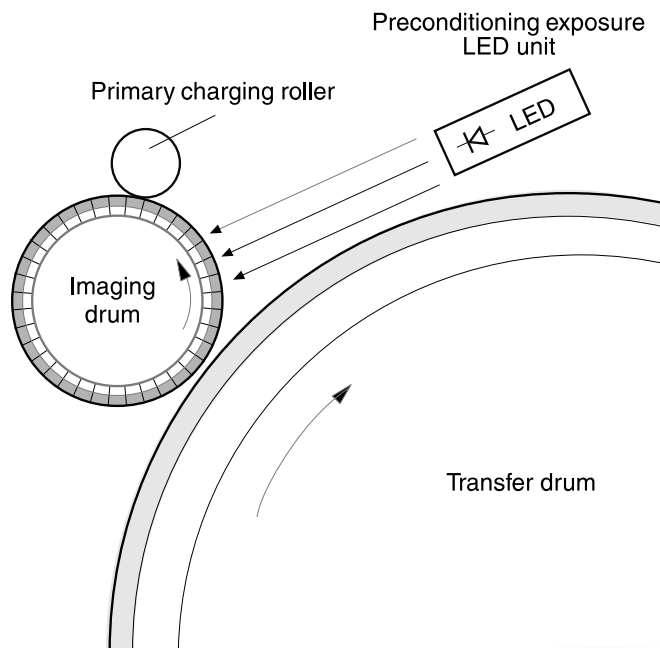
## Electrostatic latent image formation block

One of the differences between color and black-and-white laser imaging is that the color image is created with multiple layers. This printer contains four toner cartridges (cyan, magenta, yellow, and black).

The electrostatic latent image formation block consists of three steps for forming the image on the imaging drum. At the end of the last step, the negative charge on the unexposed area remains while the negative charge on the exposed area is decreased. This potential image on the drum is invisible to the human eye and is called electrostatic latent image.

### 1. Preconditioning exposure

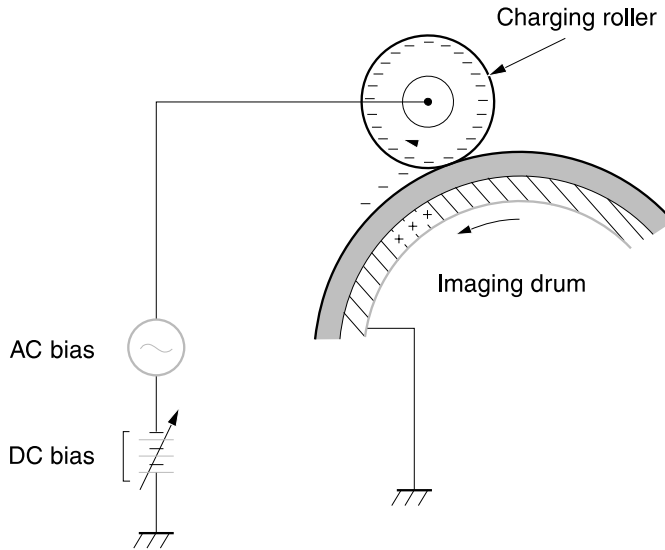
To prepare for primary charging, the preconditioning exposure LED unit removes the residual charge on the imaging drum surface. This helps prevent uneven surface charge on the imaging drum.



**Figure 29.** Preconditioning exposure

## 2. Primary charging

In preparation for the latent image formation, the imaging drum surface is charged so that it has a uniform negative potential. AC and DC bias are applied to the primary charging roller to create uniform negative potential charge on the drum surface.



**Figure 30.** Primary charging of imaging drum

## 3. Laser beam exposure

When the laser beam scans the imaging drum surface, the charge on the exposed area is decreased. This area then forms the electrostatic latent image.

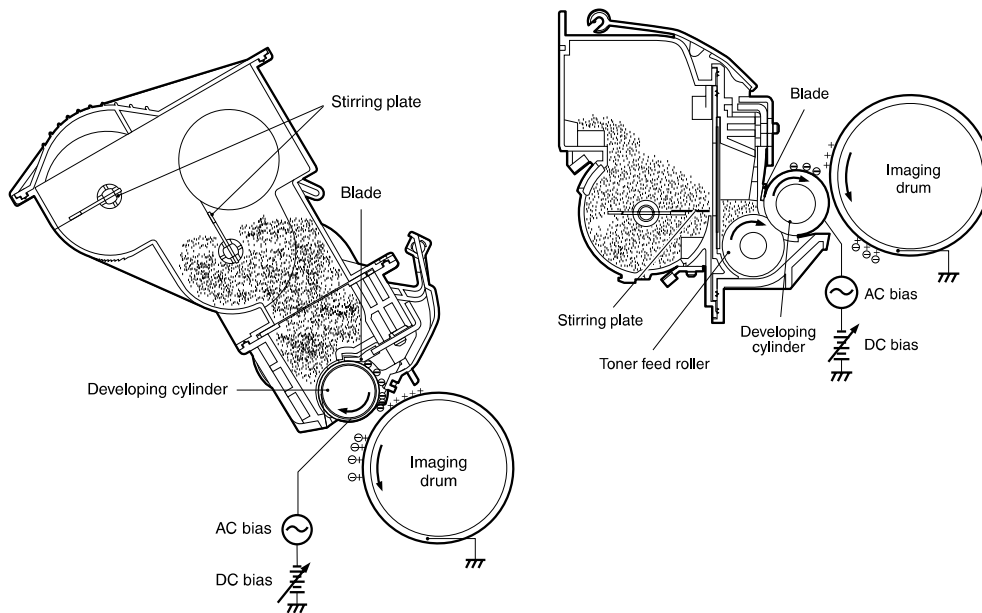
## Developing block

The black toner used in the printer is magnetic single-component toner composed of magnetite and resin. The color toner is non-magnetic single-component toner composed of resin. The toners are given a negative charge when they rub against the developing cylinder and the blade.

### 4. Development

The developing cylinder is biased to create a potential difference with the imaging drum. This bias consists of AC and DC components. The AC component breaks the toner free from the developing cylinder, creating a toner cloud. The DC component drives the toner particles to the imaged region on the imaging drum.

The three color cartridges are brought into contact with the imaging drum when the carousel rotates. The black toner cartridge is set separately, and is always in contact with the imaging drum. When the area on the imaging drum exposed by the laser beam nears the developing cylinder, the charged toner particles move from the developer to the image surface because of the potential differences between the developing cylinder and the exposed imaging drum.



**Figure 31.** Black toner cartridge (left) and color toner cartridge (right) development

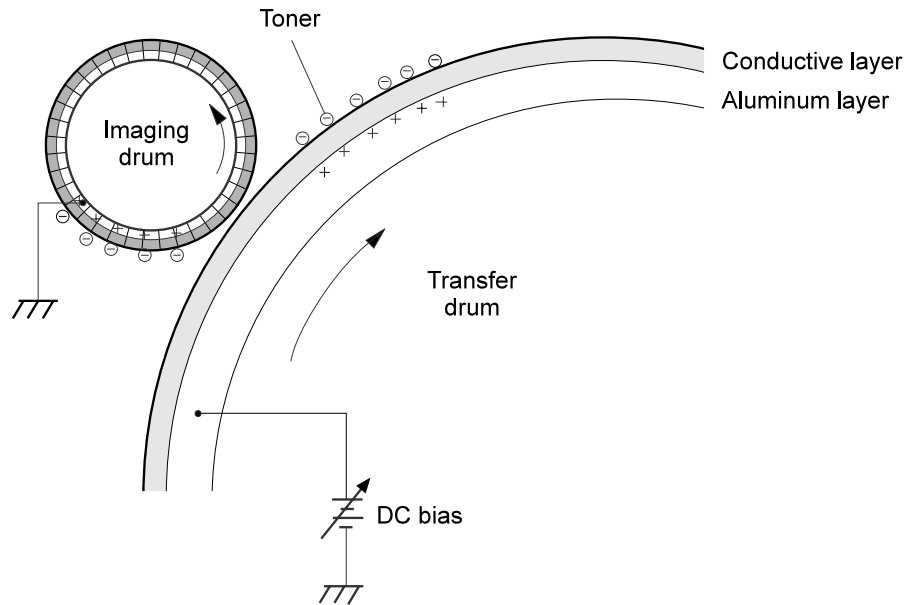
## Transfer block

The image is built up on the transfer drum in layers of toner. The toner is then transferred to the paper. The transfer block includes the transfer of the toner from the imaging drum to the transfer drum, then from the transfer drum to the paper.

### 5. Primary transfer

A positive DC bias is applied to the transfer drum during printing to transfer the toner that is on the imaging drum to the transfer drum. This process occurs in sequence for the four colors (yellow, magenta, cyan, black).

For full-color printing, as the transfer steps proceed for the four colors, the amount of toner with negative charge increases on the transfer drum. As a result, the DC bias must increase to transfer the toner on top of the toner that is already on the transfer drum.



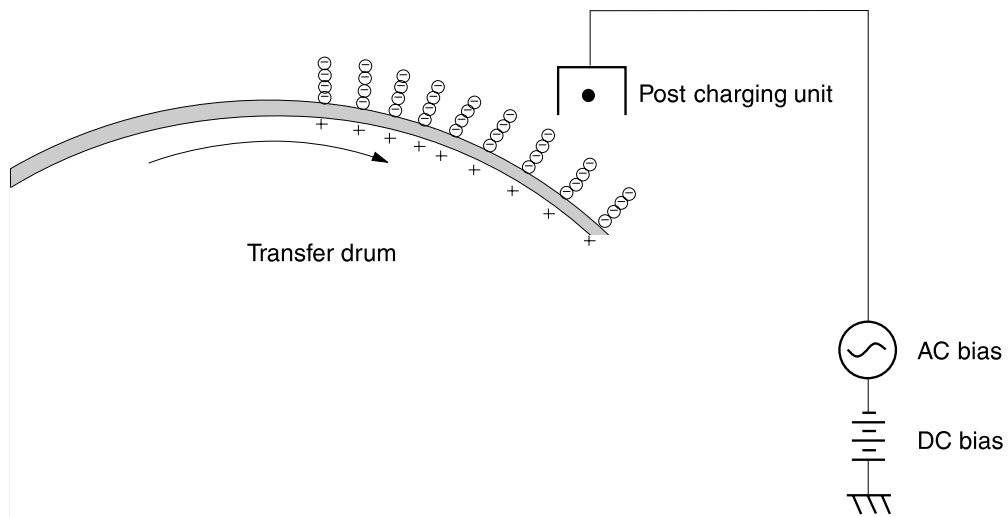
**Figure 32.** Primary transfer



## 6. Post charging

AC and DC bias are applied to the post charging unit to add the appropriate bias to the toner that is on the transfer drum and to increase the efficiency of the secondary transfer.

The post charging unit is turned on during the yellow toner primary transfer as well as after the entire image is formed. During the yellow toner transfer, the negative charge is decreased. A negative bias is applied for the black toner transfer to increase the efficiency of the secondary transfer (the transfer of the toner from the transfer drum to the paper).

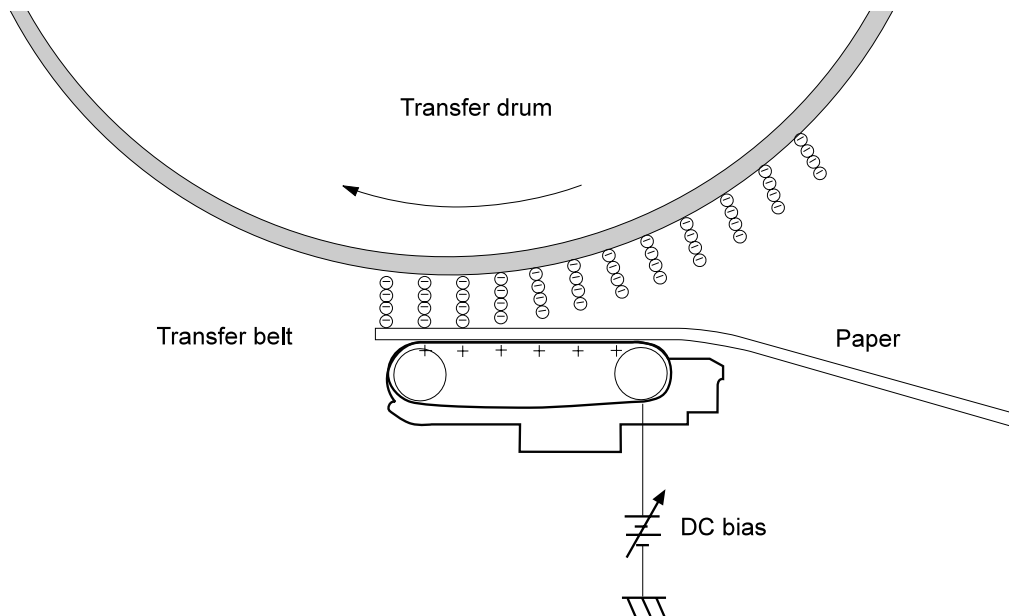


**Figure 33.** Post charging

## 7. Secondary transfer

The paper is pressed against the transfer drum when the transfer belt press clutch (CL4) pushes the transfer belt up to the transfer drum. Positive DC bias is applied to the transfer belt to transfer the toner that is on the transfer drum surface to the paper. The positive DC bias value changes according to the paper type (such as plain, heavy, or overhead transparency) and environmental conditions. Because the transfer belt is highly resistive, the potential bias is reversed between pages to eliminate excessive charge build up on the transfer belt.

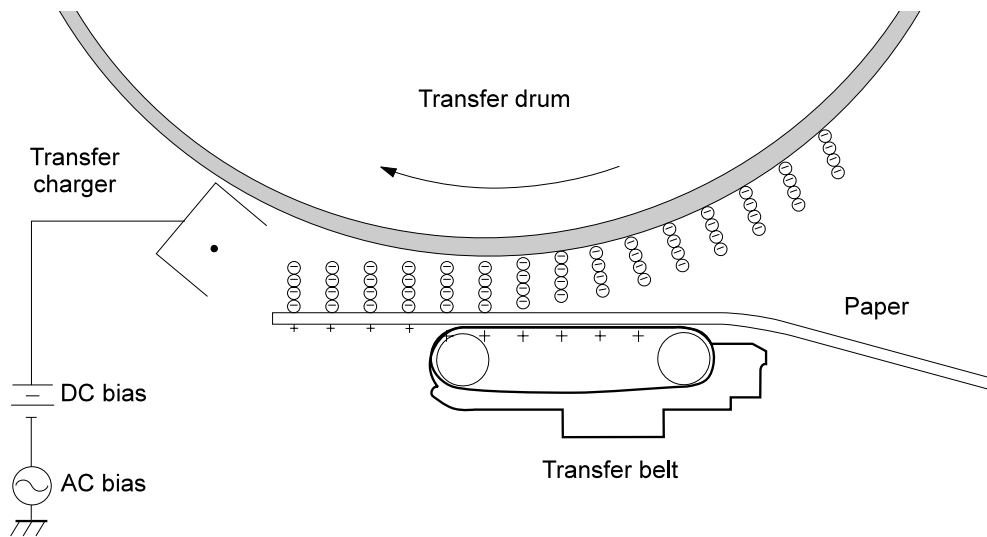
After a jam, negative DC bias is applied to the transfer belt to transfer any residual toner from the transfer belt. The residual toner moves back to the transfer drum, and is then collected in the waste toner case in the imaging drum.



**Figure 34.** Secondary transfer

## 8. Separation

The paper is separated from the transfer drum because of the paper's elasticity. When duplex printing or overhead transparency (OHT) printing is performed, an AC bias is applied to the transfer charger. In high temperature/high humidity conditions, the AC bias is not applied since excessive charge does not build up in high humidity conditions. The AC bias is applied to the transfer charger to prevent discharge between the paper and the transfer belt, which can disrupt the image.



**Figure 35.** Separation

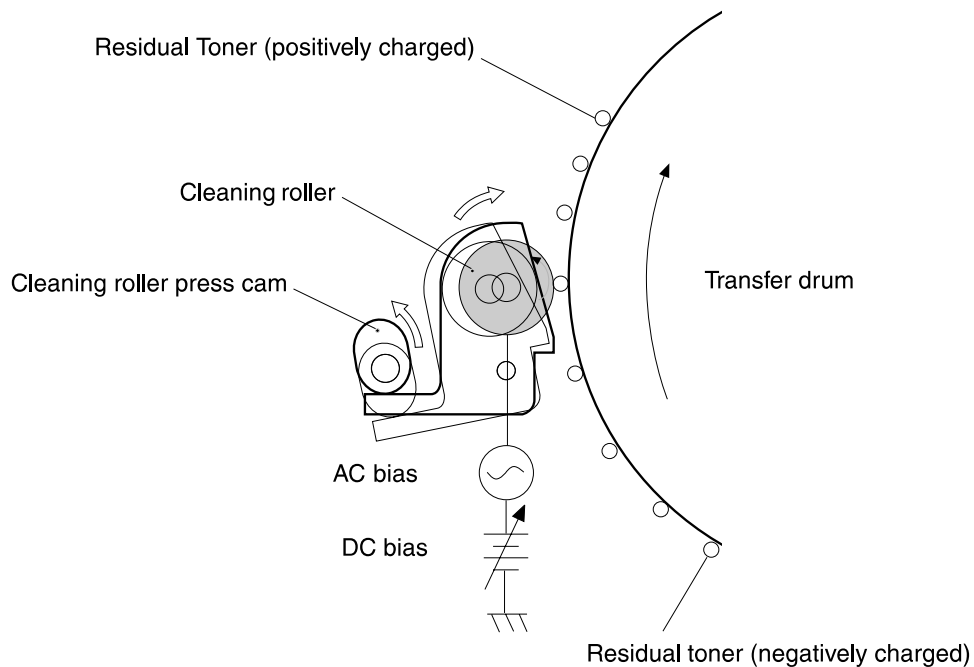
## Transfer drum cleaning block

This block follows two steps to clean the transfer drum. Even though most of the toner is transferred to the paper during secondary transfer, some toner particles remain on the transfer drum surface. This residual toner on the transfer drum is returned to the imaging drum, where it will be moved to the waste toner case.

### 9. Cleaning roller charging

Bias is applied to the cleaning roller so that the residual toner on the transfer drum surface is charged positive. The cleaning roller is usually separated from the transfer drum. However, the cleaning roller can be brought into contact with the transfer drum by the cleaning roller press cam which is activated by the cleaning roller press solenoid (SL1). When contact is made, positive bias is applied to the cleaning roller to charge the toner on the transfer drum surface positive.

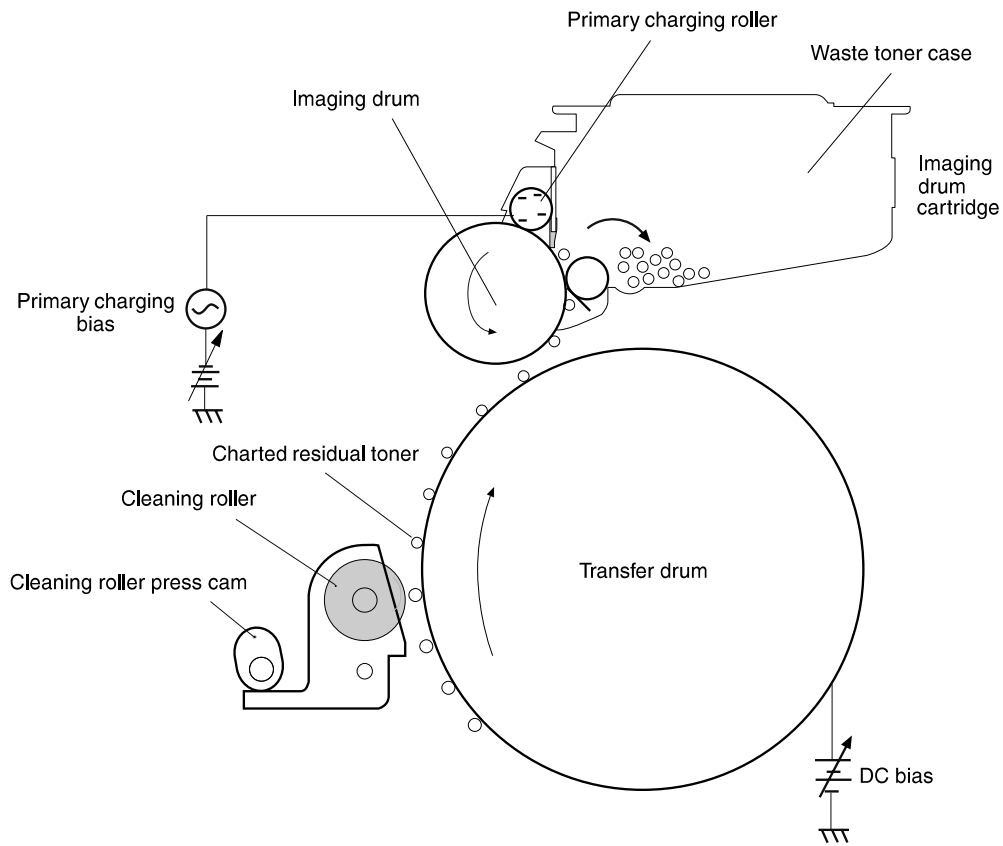
After the charging is complete, the bias is turned off and the cleaning roller press cam separates the cleaning roller from the transfer drum. After printing is complete, negative bias is applied to the cleaning roller to remove the residual toner.



**Figure 36.** Cleaning roller charging

## 10. Transfer drum cleaning

The bias on the imaging drum is negative, and the bias on the transfer drum is positive. Since the charge on the residual toner is made positive by the transfer drum cleaning roller, the toner moves from the transfer drum to the imaging drum, where it will be removed during imaging drum cleaning.



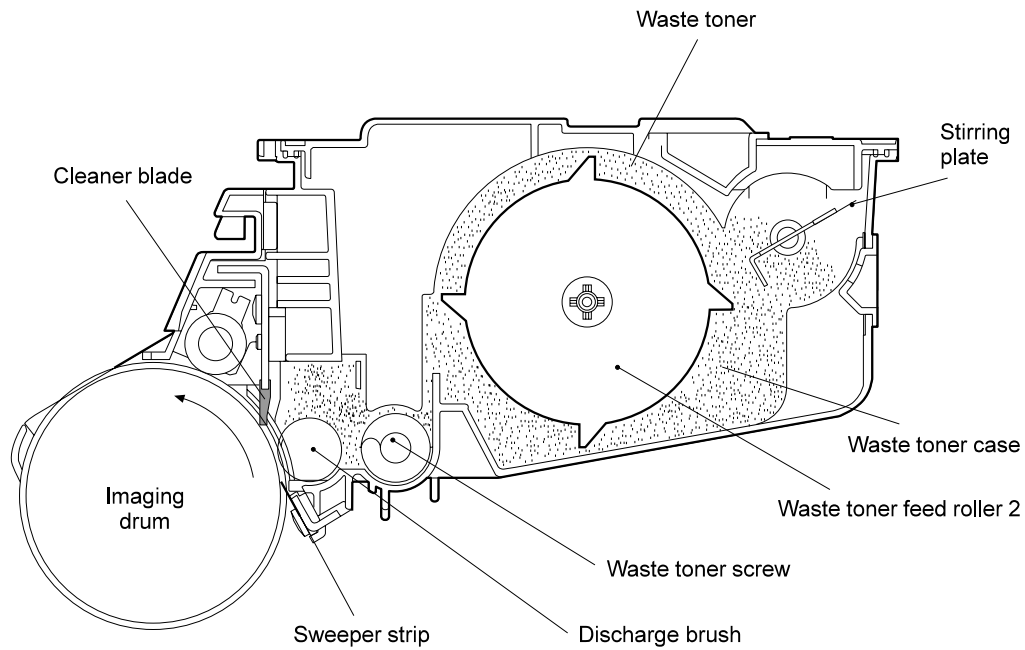
**Figure 37.** Transfer drum cleaning

## Imaging drum cleaning block

In the primary transfer, not all of the toner on the imaging drum is transferred to the transfer drum, leaving some toner on the imaging drum surface. Also, additional toner is placed on the imaging drum surface when the transfer drum is cleaned.

### 11. Imaging drum cleaning

To prepare for the next printing operation, the cleaner blade scrapes the residual toner off the imaging drum surface. The scraped toner particles are trapped with the sweeper strip and collected into the waste toner case.



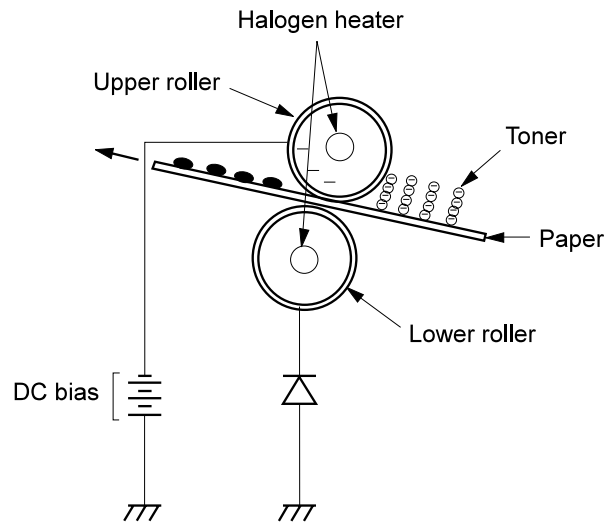
**Figure 38.** Imaging drum cleaning block

## Fusing block

The toner image placed on the paper during transfer adheres to the paper by static electricity, and a light touch will smear the image. During fusing, the four toner colors are melted on the paper to create a permanent image.

### 12. Fusing

The surfaces of the upper and lower fusing rollers are coated with silicone, which has excellent offset prevention performance. The upper fusing roller is charged with a negative DC bias to repel the toner and help prevent the toner on the paper from adhering to the roller.



**Figure 39.** Fusing the toner

## Consumable detection mechanisms

For information on resetting the consumable life counts, see table 19 on page 78.

### Drum kit life detection

The imaging drum cartridge contains a memory device. The number of images printed is written to the imaging drum cartridge memory. The controller board senses the imaging drum life expiration based on the data from the imaging drum cartridge memory. When the image count reaches approximately 35,000 images, DRUM LIFE LOW / REPLACE DRUM KIT is displayed on the printer control panel. This error is also written into the imaging drum cartridge memory and cannot be erased.

The printer is still able to print after the imaging drum life expiration warning. The controller board counts the number of printed images after notification occurs. When the number reaches approximately 40,000 images, the controller board stops the printer and signals DRUM LIFE OUT / REPLACE DRUM KIT. Printing cannot continue until a new imaging drum is installed.

---

**Note**

---

An image is one layer of toner (cyan, magenta, yellow, or black). A full-color page is counted as four images.

### Waste toner level detection

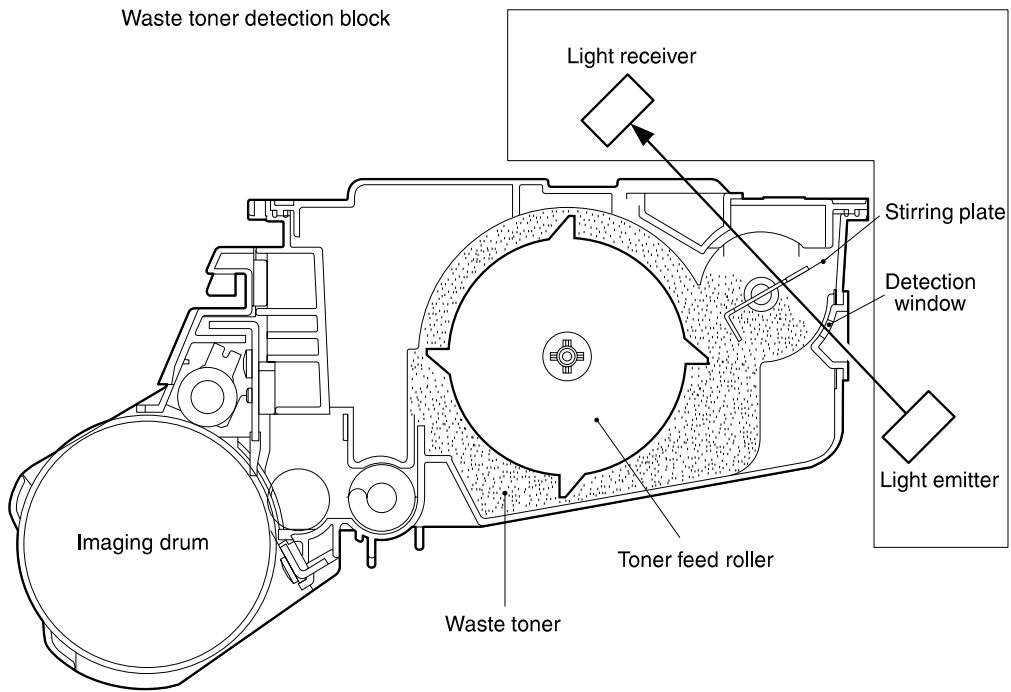
The waste toner detection unit in the printer senses the waste toner level by emitting light into the detection window and passing the light through the imaging drum cartridge when the stirring plate in the drum removes the waste toner around the detection window. The controller board detects the toner level by timing from the moment that the detection window is cleared, to the time the waste toner recovers the window. If the time is shorter than a stored value in the controller board, DRUM ERROR / REPLACE DRUM KIT is reported on the printer control panel. The controller board writes the data into the imaging drum cartridge memory.

The printer is still able to print after the waste toner full warning. The controller board counts the number of printed images after notification occurs. When the number reaches approximately 200 images, the



controller board stops the printer and signals DRUM LIFE OUT / REPLACE DRUM KIT. Printing cannot continue without a new imaging drum being installed.

**Note** If the imaging drum cartridge memory fails, a warning will be displayed on the printer control panel. Printing can continue until the waste toner sensor indicates full.



**Figure 40.** Waste toner level detection

## **Transfer kit life detection**

The transfer kit life is determined by both the page and image counts. The number of images printed is stored in the formatter, and the controller board senses the transfer kit life expiration based upon this data. When the life data reaches 149,000 pages or 299,000 images total, TRANSFER KIT LOW / REPLACE KIT is displayed on the printer control panel. The printer is still able to print after the transfer kit low warning.

The formatter counts the number of printed images after the transfer kit low warning occurs. When the number reaches 150,000 pages or 300,000 images, the controller board signals TRANSFER KIT OUT / REPLACE KIT. End of life behavior is determined by the TONER LOW setting on the printer control panel (see page 75). Printing can continue after the transfer kit out signal, however print quality might be degraded and the number of jams might increase.

Because there is not a memory mechanism in the transfer devices, it is necessary for users and service personnel to reset the transfer count when a new transfer kit is installed. Also if the formatter board is replaced, the transfer count must be reset in the Service menu.

## **Fuser kit life detection**

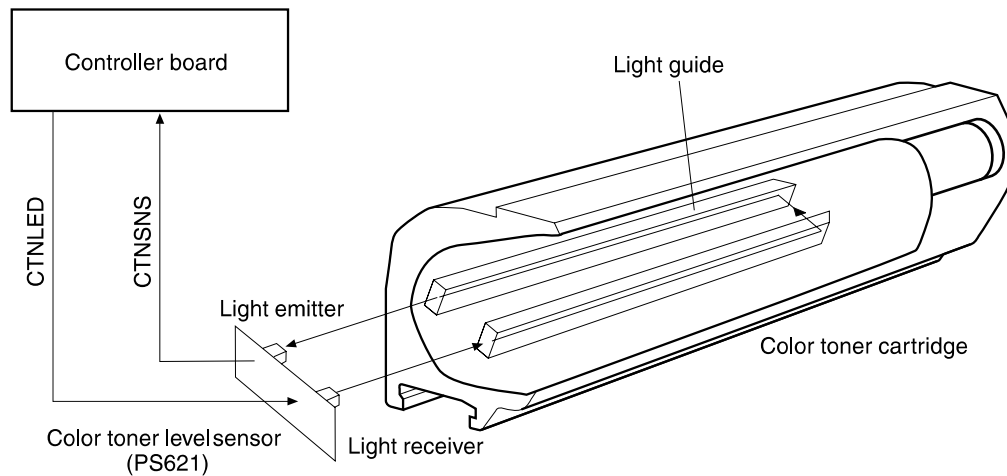
The controller board senses the fuser kit life expiration based upon page count stored in the formatter. When the page count reaches 99,000 pages, FUSER LIFE LOW / REPLACE KIT is displayed on the printer control panel. The printer is still able to print after the fuser kit life expiration warning. The formatter counts the number of printed images after notification occurs. When the number reaches the 100,000 pages, the controller board signals FUSER LIFE OUT / REPLACE KIT. End of life behavior is determined by the TONER LOW setting on the printer control panel (see page 75). Printing can continue after the fuser life out signal, but print quality might be degraded.

## **Color toner level detection**

The color toner level sensor (PS621) detects the toner level in the color toner cartridge. PS621 consists of a light emitter and a light receiver. The light from the light emitter enters the detection window by the light guide facing the outside of the toner cartridge. The light entering the detection window passes through the inside of the cartridge. Then the light guide by the stirring plate cleans the toner

around the detection window. The light receiver of PS621 detects the toner. After PS621 detects light, the controller board notes the time until light can no longer pass through the detection window.

The controller board signals the formatter that the color toner cartridge has no toner if the time the light passes through the detection window exceeds the fixed time. The printer detects the toner level when the printer is turned on, or while the stirring plate is rotating.



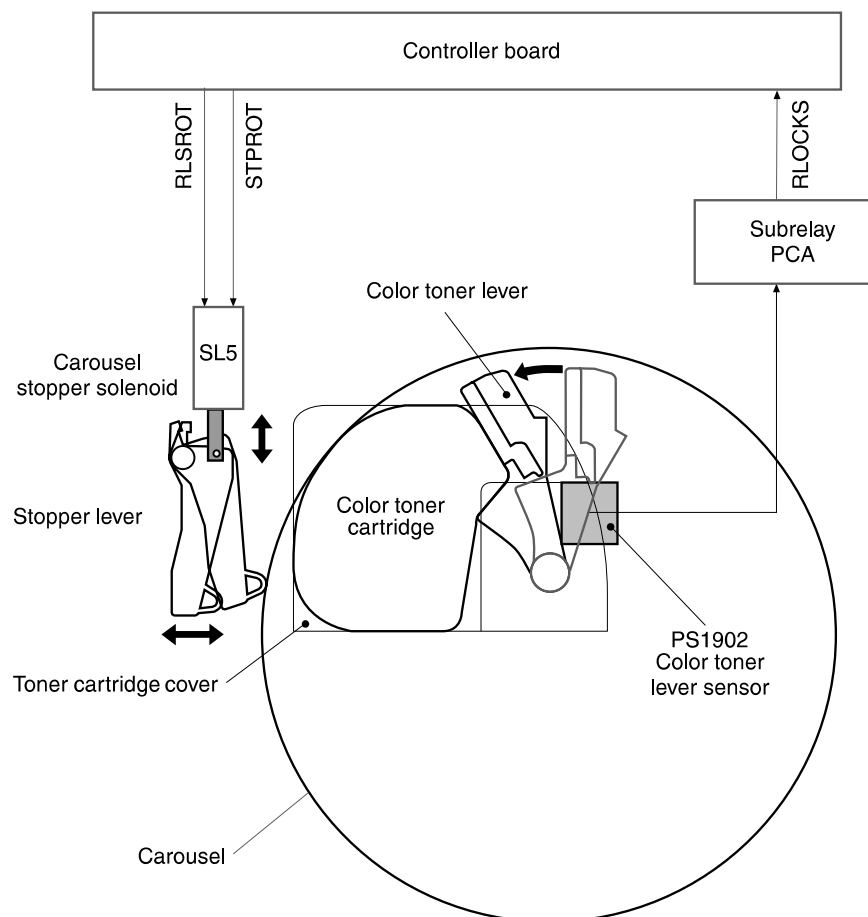
**Figure 41. Color toner level detections**

## Color cartridge sensor

The color cartridge sensor (PS1901C) detects the color toner cartridge. PS1901C consists of a light emitter and a light receiver. The light from the light emitter is reflected by the cartridge and reaches to the light receiver only when the cartridge is installed. If the light does not reach the light receiver, the controller board signals color toner cartridge failure to the formatter and stops the printer. Also, the printer checks for the cartridge pressure when the power switch is turned on, or right after any cover is opened or closed.

## Color toner lever detection

The printer has a color toner lever sensor (PS1902) to prevent toner cartridge setup failure. This sensor consists of a light emitter and a light receiver. If the color toner lever is set incorrectly, the light from the light emitter is reflected by the color toner lever and detected by the light receiver. The controller board monitors the sensor when the carousel door is closed. If the color toner lever is not locked in place, LOCK TONER LEVER is displayed on the printer control panel and the carousel will not rotate.



**Figure 42.** Color toner lever detection

## **Black toner level detection and cartridge detection**

The toner antenna in the black toner cartridge detects the black toner level. The controller board monitors the toner level sensor signal output from the toner antenna via high-voltage PCA 1. The controller board checks the signal at the moment that the black developing AC bias is applied to the black developing cylinder. If the toner level is less than specified, the controller board signals the formatter that the black toner cartridge has no toner. The black toner cartridge is detected by the black toner cartridge switch (SW644) in the printer.

## **Environment change control**

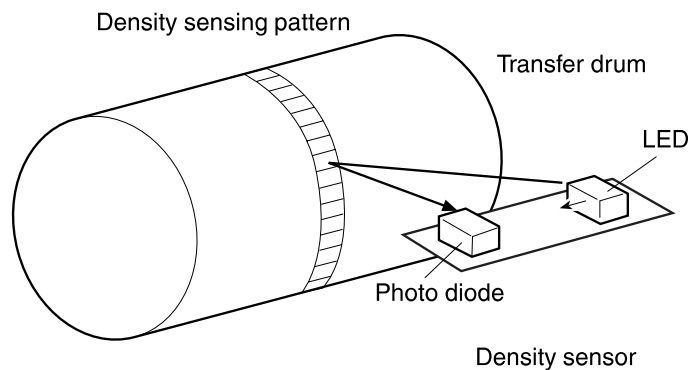
The controller board judges the temperature/humidity environment based on temperature/humidity sensor signals from the temperature/humidity sensors on the temperature/humidity sensor PCA and executes the following controls to obtain the appropriate image:

- Controls the value of the secondary transfer bias, the transfer drum cleaning bias, and the transfer charger bias.
- Performs a color calibration if the environmental change is great enough.

The controller board checks for an environment change before starting image density control, after the power is turned on, or every 30 minutes after the image density control is completed.

## Color calibration density sensor

The density sensor inside the right upper door senses the density detection pattern for each color formed on the transfer drum during a calibration cycle. The sensor emits light from the LED, and the density detection pattern on the transfer drum reflects the light. The sensor then receives the light with the photo diode and that information is converted to digital values and stored on the controller board. The controller board uses this information to control appropriate developing bias and primary charging bias values to stabilize density of each color.



**Figure 43.** Density sensor

Calibration occurs at the following intervals:

- After the power is turned on
- After 50 pages in one-page mode are printed (after initial power on)
- After 95 pages in one-page mode are printed
- After the printer is revived from Power Save (if Power Save has been on for more that 30 minutes)
- When a toner cartridge is installed
- When an imaging drum cartridge is installed
- When environment is changed by the environment change control

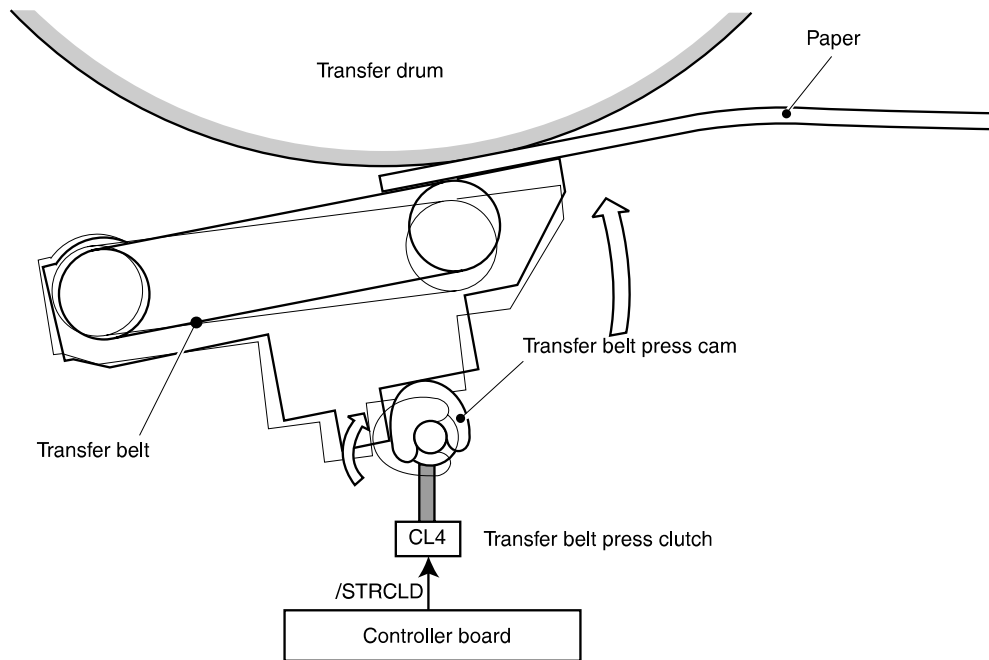
---

### Note

The density control will only be executed if all of the printer doors are closed and all of the printer components are detected.

## Transfer belt control

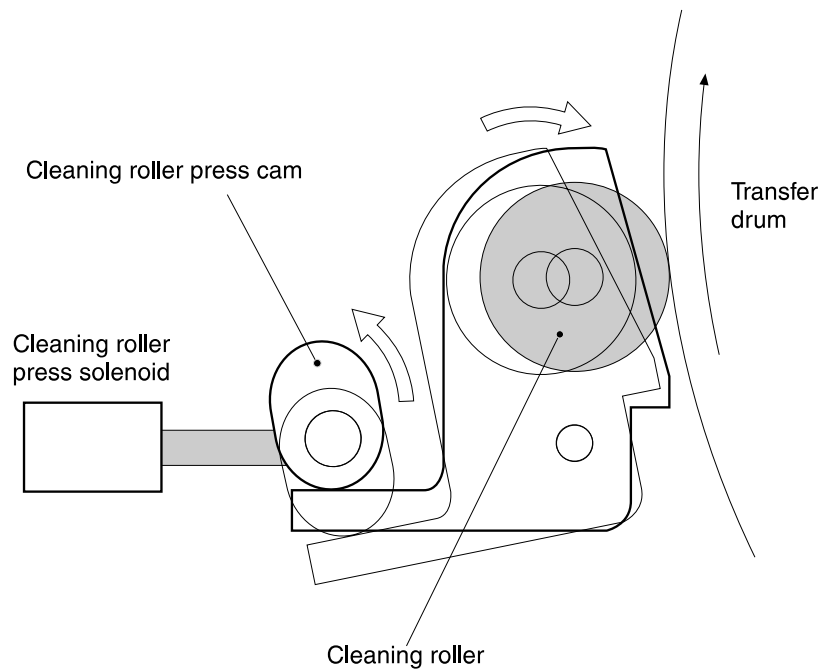
During secondary transfer, the controller board activates the transfer belt press clutch (CL4). The transfer belt is normally away from the transfer drum, except while pushed against the transfer drum during secondary transfer. When the secondary transfer is complete, the transfer belt is removed from the transfer drum when the controller board sets the CL4 to off.



**Figure 44.** Transfer belt control

## Cleaning roller control

The controller board activates the cleaning roller press solenoid (SL1). SL1 presses the cleaning roller to the transfer drum just after the secondary transfer begins. When the SL1 signals on, the cleaning roller press cam presses the cleaning roller, and the cleaning roller presses against the transfer drum. When the transfer drum cleaning and secondary transfer are complete, the controller board sets the SL1 off to detach the cleaning roller from the transfer drum.



**Figure 45.** Cleaning roller control

## Carousel control

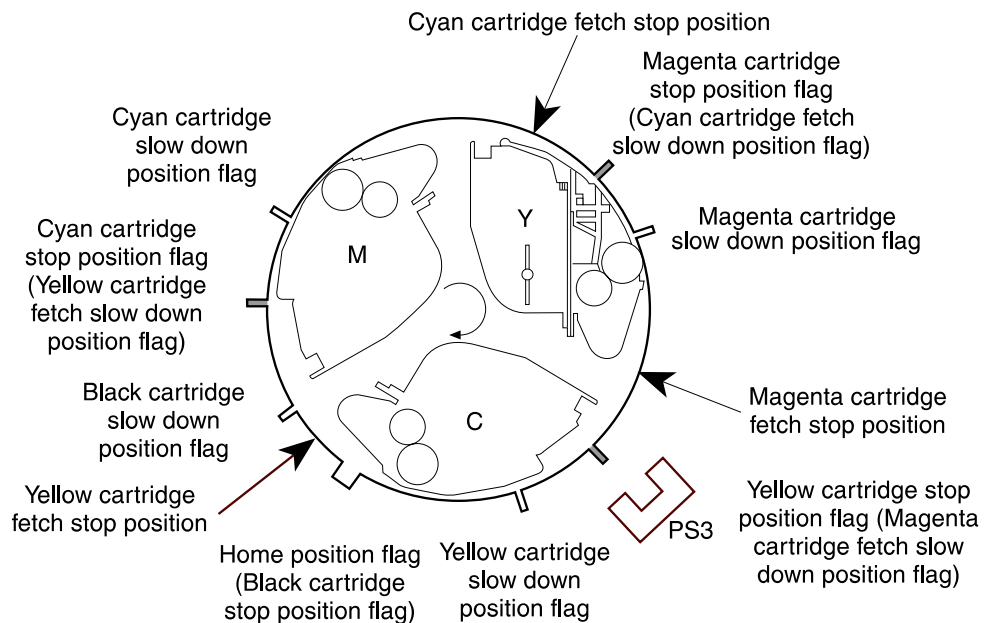
The controller board controls the rotation speed and the stop position of the carousel by monitoring the timing of the eight flags that pass through the carousel position sensor (PS3). The rotation position flags are located on the back side of the carousel. The eight rotation position flags consist of the home position flag (also the black toner



cartridge stop position flag); the yellow, magenta, and cyan cartridge stop position flags (three flags); and the fetch (removal or replacement) flags (four flags).

When the controller board receives the print signal from the formatter, the carousel motor (M1) is turned on at normal speed. When the controller board detects that the carousel rotation has reached the slow down position, the controller board reduces the carousel speed until the controller board senses that the carousel rotation has reached the stop position.

Figure 46 shows an example of the carousel in the yellow cartridge stop position where the printer is ready for yellow development. The yellow toner cartridge is facing the imaging drum.



**Figure 46. Carousel control**

### Carousel stop solenoid

The carousel lock control fixes the carousel by pushing the stopper lever against the carousel when the cartridge is moved to the fetch position. When a user presses the carousel rotation button while replacing the color toner cartridge, the carousel begins to rotate, then stops in the color toner cartridge fetch position. The carousel is fixed when the carousel stopper solenoid (SL5) pushes the stopper lever.

# Electrical systems

## Power distribution

The low-voltage power distribution circuit transforms the AC input voltage to supply the DC power sources, +24VB and +5V, on which the printer operates. The +24V source feeds the various motors, solenoids, and exhaust fans within the printer, while the +5V source feeds the controller board and image processor.

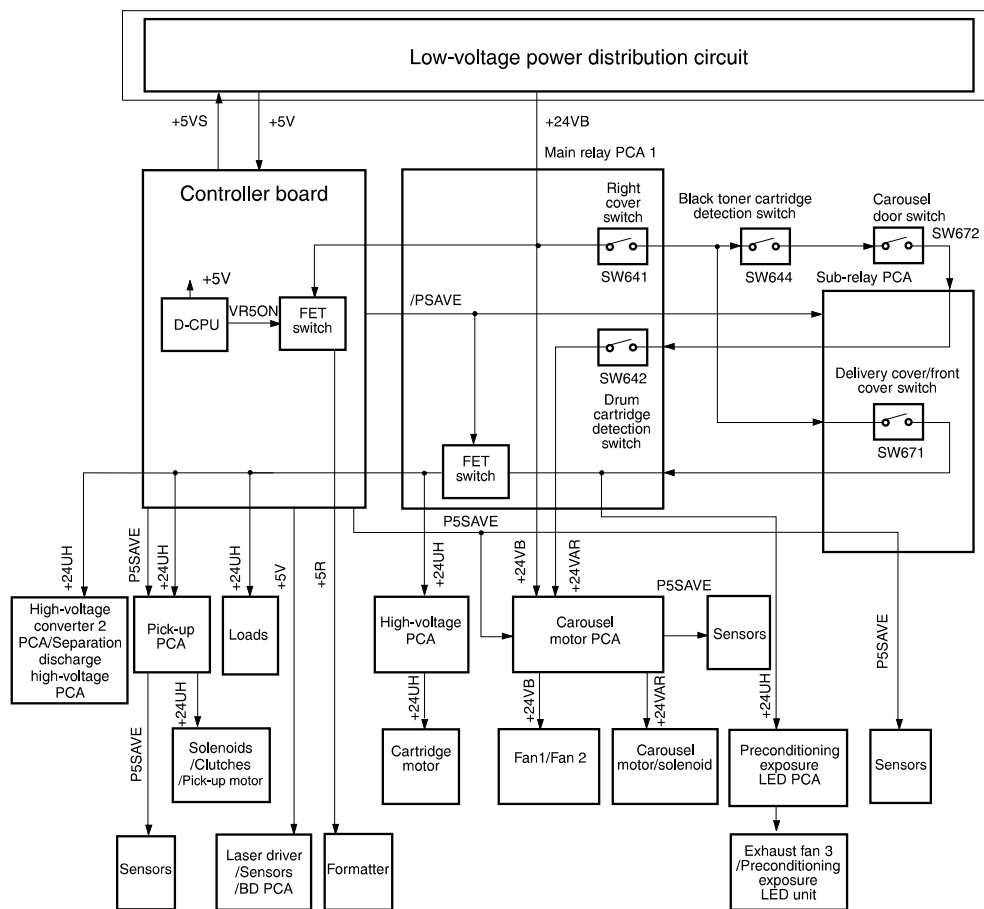
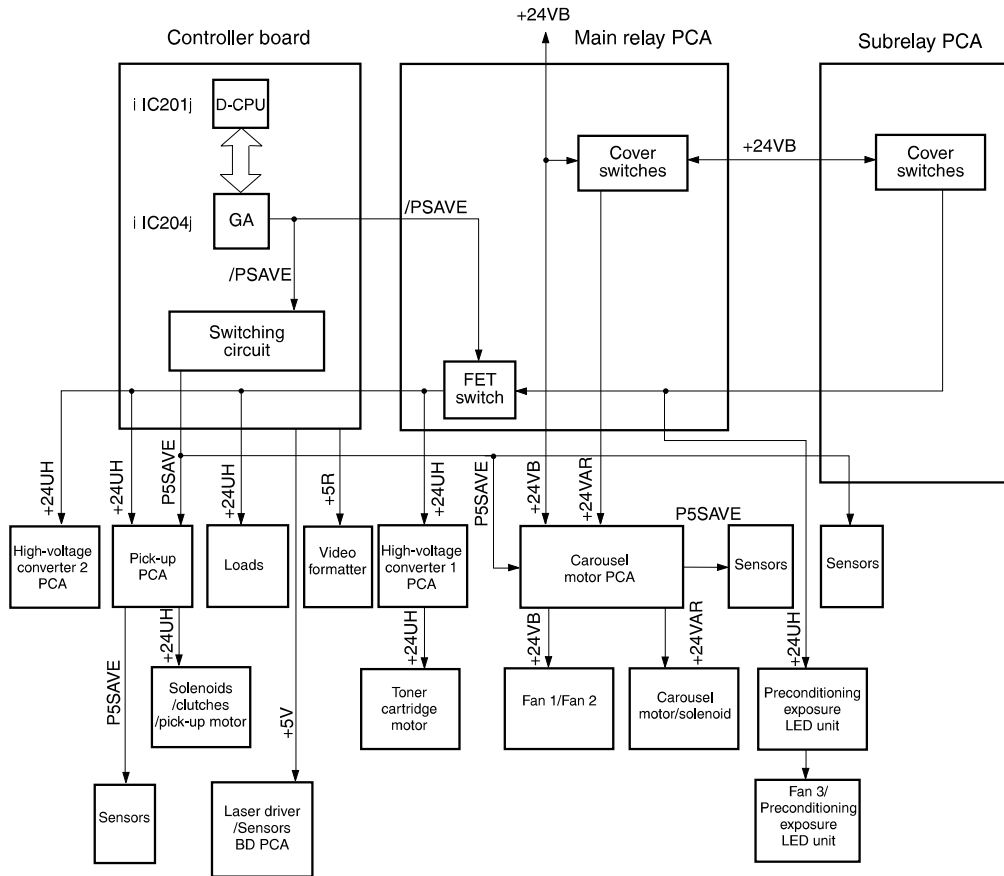


Figure 47. Power distribution circuit diagram

When the printer receives the Power Save command from the formatter board, the controller board turns off the FET switch in the main relay PCA and stops the supply of +24 UH. Additionally, the sensors, carousel motor, and toner cartridge motor are turned off. After the fuser cools down, all fans are also turned off. When the printer receives the “wake up” command from the formatter board, the printer leaves Power Save mode and resumes normal operation.



**Figure 48.** Power Save circuit diagram

## Fuser control

The fuser controller directly interfaces with both the power supply and controller board. As the surface temperature of the upper and lower fusing rollers rises, the resistance of the thermistors drops and the voltage of the fusing temperature detection signals also drops.

Table 27 shows the temperature the formatter sets the temperature to based on the type of media being used.

**Table 27. Fusing temperatures**

Target temperature	Color mode	Number of sheets	Fusing mode			
			Plain paper	OHT	Heavy or glossy	Envelope
	Target temperature	Full color	1st sheet	175° C 347° F	175° C 347° F	175° C 347° F
2nd and after			165° C 329° F	170° C 338° F	165° C 329° F	180° C 356° F
Black-and-white		1st sheet	180° C 356° F	175° C 347° F	175° C 347° F	180° C 356° F
		2nd and after	165° C 329° F	170° C 338° F	165° C 329° F	170° C 338° F

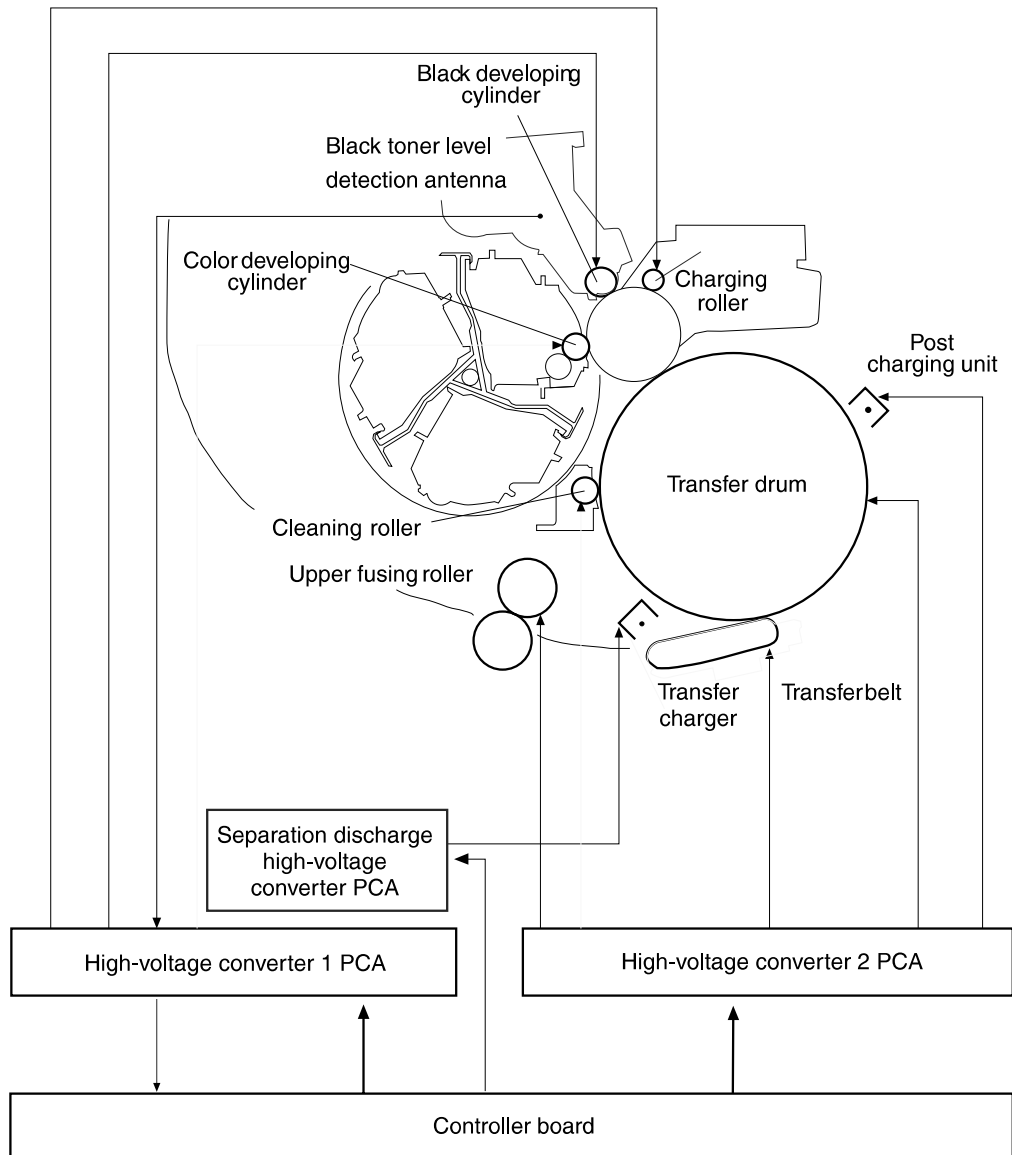
Problems in the fuser can be detected in the following three circuits:

- Controller board. If the fuser is heated abnormally or does not reach the specified temperature for some reason, the controller board interrupts power to the fuser heaters. From there, the formatter assesses the fusing heater failure and signals the printer control panel.
- Fusing heater safety circuit (in the power supply circuit). If the fusing heater safety circuit detects an upper or lower fusing heater failure, the safety circuit interrupts power to the upper and lower fusing heaters.
- Fuser abnormality detection circuit (in the power supply circuit). If there are broken wires to the fusing heater system, the fuser abnormality detection circuit detects no AC current flow, causing the controller board to assess the broken wires, stop driving the fusing heaters, and signal the printer control panel.

## High-voltage power supply circuit

The printer contains three high-voltage PCAs (shown in figure 49) that are directly controlled by the controller board:

- High-voltage converter 1 PCA which controls:
  - cartridge motor (M3)
  - imaging drum bias
  - black developing bias
  - color developing bias
- High-voltage converter 2 PCA which controls:
  - transfer drum
  - cleaning roller
  - transfer belt
  - post charging unit
  - upper fusing roller
- Separation discharge high-voltage converter PCA which controls:
  - transfer charger



**Figure 49.** High-voltage power supply circuit

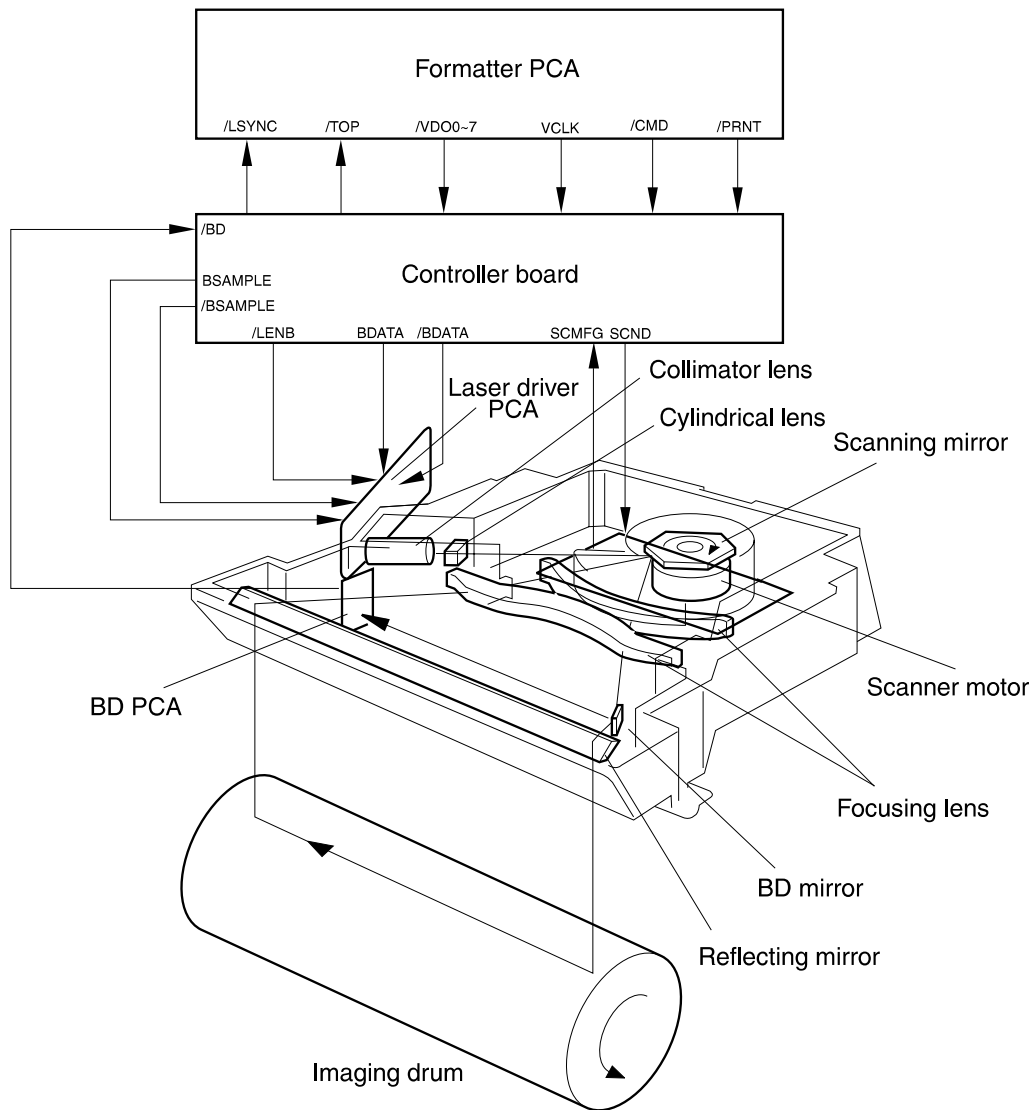
## Mechanical systems

### Laser/scanner

The laser/scanner unit scans the laser beam across the imaging drum. Video signals sent from the formatter are pulse-width modulated and converted to video data signals. The video data signals are then converted to two low-voltage differential signals (which suppress radio frequency emissions), and are sent to the laser driver PCA. There the voltage differential signals are converted to a single laser drive signal (the internal signal of the laser/scanner unit) in the laser driver PCA, which turns the laser diode on and off and generates the modulated laser beam.

The modulated laser beam is aligned by the collimator lens and the cylindrical lens, becoming a parallel beam. The laser beam then strikes the scanning mirror that rotates at a constant speed. The beam reflected from the scanning mirror travels through the focusing lens and the reflecting mirror located in front of the scanning mirror, and is brought to a focus point on the imaging drum.

The scanning mirror rotates at a constant speed, so the laser beam is scanned across the drum at a constant speed. The drum is also rotating at a slower constant speed, which allows the laser beam to form an image on the drum surface.



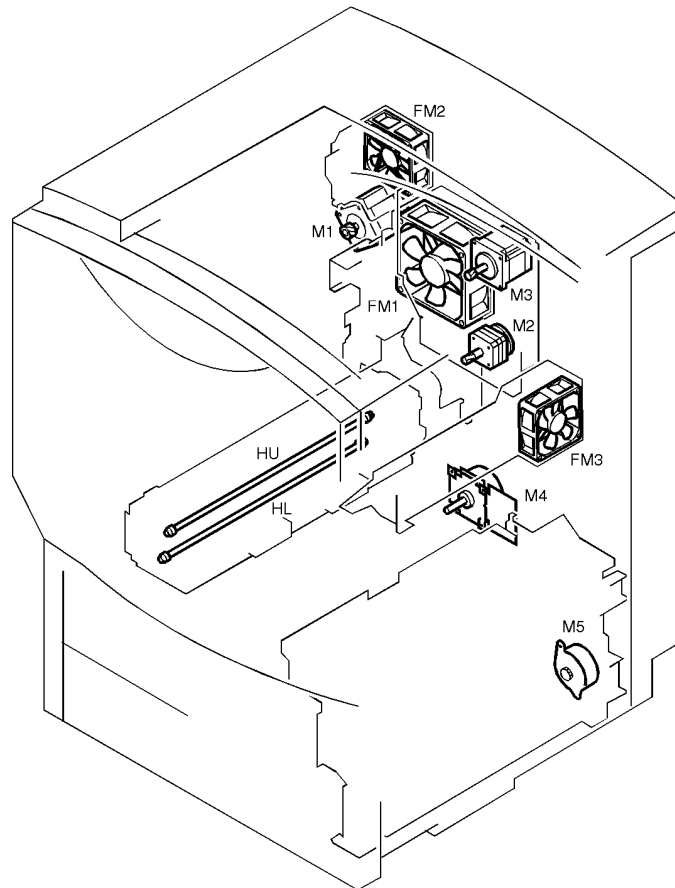
**Figure 50. Laser/scanner**

If the laser/scanner motor does not reach operating speed within seven seconds of rotation, then the laser/scanner motor lock detection circuit generates a scanner motor failure, and the laser/scanner motor stops.



## Motors and heaters

The following section describes the motors and heaters in the printer.



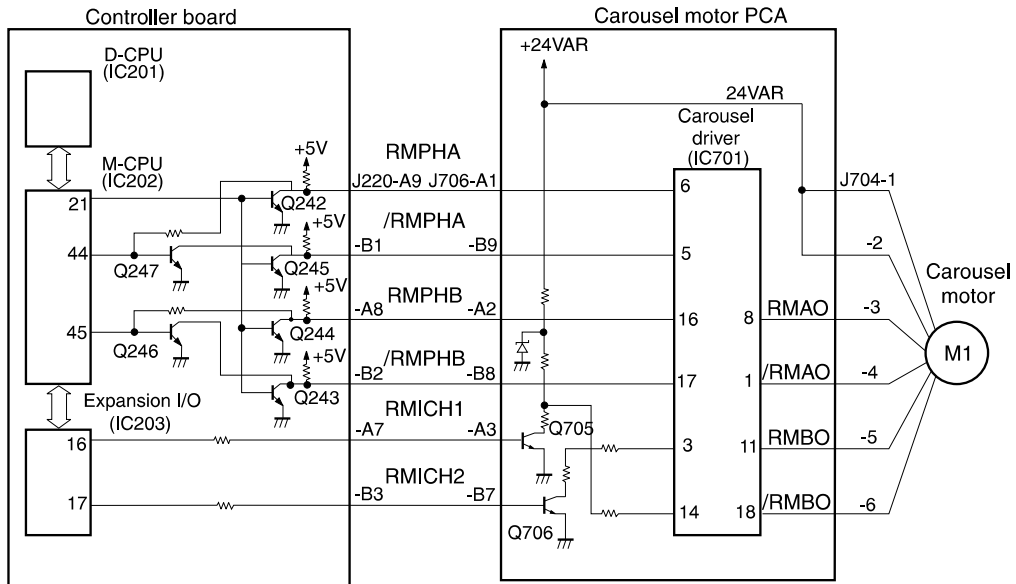
**Figure 51.** Printer motors and heaters

**Table 28. Printer motor and heater names and descriptions**

Name	Description	Name	Description
M1	Carousel motor	FM1	Fan 1 motor
M2	Drum motor	FM2	Fan 2 motor
M3	Cartridge motor	FM3	Fan 3 motor
M4	Main motor	HU	Upper fuser heater
M5	Pick-up motor	HL	Lower fuser heater

## Carousel motor (M1)

The carousel motor (M1) is a two-phase stepping motor, and rotates the carousel. The motor operates at low and normal speeds depending on the printer function (such as sensing toner cartridges or printing).

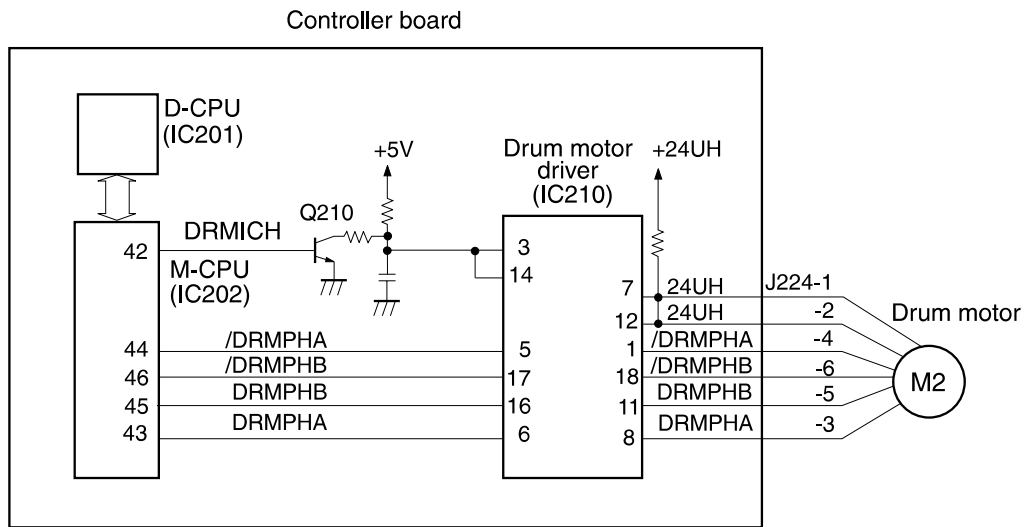


**Figure 52.** Carousel motor (M1)

## Drum motor (M2)

The drum motor (M2) is a two-phase stepping motor, and drives the transfer drum and the imaging drum.

For overhead transparencies and glossy or heavy media, the motor rotates at low speed (OHT mode: 1/4 speed rotation, glossy and heavy media: 1/3 speed rotation). The speed of the media through the fuser is identical to the speed at which the media passed through the image transfer process.

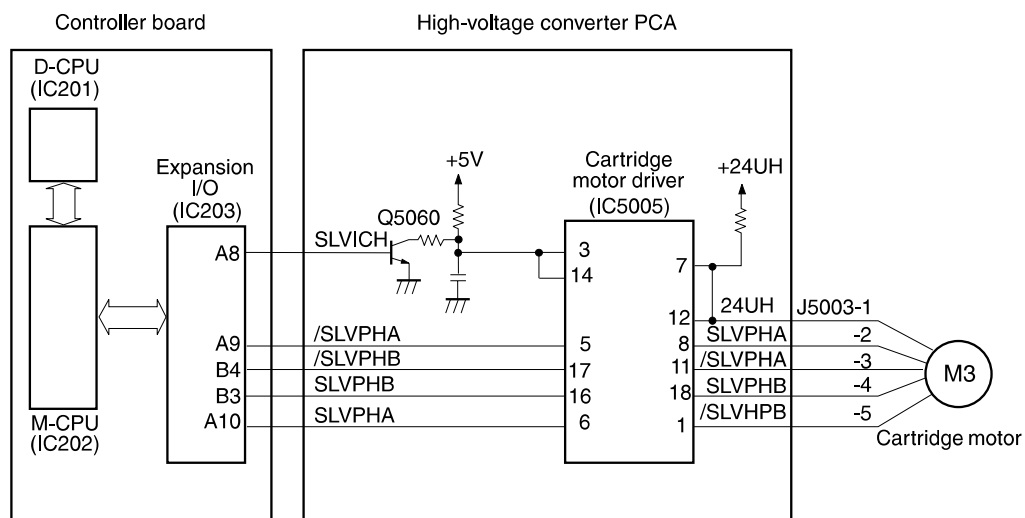


**Figure 53.** Drum motor (M2)

## Cartridge motor (M3)

The cartridge motor (M3) is a two-phase stepping motor, and drives the black and color toner cartridge developing cylinders.

The motor rotates in the normal direction for color toner development, then the motor reverses for black toner development. The developer gear drive assembly and its associated clutches engage the proper developer drive gear based on the direction of the cartridge motor rotation.



**Figure 54.** Cartridge motor (M3)

## Main motor (M4)

The main motor (M4) is a three-phase, eight-pole, brushless motor. This motor drives the rollers related to pick-up, feeding, fusing, and delivery. This motor also drives the transfer belt press drive cam and cleaning roller press drive cam.

The controller board switches the motor speed between normal speed, 1/4 speed for OHT mode, and 1/3 speed for glossy or heavy media by combining the M4 speed change signals.

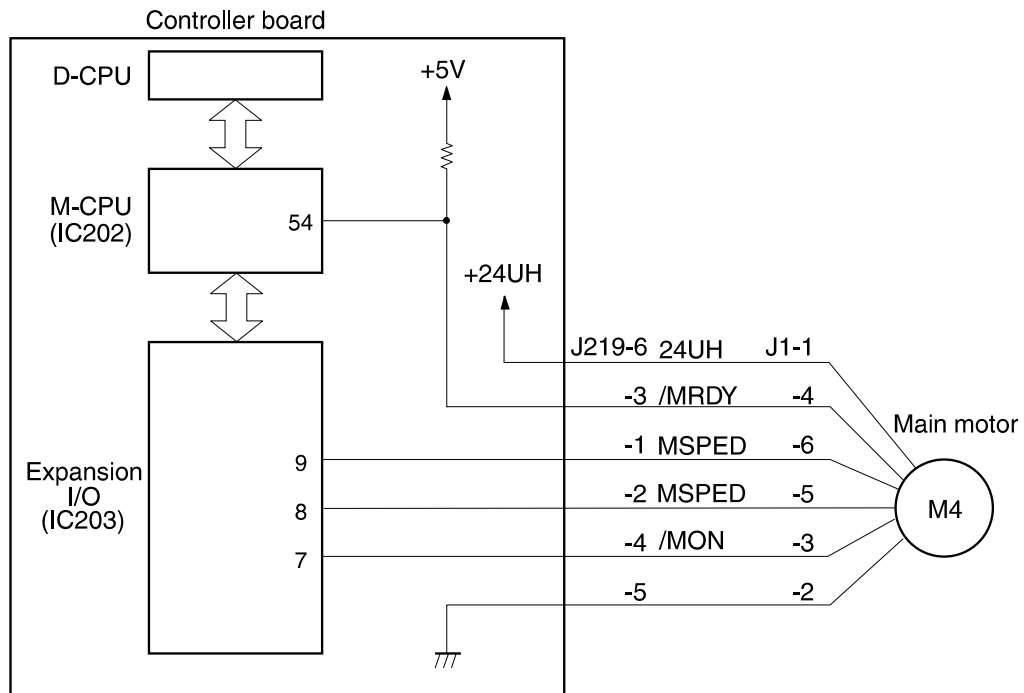


Figure 55. Main motor (M4)

## Pick-up motor (M5)

The pick-up motor (M5) is a two-phase stepping motor. M5 picks up the paper, drives tray 2 and 3 tray lifts, and activates the pick-up rollers for trays 2 and 3. During tray 2 paper pick-up, M5 is rotated at normal speed. During tray 3 pick-up, normal speed reverse rotation is used.

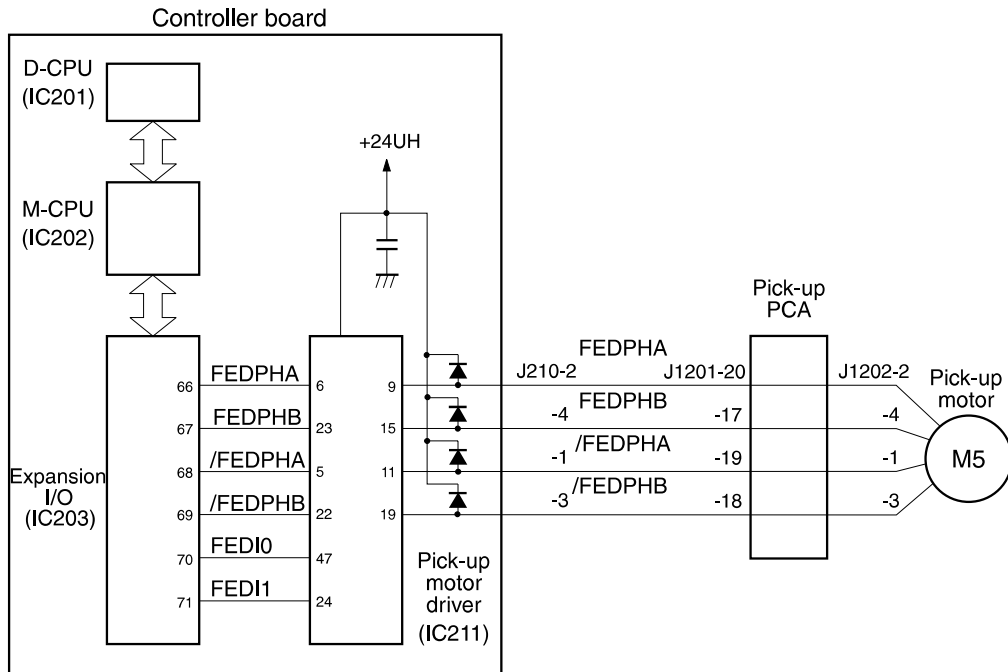


Figure 56. Pick-up motor (M5)

### Fan motors (FM1, FM2, and FM3)

The printer contains three exhaust fans, all of which use DC brushless motors. Table 29 describes when each of the fans operates and at what speed they operate.

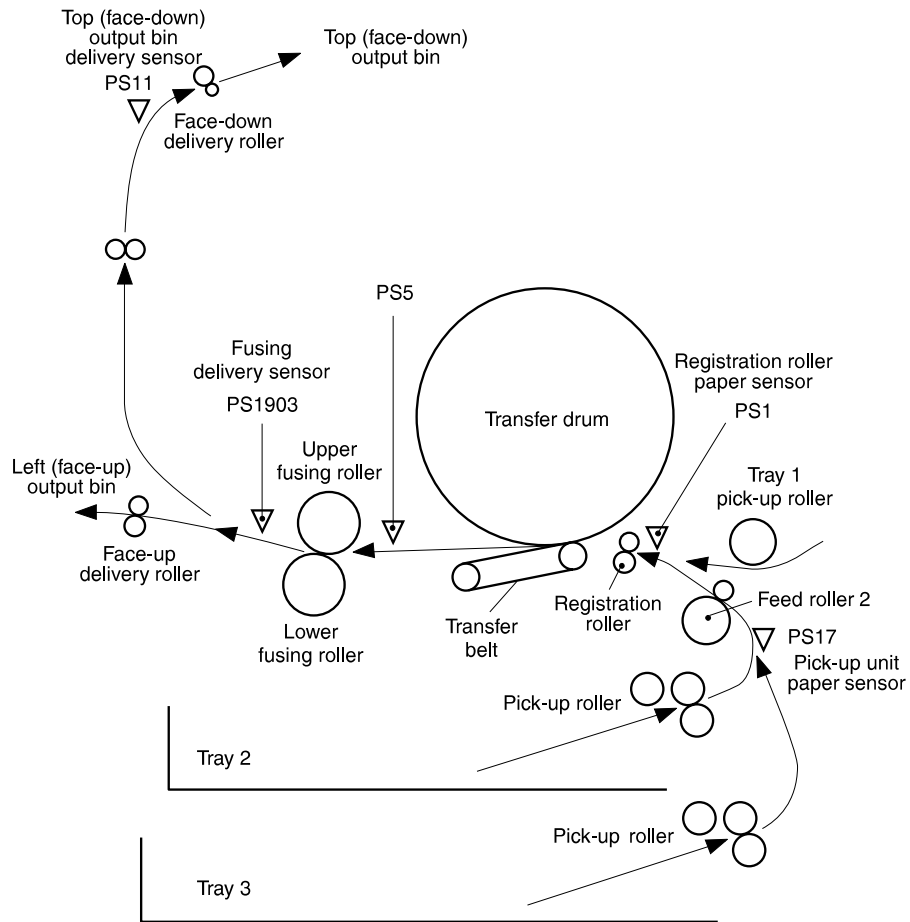
**Table 29. Fan operation**

	Turn printer on	Standby	Printing	Power Save or power off <30 minutes	Power Save or power off >30 minutes
<b>FM1</b> <sup>1</sup>	Full speed	On	On	On	Off
<b>FM2</b>	Full speed	Full speed	Full speed	Full speed	Off
<b>FM3</b>	Off	Off	Full speed	Off	Off

<sup>1</sup> FM1 contains a thermistor, and the fan speed changes according to the temperature inside the printer.

## Paper path

Figure 57 shows the printer paper path.



**Figure 57.** Paper path



## Pick-up/feed

For cassette paper pick-up, the paper is sent into the printer by the pick-up roller, then fed by the feed roller. After the registration roller corrects the skew of the paper, the paper stops. The paper is then refeed so that its leading edge will match the top of the image on the transfer drum. After that, the paper is fed through the transfer, separation, and fusing/delivery units to the top (face-down) or the left (face-up) output bin. The printer switches the speed at which the paper is fed for different media types as indicated in table 30.

**Table 30. Feed speeds based on media type**

Modes	Plain paper	Glossy or heavy media	OHT
Feed speed	Normal speed	1/3 of normal speed	1/4 of normal speed

The controller board switches the feed speed when the registration roller paper sensor detects the paper. The printer has two overhead transparency sensors (PS1801 and PS1802, see figure 60 on page 172), and the controller board always monitors these sensors.

## Automatic overhead transparency detection

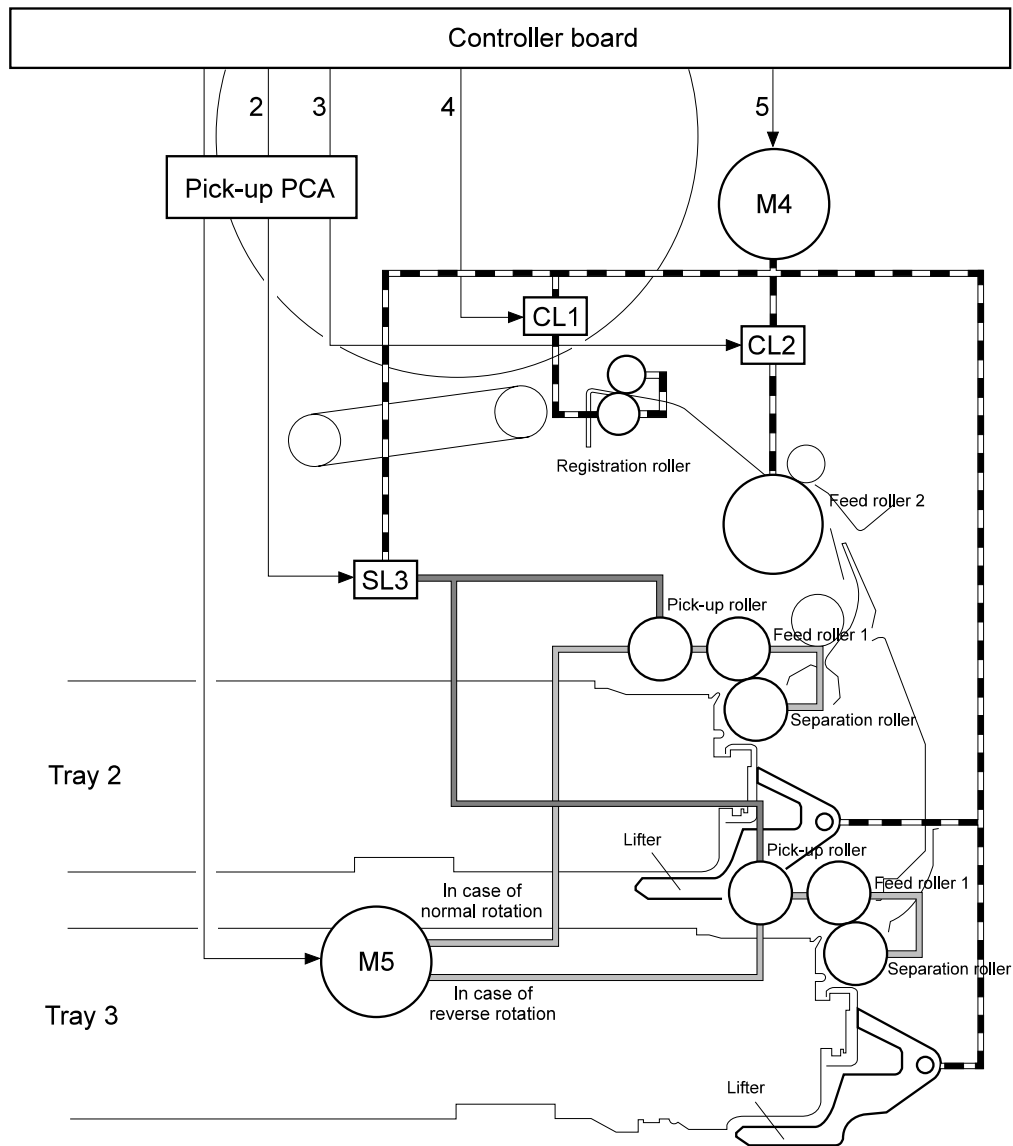
The printer enters overhead transparency (OHT) mode when the user selects to print on transparencies through the printer driver or by selecting OHT as the media type in the printer control panel. The OHT sensors (PS1801 and PS1802, see figure 60 on page 172) are installed in front of the registration roller to detect transparencies even if the media type has not been set at the printer control panel by the user. The controller board monitors these sensors to execute the automatic overhead transparency detection.

PS1801 and PS1802 consist of light emission and light reception units. When a transparency is used, the light emitted from the light emitter unit goes through the transparency and is received by the light receptor. As a result, the controller board determines that the fed media is a transparency and enters the OHT mode.

## Paper pick-up

Paper pick-up begins when the print signal is sent. The pick-up roller is lowered to the paper level, and the main motor (M4) rotates the roller. This process feeds the paper into the printer from the input trays.

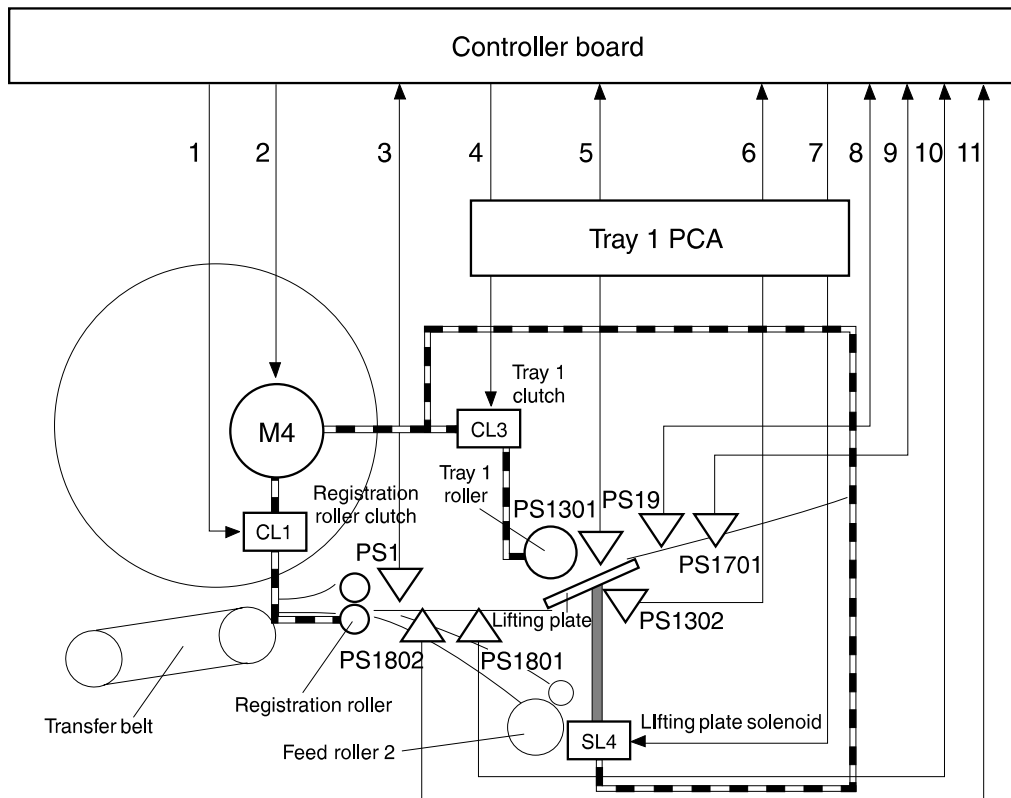
- **Tray pick-up** — When the pick-up motor is in normal rotation, the tray 2 pick-up roller, feed roller 1, and separation roller are driven. The paper is then picked up from the tray 2 pick-up roller. In the case of reverse rotation, the tray 3 pick-up roller, feed roller 1, and separation roller are driven. The paper is then picked up from the tray 3 pick-up roller.
  - **Multi-feed prevention mechanism** — During paper pick-up from tray 2 or 3, the separation roller prevents multi-feeding.
  - **Tray 2 last page detection** — The last page sensor (PS29) consists of a light emitter and light receiver. When paper is present in tray 2, the light from the light emitter is reflected by the paper and received by the light receiver. However, when the last page is picked up, the light from the light emitter is transmitted inside the printer and does not reach the light receiver. The controller board signals the formatter that there is no paper in tray 2 and stops formation of the next image. The tray 2 last page detection prevents the imaging drum and the transfer drum from getting dirty by detecting that no paper is available before the next image is written.



**Figure 58. Tray 2 and 3 pick-up**

<b>1</b> Pick-up motor drive signal	<b>M4</b> Main motor
<b>2</b> Feed roller clutch drive signal	<b>M5</b> Pick-up motor
<b>3</b> Tray pick-up solenoid drive signal	<b>SL3</b> Tray pick-up solenoid
<b>4</b> Registration roller clutch drive signal	<b>CL1</b> Registration roller clutch
<b>5</b> Main motor drive signal	<b>CL2</b> Feed roller clutch

- **Tray 1 pick-up** — One sheet of paper is pressed to the multi-purpose pick-up roller by the paper lifting plate and is picked up by the rotation of the pick-up roller. Any extra sheets are removed by the separation pad then sent inside the printer. Operation after transmission is the same as for tray pick-up except that the paper lifting plate solenoid is re-set on to lower the paper lifting plate right after registration roller rotation.
- **Tray 1 paper width sensor** — The tray 1 paper width sensor (PS1701) detects the paper width when the user adjusts the media width guides, which moves the slide resistance connected with the size-control plate. When paper is loaded in tray 1, the controller board detects the paper width. If the paper width is not the width specified by the formatter, the controller board notifies a paper size failure to the formatter and stops the printer.
- **Tray 1 last page detection** — The tray 1 last page sensor (PS19) monitors the rotation of the last page detection roller in tray 1 and detects the last page. If the tray has two or more pages, the last page detection roller does not rotate at pick-up. When the last page is picked up, the last page detection roller rotates by the page and PS19 and sends an off to signal the controller board. The controller board then signals the formatter that no pages are in tray 1 and stops the next image formation. The PS19 detects no page before the next image is written and prevents the imaging drum and the transfer drum from getting dirty.

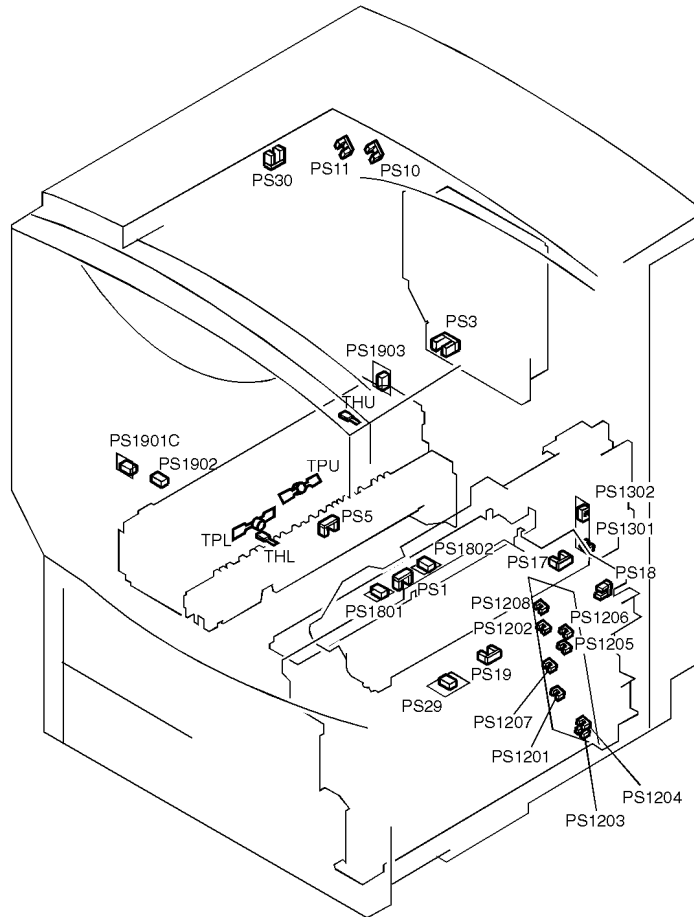


**Figure 59. Tray 1 pick-up**

<b>1</b>	Registration roller clutch drive signal	<b>SL4</b>	Lifting plate solenoid
<b>2</b>	Main motor drive signal	<b>CL1</b>	Registration roller clutch
<b>3</b>	Registration roller paper detection signal	<b>CL3</b>	Tray 1 pick-up clutch
<b>4</b>	Tray 1 pick-up clutch drive signal	<b>PS1</b>	Registration roller paper sensor
<b>5</b>	Tray 1 paper detection signal	<b>PS19</b>	Tray 1 last page sensor
<b>6</b>	Lifting plate position detection signal	<b>PS1301</b>	Tray 1 page sensor
<b>7</b>	Lifting plate solenoid drive signal	<b>PS1302</b>	Lifting plate position sensor
<b>8</b>	Tray 1 last paper detection signal	<b>PS1701</b>	Tray 1 paper width sensor
<b>9</b>	Tray 1 paper width detection signal	<b>PS1801</b>	OHT sensor 1
<b>10</b>	OHT detection signal	<b>PS1802</b>	OHT sensor 2
<b>11</b>	OHT detection signal		

## Sensors, switches, clutches, and solenoids

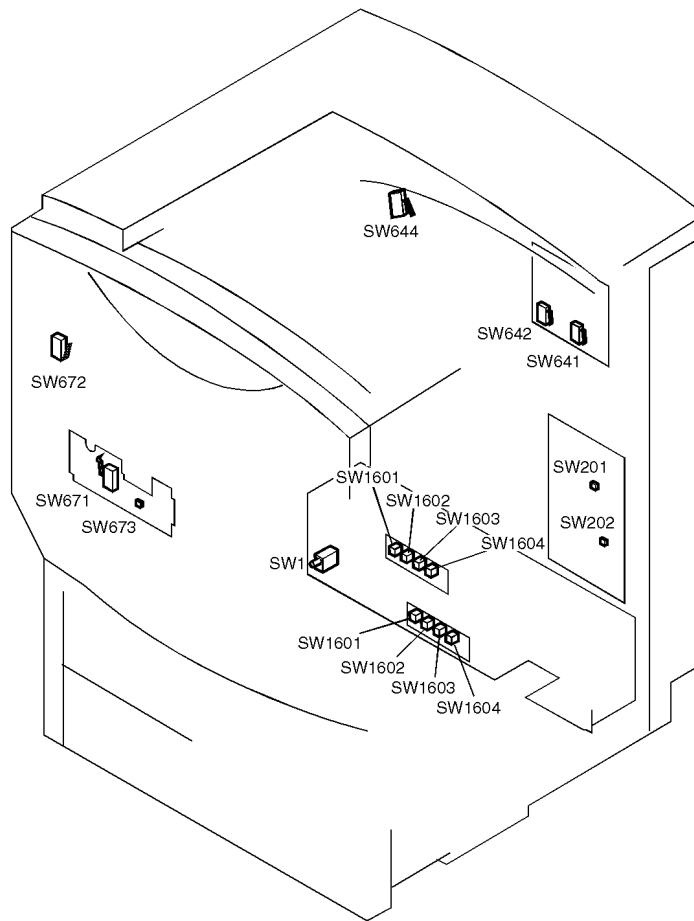
The following figures and tables illustrate and describe the sensors, switches, clutches, and solenoids in the printer paper path.



**Figure 60.** Printer sensors

**Table 31. Printer sensor names and descriptions**

<b>Name</b>	<b>Description</b>
PS1	Registration roller paper sensor
PS3	Carousel position sensor
PS5	Separation sensor
PS10	Top (face-down) output bin paper full sensor
PS11	Top (face-down) output bin delivery sensor
PS17	Pick-up unit paper sensor
PS18	Pick-up unit cover sensor
PS19	Tray 1 last page sensor
PS29	Tray 2 last page sensor
PS30	Left cover sensor
PS1201	Tray 3 sensor
PS1202	Tray 2 sensor
PS1203	Tray 3 paper level sensor 2
PS1204	Tray 3 paper level sensor 1
PS1205	Tray 2 paper level sensor 2
PS1206	Tray 2 paper level sensor 1
PS1207	Tray 3 paper out sensor
PS1208	Tray 2 paper out sensor
PS1301	Tray 1 paper sensor
PS1302	Lifting plate position sensor
PS1801	OHT sensor 1
PS1802	OHT sensor 2
PS1901C	Color toner cartridge sensor
PS1902	Color toner lever sensor
PS1903	Fusing delivery sensor
THU	Upper thermistor
THL	Lower thermistor
TPU	Upper thermo switch
TPL	Lower thermo switch



**Figure 61. Printer switches**



**Table 32. Printer switch names and descriptions**

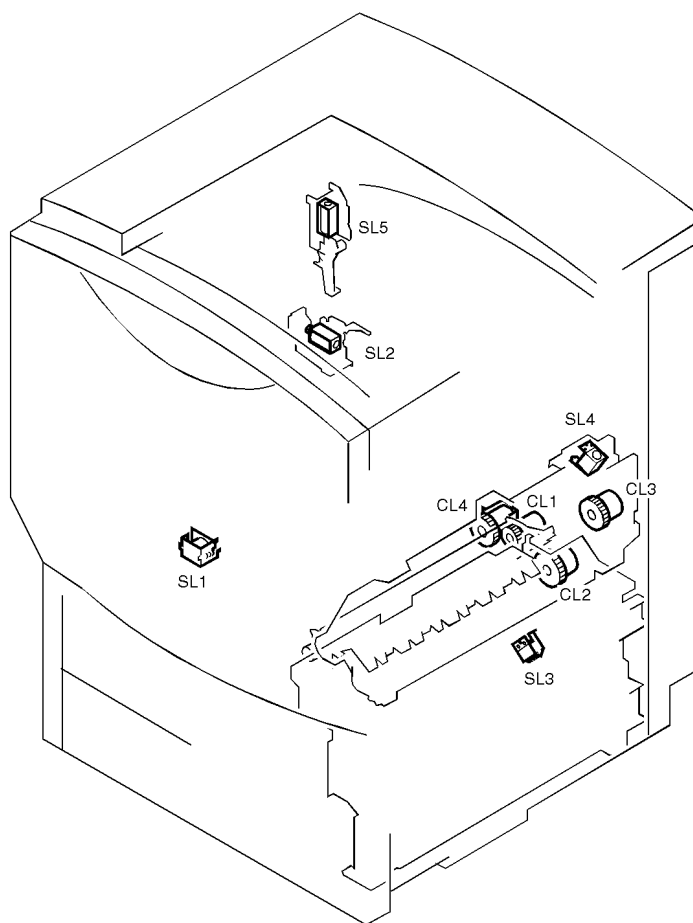
<b>Name</b>	<b>Description</b>
SW1	Power switch
SW201	Test print switch
SW202	Reset switch
SW641	Right cover switch
SW642	Imaging drum switch
SW644	Black toner cartridge switch
SW671	Delivery cover / front cover switch
SW672	Toner cartridge cover switch
SW673	Carousel button switch
SW1601	Tray 3 paper size detection switch
SW1602	Tray 3 paper size detection switch
SW1603	Tray 3 paper size detection switch
SW1604	Tray 3 paper size detection switch
SW1601	Tray 2 paper size detection switch
SW1602	Tray 2 paper size detection switch
SW1603	Tray 2 paper size detection switch
SW1604	Tray 2 paper size detection switch

## Switch functionality

The following table describes the functionality of the paper size switches in the printer.

**Table 33. Tray 2 and Tray 3 paper size detection**

Paper size	Paper size detection switches			
	SW1601	SW1602	SW1603	SW1604
A3	Off	On	Off	Off
A4 (horizontal)	Off	Off	On	Off
A4 (landscape)	On	Off	Off	On
A5	Off	Off	On	On
B4	On	Off	Off	Off
B5	Off	On	Off	On
Ledger	Off	Off	Off	Off
Legal	On	On	Off	Off
Letter (horizontal)	Off	Off	Off	On



**Figure 62. Printer clutches and solenoids**

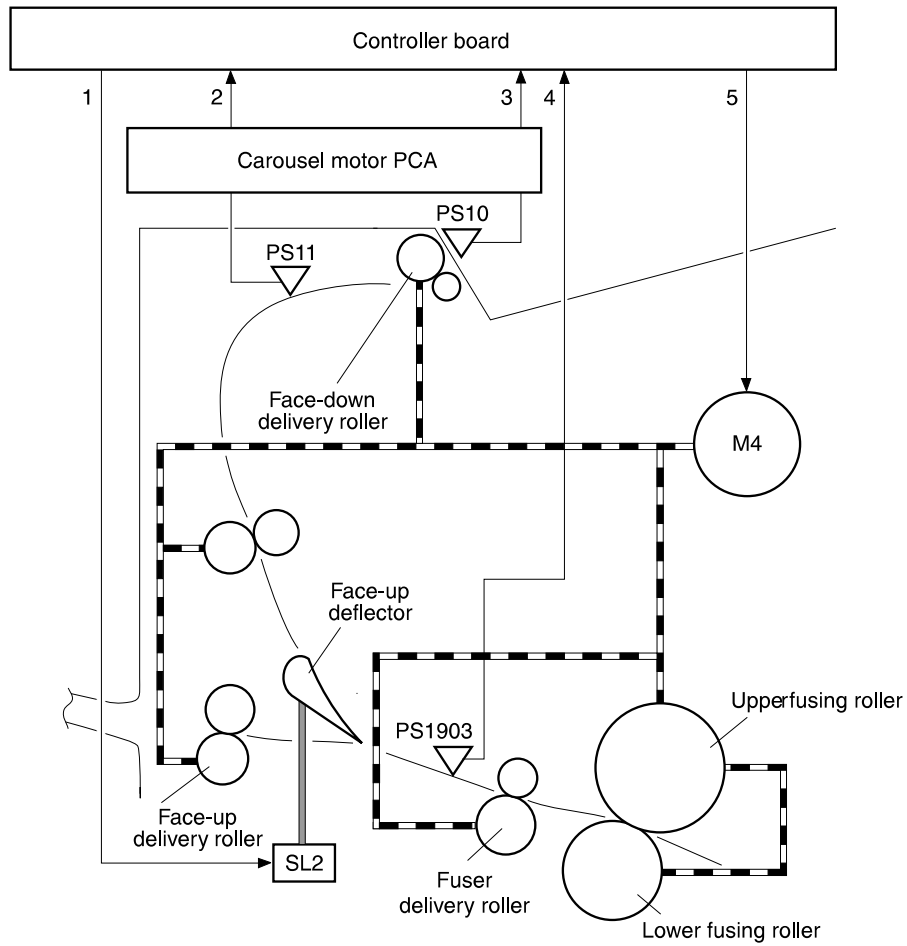
**Table 34. Printer clutch and solenoid names and descriptions**

Name	Description	Name	Description
<b>CL1</b>	Registration roller clutch	<b>SL3</b>	Tray 2 and tray 3 pick-up solenoid
<b>CL2</b>	Feed roller clutch	<b>SL4</b>	Lifting plate solenoid
<b>CL3</b>	Tray 1 pick-up roller clutch	<b>SL5</b>	Carousel stopper solenoid
<b>CL4</b>	Transfer belt press clutch		
<b>SL1</b>	Cleaning roller press solenoid		
<b>SL2</b>	Left (face-up) output bin solenoid		

## **Fusing and delivery unit**

The upper and lower rollers in the fuser and the face-up and face-down delivery rollers are driven by the main motor (M4). Paper separated from the transfer drum is fed into the fuser and delivered from the unit via the fusing roller and the fusing delivery roller. The fusing delivery sensor detects paper delivered from the fuser.

The printer has a left (face-up) output bin and a top (face-down) output bin, and diverts the media to the output bins using the face-up flapper. When the face-up output bin solenoid drive signal turns off, the face-up solenoid moves the face-up flapper to face the face-up output bin. From there, the paper is delivered to the face-up output bin. When the face-up solenoid drive signal turns on, the paper is delivered to the face-down output bin. Paper delivered to the face-down output bin is detected by the face-down output bin delivery sensor. When paper fills the face-down output bin, it is detected by the face-down output bin paper full sensor.



**Figure 63. Fusing and delivery unit**

<b>1</b> Left (face-up) output bin solenoid drive signal	<b>PS10</b> Top (face-down) output bin paper full sensor
<b>2</b> Top (face-down) output bin delivery detection signal	<b>PS11</b> Top (face-down) output bin delivery sensor
<b>3</b> Top (face-down) output bin paper full detection signal	<b>PS1903</b> Fusing delivery sensor
<b>4</b> Fusing delivery detection signal	<b>SL2</b> Left (face-up) output bin solenoid
<b>5</b> Main motor (M4) drive signal	<b>M4</b> Main motor

## Media jam detection

The controller board checks if paper is at the appropriate sensor at the proper time. If the controller board detects a media jam, the printer stops printing and signals a jam condition to the formatter board.

## EPH controller board

The external paper-handling (EPH) controller board controls the communication from the printer to the input and output devices. The EPH controller board PCA is integrated onto the printer formatter PCA.

## 2,000-sheet input unit

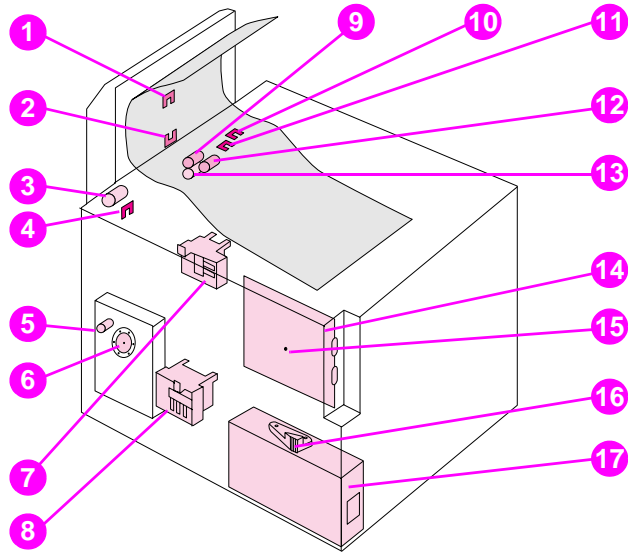
The 2,000-sheet input unit is a multi-speed high-capacity device that feeds paper to the printer. The 2,000-sheet input unit also automatically senses the paper size.

## Power supply

The 2,000-sheet input unit has an internal power supply that is activated when the printer power switch is turned on. The EPH controller board on the printer sends a power-on signal to the power supply on the 2,000-sheet input unit. When the signal is high, the power supply provides both +24V and +5V to the paper deck driver. The +24V drives the motors, clutches, and solenoids for the lifter, feed, and pick-up systems. The +5V drives the sensors and PCA electronics.

## Sensors, switches, clutches, and motors

Figure 64 and table 35 illustrate and describe the sensors, switches, clutches, and motors on the 2,000-sheet input unit.



**Figure 64.** 2,000-sheet input unit sensors, switches, clutches, and motors

**Table 35. 2,000-sheet input unit sensors, switches, clutches, and motors**

Ref.	Control device	Description
1	PS32	Paper exit sensor
2	PS31	Paper entry sensor
3	CL32	Main drive clutch
4	PS35	Vertical transfer unit (VTU) closed sensor
5	CL31	VTU clutch
6	MT31	Main motor
7	SW601 - SW602	Paper quantity switches
8	SW701 - SW704	Paper size switches
9	PS34	Paper tray raised sensor
10	PS33	Paper tray empty sensor
11		Feed roller
12		Pick-up roller
13		Separation roller
14		Controller board PCA
15		Diagnostic LEDs
16		Normal/diagnostic mode switch
17		Power supply

## Pick-up and feed system

When the 2,000-sheet input unit is loaded with paper and the paper tray is closed, the paper stack lifts into position under the pick-up, feed, and separation rollers. This operation is detected by the PS34 sensor in the 2,000-sheet input unit's pick-up assembly. The presence of paper in the paper tray is detected by the PS33 sensor. The paper level is detected by switches SW601 and SW602. The paper size is detected by switches SW701 through SW704.

When the EPH controller board on the printer sends an input command to the controller board PCA on the 2,000-sheet input unit, the paper deck driver runs the pick-up motor to rotate the pick-up,



feed, and separation rollers. As the pick-up roller turns, the paper feeds into the vertical transfer unit (VTU) and passes through the PS31 and PS32 sensors.

If the paper fails to reach the PS31 and PS32 sensors in the VTU within the allotted time, the controller board PCA on the 2,000-sheet input unit assumes that a paper jam has occurred. The 2,000-sheet input unit stops operating and reports a paper jam to the EPH controller board on the printer. A paper jam message appears on the printer control panel.

## Switch functionality

The following tables describe the functionality of the paper quantity and paper size switches in the 2,000-sheet input unit.

**Table 36. Paper quantity detection switches**

SW601	SW602	Remaining paper
Off	Off	100%
On	Off	75%
On	On	50%
Off	On	25%

**Table 37. Paper size detection switches**

Paper size	SW701	SW702	SW703	SW704
A3 (portrait)	On	On	Off	Off
A4 (landscape)	On	On	Off	On
B4 (portrait)	Off	Off	On	Off
Ledger (portrait)	Off	On	Off	Off
Legal (portrait)	Off	On	On	Off
Letter (landscape)	Off	On	Off	On

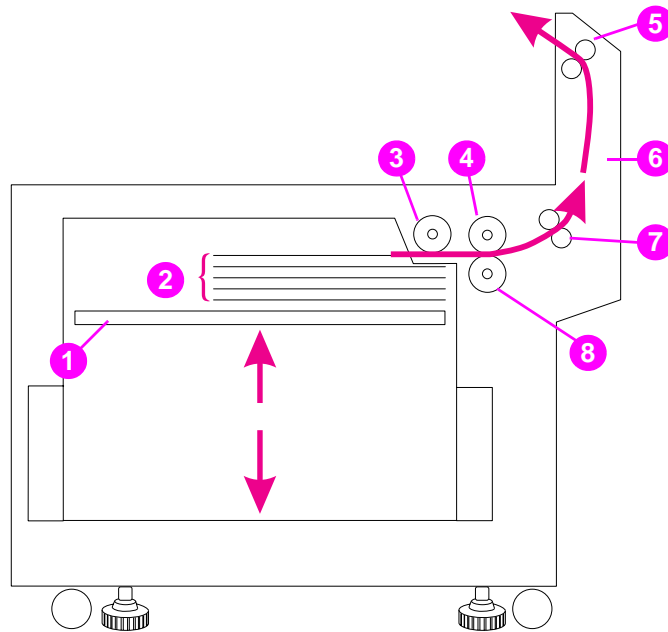
## Lifter operation

The lifting plate in the 2,000-sheet input unit is held by two wires that are wound on four pulleys by the lifter motor. When the paper tray is open, the pulley gears disengage from the lifter motor gears, and the lifting plate is lowered by its own weight. The presence or absence of the tray is detected by switches SW701 through SW704 on the unit paper/tray size switch assembly.

After the paper tray is closed, the lifter motor raises the paper stack into position; this action is detected by the PS34 sensor. The PS34 sensor also maintains the height of the paper stack. As paper is picked up by the rollers, the number of sheets decreases. Once the paper stack decreases to a certain level, the PS34 sensor registers a low condition. Then the paper deck driver turns on the lifter motor again and lifts the paper stack until the PS34 sensor registers sufficient paper in the tray.

## Paper path

Figure 65 illustrates the paper path components in the 2,000-sheet input unit.



**Figure 65.** 2,000-sheet input unit paper path

- |   |                |   |                              |
|---|----------------|---|------------------------------|
| 1 | Lifting plate  | 5 | Upper VTU rollers            |
| 2 | Paper stack    | 6 | Vertical transfer unit (VTU) |
| 3 | Pick-up roller | 7 | Lower VTU rollers            |
| 4 | Feed roller    | 8 | Separation roller            |

## Multi-bin mailbox

The multi-bin mailbox is an output unit designed for variable speeds, from 6 to 32 ppm. The multi-bin mailbox holds up to 2,100 sheets distributed in eight 250-sheet face-down bins and one 100-sheet face-up bin.

### Operating modes

The multi-bin mailbox features four intelligent and configurable operating modes.

- **Mailbox mode** — The network administrator can address each bin as an output destination with a name assigned to it. The printer sends a print job to the selected bin. If the assigned bin is full, the printer stops printing.
- **Job separator mode** — Each print job (or copy, if printing multiple original copies) is placed in a separate bin. All multi-bin mailbox bins are used for this purpose, starting with the first face-down bin (at the top). If a multi-bin mailbox bin is full, the printer automatically sends the job to the next available bin. If there are more jobs than bins, the extra jobs will start again at the top face-down bin. This process is seen in the printer software as one logical bin.
- **Virtual stacker mode** — Printed sheets are stacked face down in the bins from the lowest bin to the top bin, regardless of where a print job begins or ends. All printed sheets are sent to the bottom bin until it is full; subsequent sheets are sent to the next upward bin until it is full. This mode of operation takes advantage of the total capacity of the multi-bin mailbox bins. In this mode, the software sees the multi-bin mailbox as one logical bin. When the multi-bin mailbox is full, the printer stops sending paper until all the bins are emptied.

## Configuring operating modes

The network administrator chooses the mode of operation through an HP network configuration utility, such as the HP JetAdmin software or the HP LaserJet utility for the Macintosh. Additionally, on all workstations that print to the printer, the printer driver might need to be set up to reflect the chosen operating mode.

- **Bidirectional environment** — The printer automatically selects the mode established by the network administrator.
- **Unidirectional environment** — The mode of operation can be changed in the driver to reflect the current multi-bin mailbox settings. The method for changing the mode varies with the driver and type of operating system. For additional information, see the online help for the printer software.

## Power-on sequence

During the power-on sequence, the delivery head assembly moves first to the top “home” position at the face-up bin. From that position the delivery head moves down, scanning to determine if all the multi-bin mailbox bins are installed, if they contain paper, and if they are full. Then the delivery head proceeds upward again to the home position and remains there for about 7 seconds. Finally, the delivery head assembly moves to the bottom bin, where it waits for the next command from the EPH controller board.

---

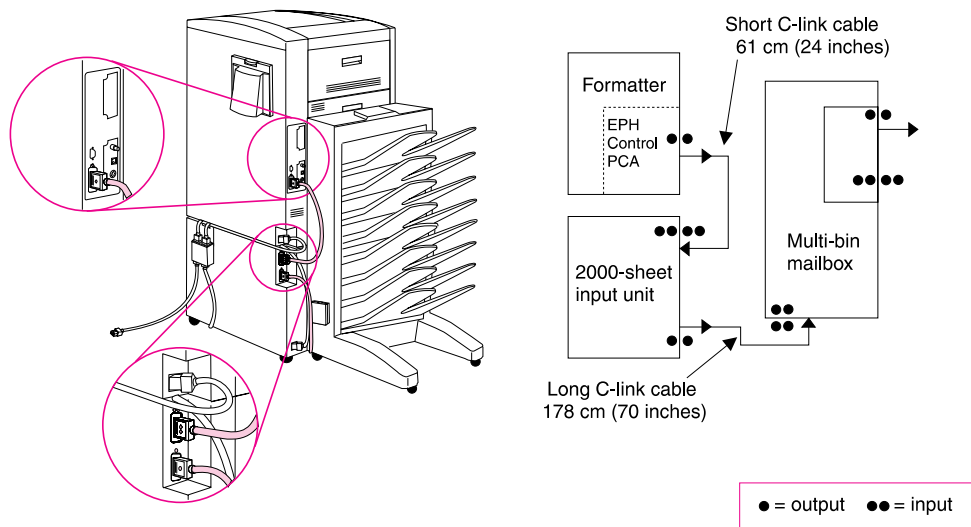
### Note

If one of the bins has been removed or is not seated correctly, the delivery head assembly will not complete the scan and will send an error message to the printer control panel.

---

## Communication link (C-link) cables

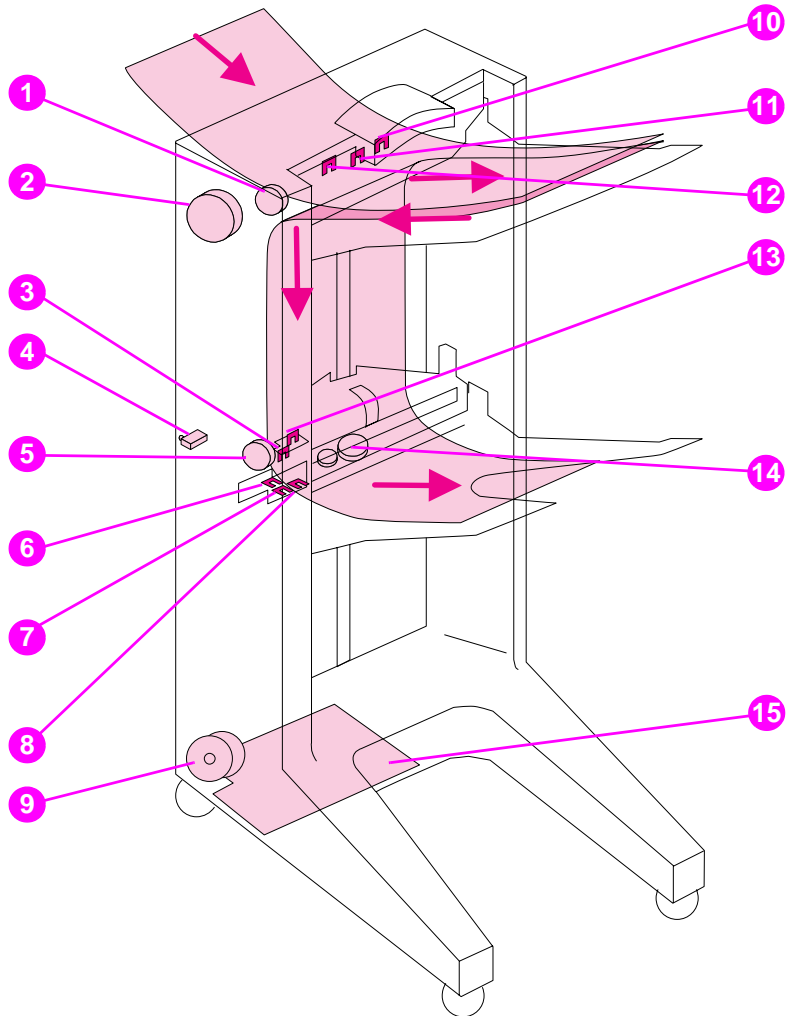
Communication with the multi-bin mailbox is handled through the EPH controller board on the printer. The information coming from the EPH controller board is carried by the C-link cables that connect the EPH controller board PCA to all the devices that support the C-link protocol. Figure 66 shows the C-link connections.



**Figure 66.** Multi-bin mailbox cabling

## Sensors, switches, motors, and controller board PCA

Figure 67 and table 38 illustrate and describe the multi-bin mailbox sensors, switches, motors, and controller board PCA.



**Figure 67.** Multi-bin mailbox sensors

**Table 38. Multi-bin mailbox sensors, switches, motors, and controller board PCA**

<b>Ref.</b>	<b>Control device</b>	<b>Description</b>
1	M2	Flipper roller motor with encoder
2	M1	Delivery head motor
3	PSEject	Delivery rollers extended sensor
4	SW1	Interlock switch
5	M3	Delivery head roller motor
6	PSBinFull/Head Position	Paper bin (below) is full sensor
7	PSBinEmpty	Paper bin empty sensor
8	PSExit2	Paper delivered to bin sensor
9	M5	Transport belt motor
10	PSFaceUp	Reverse stepper motor sensor
11	PSFaceFull	Left (face-up) output bin full sensor
12	PSEntry	Paper entry sensor
13	PSExit1	Paper delivered to head sensor
14	M4	Ejector motor
15		Controller board PCA

## Receiving paper

The printer delivers paper to the multi-bin mailbox through the face-up delivery slot (input paper guide) at a rate of 107 mm per second. Paper arrival is sensed by the PSEntry sensor, which activates the flipper roller motor (M2), causing the paper to move through the multi-bin mailbox transport and delivery system.



## Delivering paper

The delivery head assembly on the multi-bin mailbox moves or stays in the indicated bin according to the commands coming from the EPH controller board on the printer. If paper is designated for the face-up bin, the multi-bin mailbox feeds it through the flipper assembly. If paper is designated for one of the face-down output bins, the multi-bin mailbox feeds it through the flipper assembly until the trailing edge is sensed by the PSFaceUp sensor. Then the flipper roller motor (M2) reverses and feeds the paper down between the transport belt and the metal tape until it reaches the delivery head assembly.

## Paper path

Figure 68 illustrates the components of the multi-bin mailbox paper path.

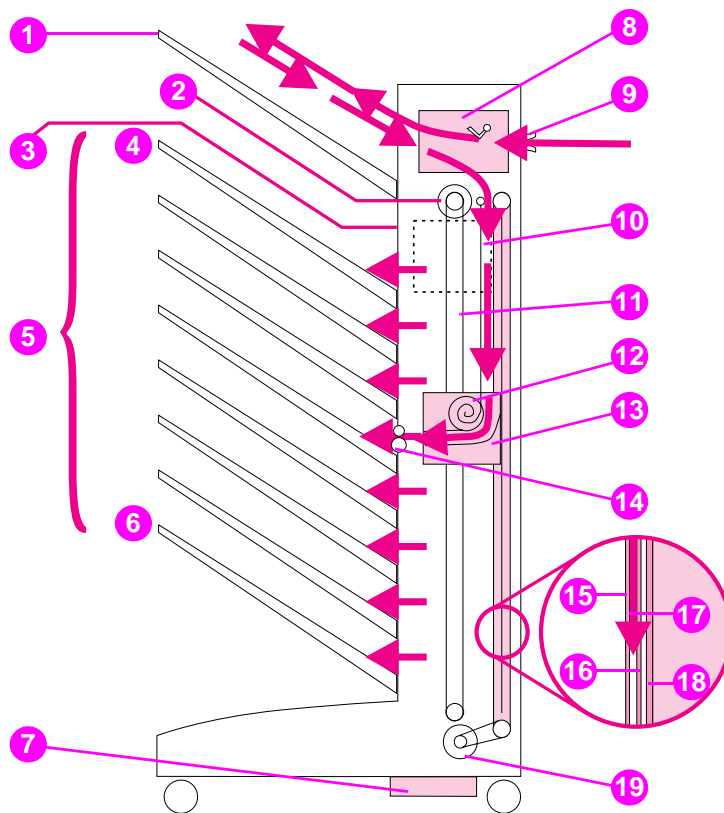


Figure 68. Multi-bin mailbox paper path

- |                               |                                  |
|-------------------------------|----------------------------------|
| <b>1</b> Face-up bin          | <b>11</b> Delivery head line     |
| <b>2</b> Delivery head motor  | <b>12</b> Metal tape             |
| <b>3</b> Blind cover          | <b>13</b> Delivery head assembly |
| <b>4</b> Bin 1                | <b>14</b> Eject rollers          |
| <b>5</b> Face-down bins       | <b>15</b> Metal tape             |
| <b>6</b> Bin 8                | <b>16</b> Transport belt         |
| <b>7</b> Controller board PCA | <b>17</b> Paper                  |
| <b>8</b> Flipper assembly     | <b>18</b> Magnetic strip         |
| <b>9</b> Input paper guide    | <b>19</b> Transport belt motor   |
| <b>10</b> Home position       |                                  |

## Duplexer

The duplexer is installed, below the fusing assembly. The back side of the paper is printed first. Then the paper is turned over and fed back through the paper path to print on the front side. The duplexer supports variable engine input speeds.

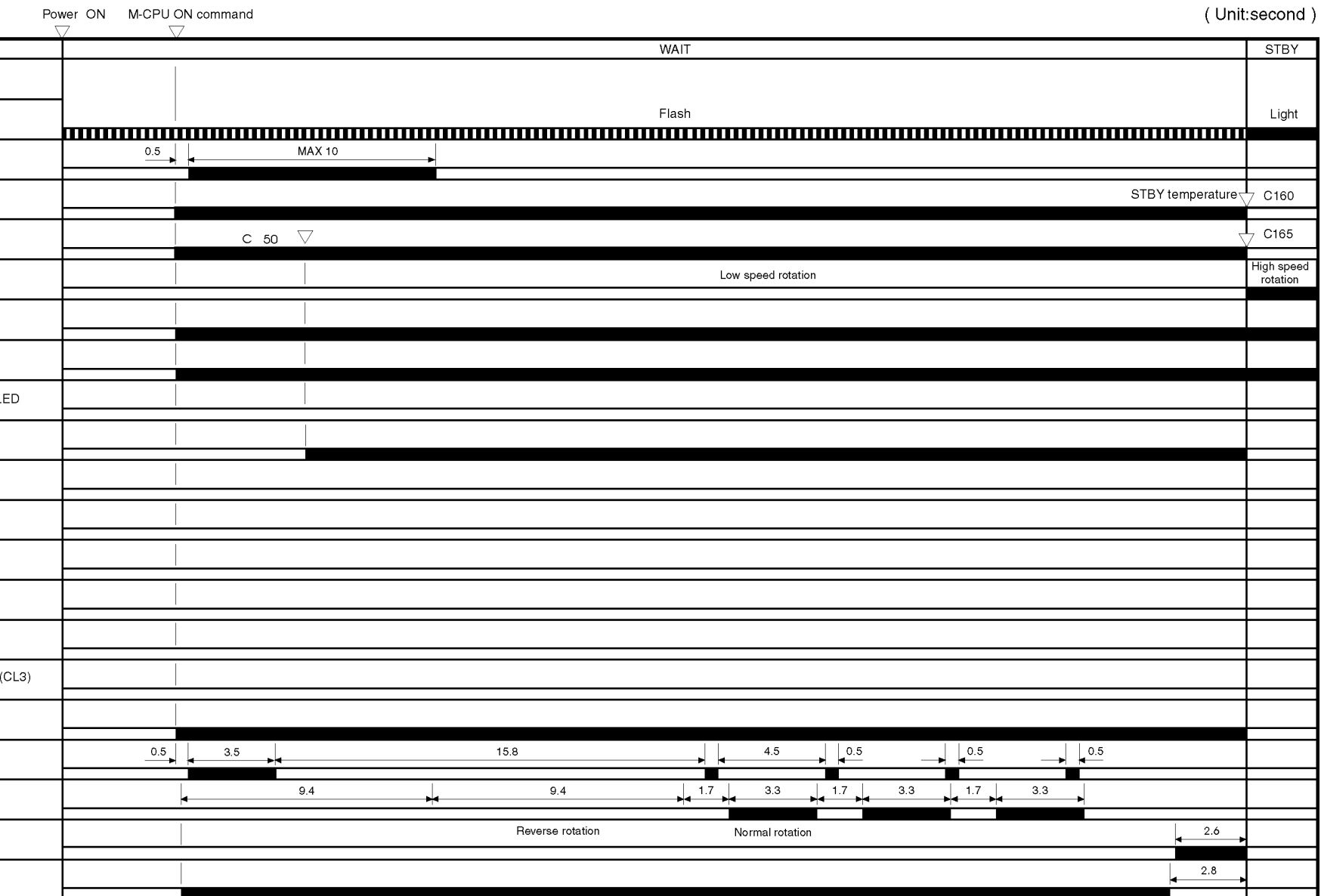
## Printer timing

The formatter PCA and controller board PCA share information during the printer operation. This information consists of printer status, command, and dot-image data. Figures 69 through 74 show the timing of different printer events.

period - 1/2

# I. GENERAL TIMING CHART

( Unit:second )



period - 2/2

Power ON

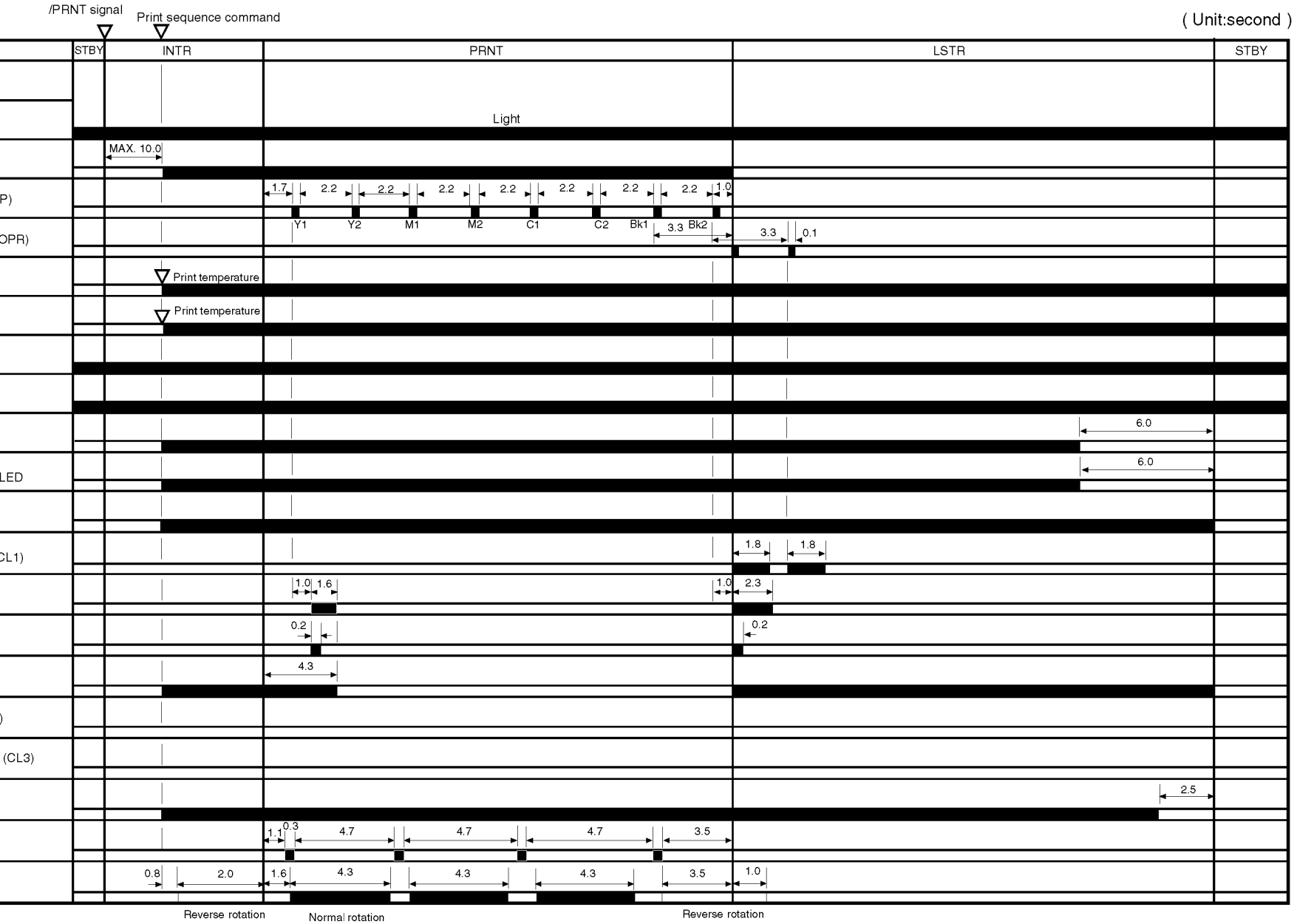
M-CPU ON command

( Unit:second )

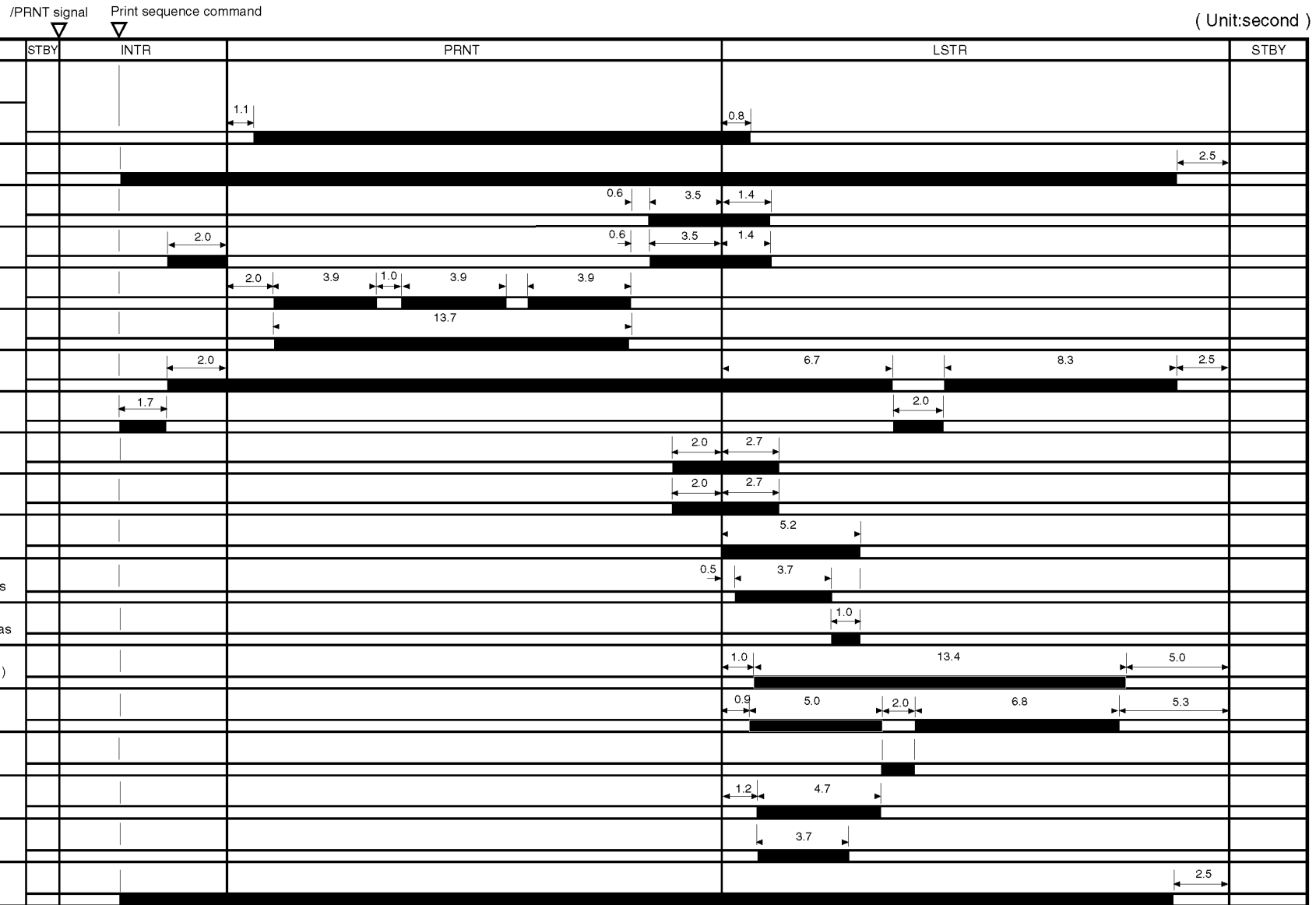


Timing chart for WAIT period (2 of 2)

Timing chart for printing LTR sheet (full color) -1/2

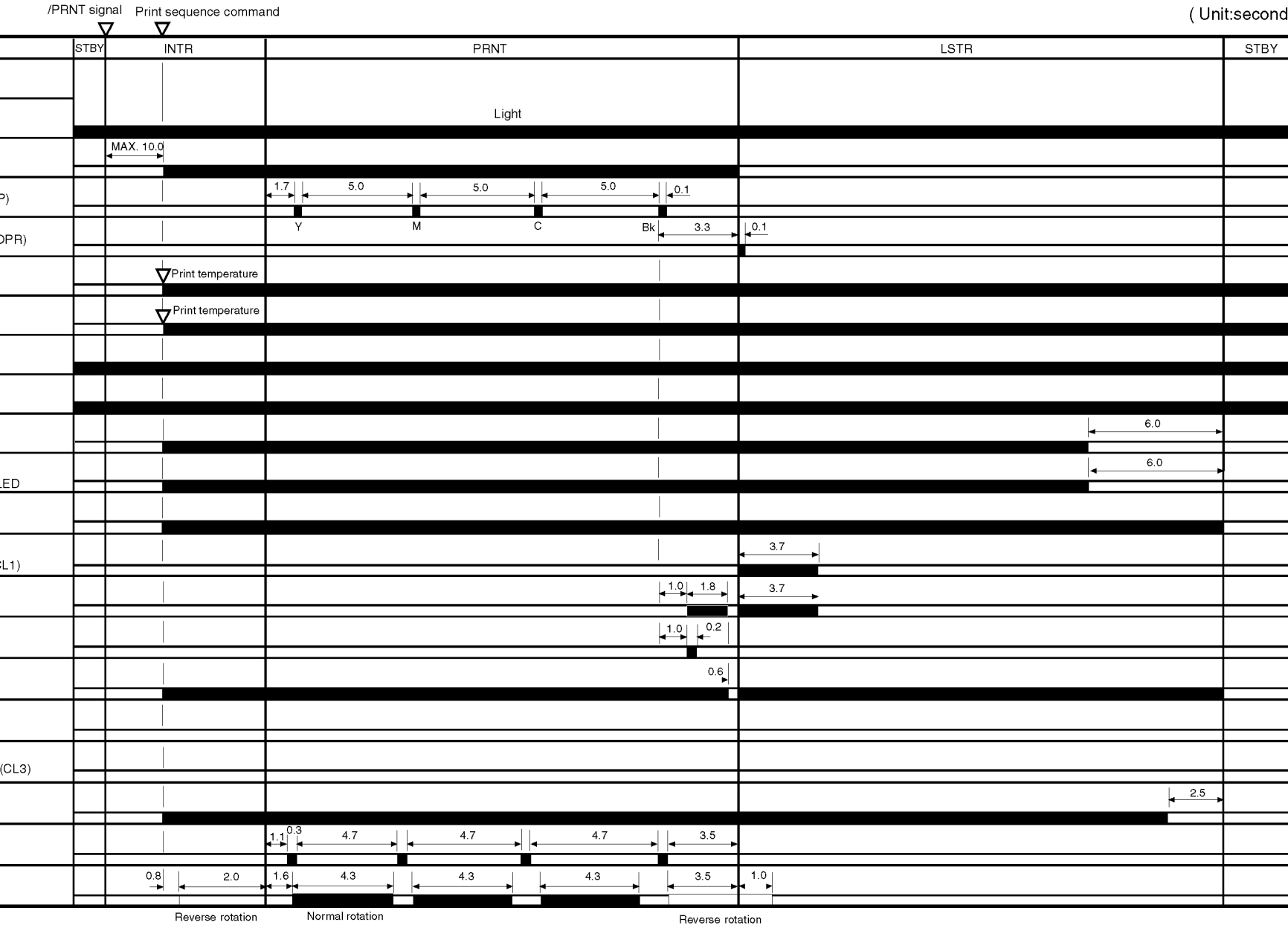


Timing chart for printing LTR sheet (full color) -2/2



Timing chart for printing LDR sheet (full color) - 1/2

( Unit:second )



Timing chart for printing LDR sheet (full color) - 2/2



Timing chart for printing full color 11-by-17 inch sized page (2 of 2)



# 6 Removal and replacement

## Chapter contents

Introduction . . . . .	203
Removal and replacement strategy . . . . .	203
Repair notices . . . . .	203
Electrostatic discharge (ESD) . . . . .	203
Required tools . . . . .	204
Maintenance units . . . . .	205
Doors and covers . . . . .	206
Front covers and panels . . . . .	208
Top cover assembly . . . . .	211
Left covers and doors . . . . .	213
Right covers and doors . . . . .	217
Rear cover . . . . .	222
Top assemblies . . . . .	223
Control panel . . . . .	223
Laser/scanner unit . . . . .	224
Face-down output assembly . . . . .	225
Front assemblies . . . . .	227
Toner lock sensor and color cartridge sensor . . . . .	227
Subrelay PCA . . . . .	228

Left assemblies . . . . .	229
Multi-bin mailbox . . . . .	229
Formatter board . . . . .	230
Internal printer hard disk (DN model). . . . .	232
Feeder assembly . . . . .	233
Face-up solenoid . . . . .	234
Face-up exit assembly . . . . .	236
Right assemblies . . . . .	237
Tray 1 . . . . .	237
Pick-up roller . . . . .	238
Registration roller assembly . . . . .	239
Paper photo (OHT) sensors . . . . .	241
Density sensor . . . . .	242
Paper pick-up assembly . . . . .	243
Tray 1 pick-up assembly . . . . .	244
Rear assemblies . . . . .	246
Formatter pan . . . . .	248
Fan 1 . . . . .	250
Fan 2 . . . . .	251
Power supply . . . . .	252
Controller board . . . . .	253
Cartridge motor (M3) . . . . .	254
Main motor (M4) . . . . .	255
Carousel motor PCA . . . . .	256
Carousel motor (M1) . . . . .	257
Delivery drive assembly . . . . .	259
Main gear assembly (not shown). . . . .	261
High-voltage converter 1 assemblies. . . . .	262
High-voltage converter 2 assemblies. . . . .	264
Main relay PCA . . . . .	266
Drum/cartridge drive assembly . . . . .	267
Separation discharge high-voltage converter assemblies. . . . .	268
Tray 2 and tray 3 media size sensing PCAs . . . . .	269

2,000-sheet input unit . . . . .	271
Front cover . . . . .	272
Back cover . . . . .	273
Left cover . . . . .	274
Vertical transfer unit (VTU) . . . . .	275
Right cover . . . . .	276
Tray 4 . . . . .	277
Paper pick-up assembly . . . . .	278
Controller PCA . . . . .	279
Front LED PCA assembly . . . . .	280
Power supply . . . . .	281
Main drive assembly . . . . .	282
Paper size sensor assemblies . . . . .	283
Tension springs . . . . .	285
Multi-bin mailbox . . . . .	286
Front and back covers . . . . .	287
Top cover . . . . .	288
Power supply . . . . .	289
Paper bins and blind cover . . . . .	290
Flipper assembly . . . . .	291
Delivery head position motor . . . . .	293
Transport belt motor . . . . .	294
Input paper guide . . . . .	295
Metallic tape and housing assembly . . . . .	297
Controller PCA . . . . .	299
Anti-curl strings . . . . .	301
Delivery head assembly . . . . .	303
Interlock switch . . . . .	306
Diagnostic LED PCA . . . . .	307
User status LED PCA . . . . .	308
Attachment assembly . . . . .	309



# Introduction

## Removal and replacement strategy

This chapter explains how to remove and replace major printer components.

Replacement is generally the reverse of removal. Occasionally, directions for difficult or critical replacement procedures are included.

## Repair notices

---

### WARNING!

Turn the printer off and disconnect the power cord before servicing the printer. Failure to follow this instruction could result in severe injury.

Never operate or service the printer with the protective cover removed from the scanner assembly. The reflected beam, although invisible, can damage your eyes.

The sheet-metal parts can have sharp edges. Be careful not to cut yourself when handling sheet-metal parts.

---

### CAUTION

Always protect the imaging drum from light and physical contact when removed from the printer. HP recommends reinstalling the original cover whenever the drum is removed from the printer.

## Electrostatic discharge (ESD)



The printer contains parts that are sensitive to electrostatic discharge (ESD). Watch for the ESD reminder shown at the left while removing printer parts. Protect the parts that are sensitive to ESD by using an ESD wrist strap and protective ESD pouches.

## Required tools

The following tools are needed to service the printer:

- Phillips #1 magnetized screwdriver, 6-inch (152-mm) shaft
- Phillips #2 magnetized screwdriver, 6-inch (152-mm) shaft
- T-10, T-15, and T-20 Torx driver, 6-inch (152-mm) shaft
- Flat-blade #2 screwdriver
- Small pair of needle-nose pliers
- ESD strap
- Penlight
- Can of compressed air

If you are using a multi-speed screwdriver, ensure that you have a torque limiter. Ensure that you have a Phillips screwdriver and not a Posidriv screwdriver.

---

### CAUTION

---

To install a self-tapping screw, first turn it counterclockwise to align it with the existing thread pattern. Then carefully turn it clockwise to tighten it. Do not over-tighten. If a self-tapping screw hole becomes stripped, either repair the screw hole or replace the affected assembly.

## Maintenance units

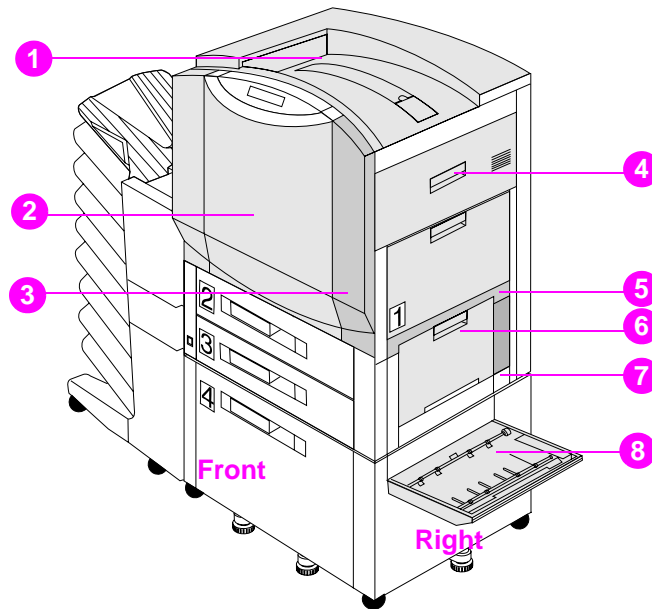
The user replaces the following maintenance units as part of periodic maintenance. Chapter 4 explains the maintenance procedures.

- Color toner cartridges
- Black toner cartridge
- Imaging drum
- Air filters
- Transfer drum
- Transfer belt
- Transfer charger
- Cleaning roller
- Charcoal filter
- Fuser
- Paper rollers

The printer keeps track of use on some of its user-replaceable parts. Because maintenance unit life is tracked by the formatter board by page count, swapping maintenance units between printers might cause a misrepresentation of maintenance unit life values.

## Doors and covers

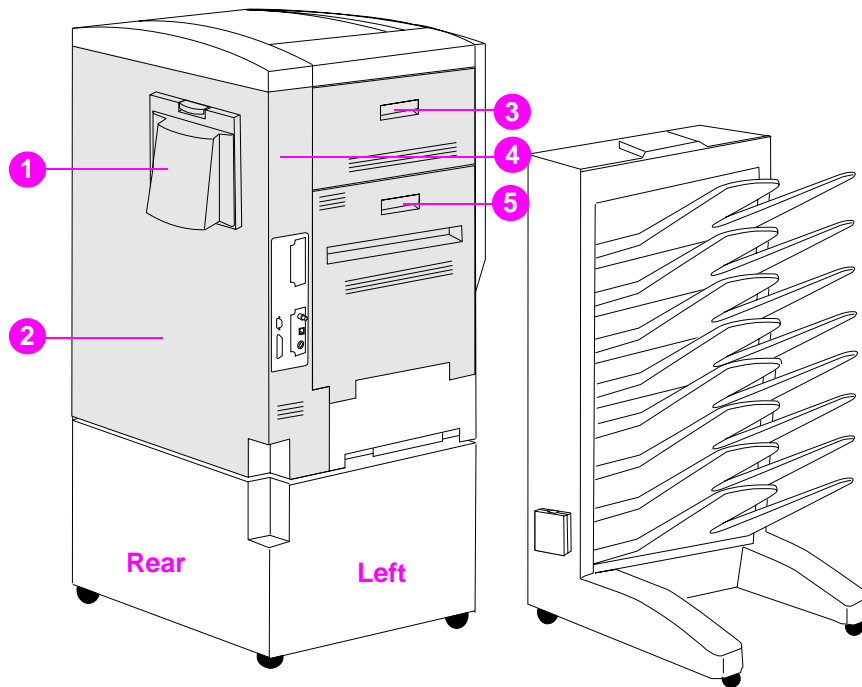
The following figures show the orientation of the printer and paper handling accessories as they are referred to in this chapter.



**Figure 75.** Orientation of printer and accessories: top, front, and right

- 1 Top cover assembly
- 2 Front cover
- 3 Front right cover
- 4 Right upper cover assembly (includes the right upper door)
- 5 Right cover subassembly
- 6 Right lower cover assembly (includes the right lower door)
- 7 Right rear cover
- 8 Vertical transfer unit (VTU)





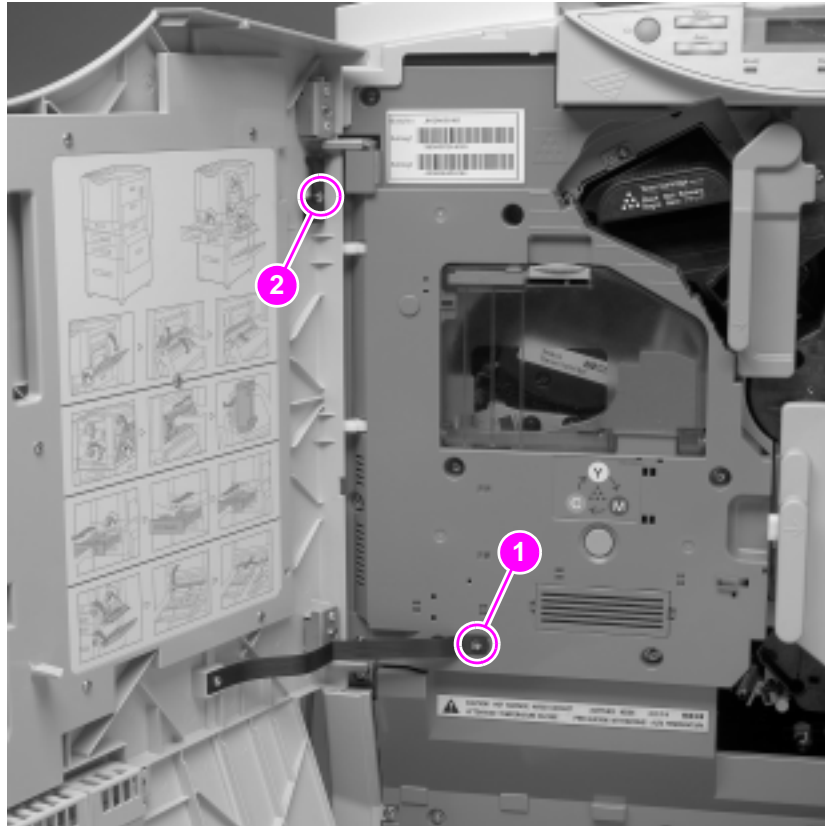
**Figure 76.** Orientation of printer and accessories: rear and left

- 1 Exhaust fan cover
- 2 Rear cover
- 3 Left upper cover (includes the left upper door)
- 4 Left rear cover
- 5 Left lower cover

## Front covers and panels

### Removing the front cover

- 1 Open the front cover.
- 2 Remove 1 screw holding the strap in place (callout 1).

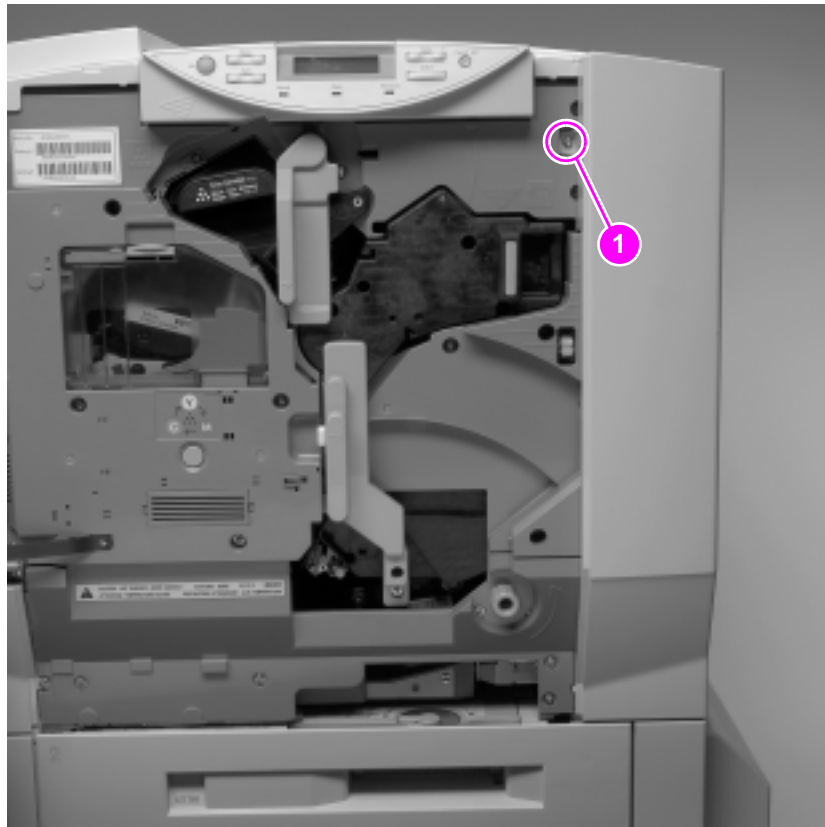


**Figure 77.** Removing the front cover

- 3 Remove 1 screw holding the cover (callout 2).
- 4 Open the cover to approximately a 45-degree angle and lift it up to remove it.

## Removing the front right cover

- 1 Open the front door.
- 2 Remove 1 screw in the upper right-hand side that holds the front right cover on (callout 1).

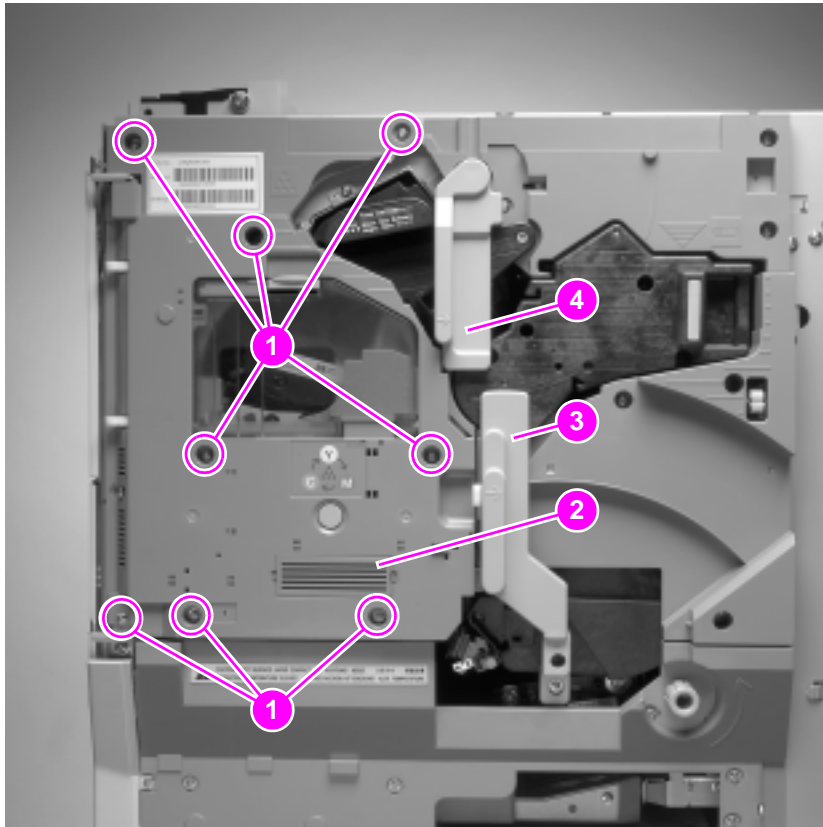


**Figure 78.** Front right cover

- 3 Pull the cover off.

## Removing the inside left panel

- 1 Remove the front cover (see page 208).
- 2 Remove the top cover assembly (see page 211).
- 3 Remove 8 screws on the inside panel (callout 1).



**Figure 79.** Inside left panel

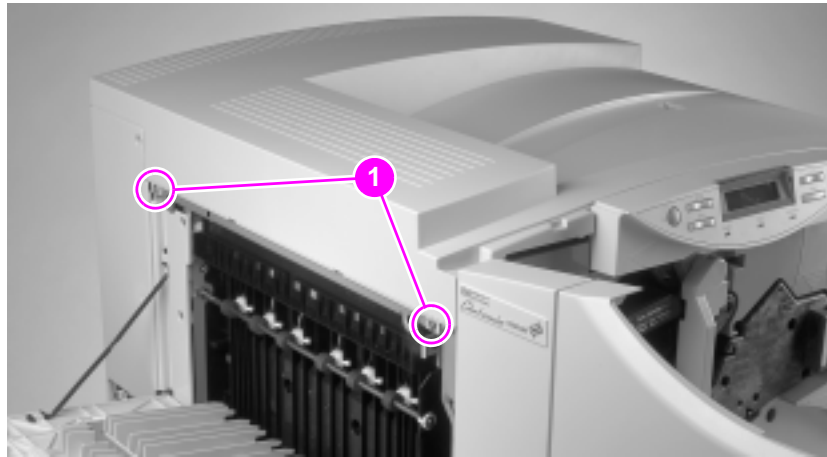
- 4 Remove the waste toner tray cover (callout 2) by releasing the tab on the right side of the cover with a small screwdriver.
- 5 Remove the waste toner tray.
- 6 Open the left lower door to disengage the interlock.
- 7 Swing both the lower green lever (callout 3) and the upper blue lever (callout 4) to the right.
- 8 Pull the panel off.

**Notes on reinstalling:**

- When replacing the inside left panel, the lower left door and the toner carousel door must be open so that the interlock engages.

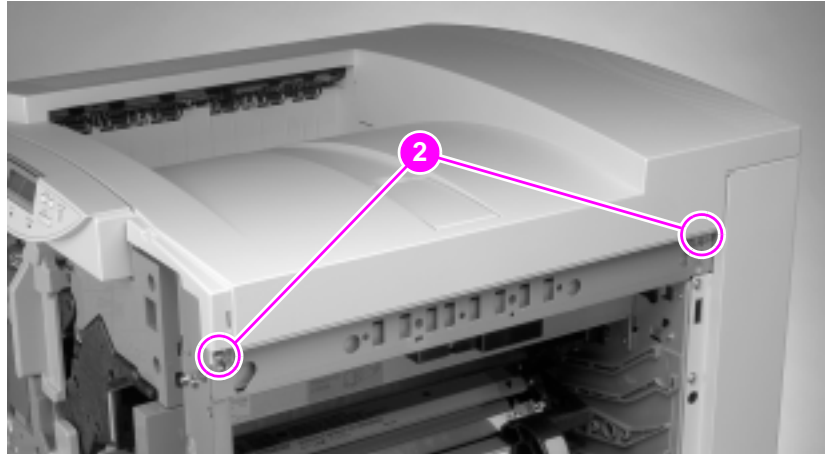
## Top cover assembly

- 1 Remove the front right cover (see page 209). Leave the front door open.
- 2 Open the left door and loosen the 2 screws (callout 1).



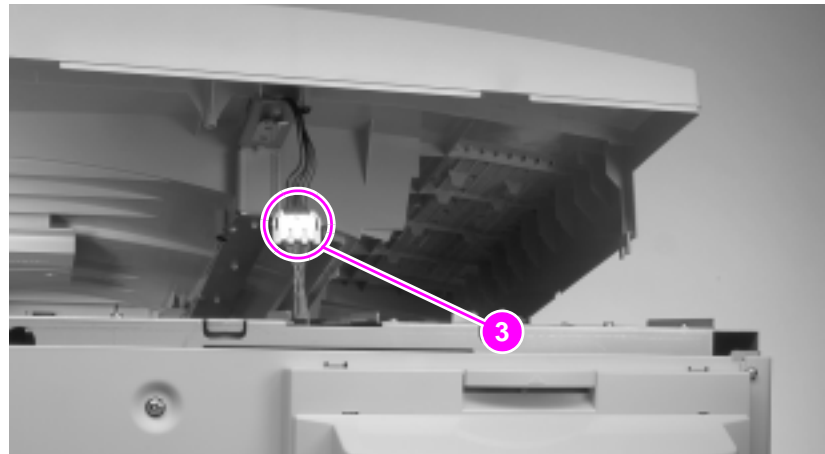
**Figure 80.** Screws behind left door

- 3 Open the right door and loosen the 2 screws (callout 2).



**Figure 81.** Screws behind right door

- 4 Open the front cover.
- 5 Lift the cover up and unplug the connector (callout 3) at the rear of the cover.



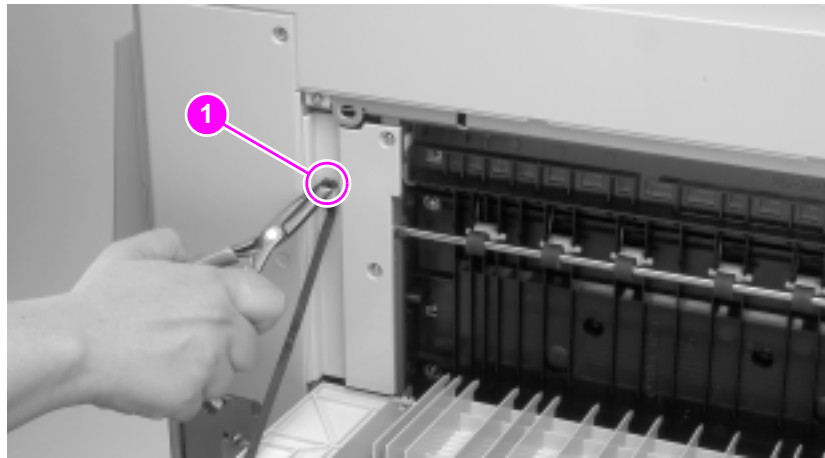
**Figure 82.** Connector on top cover

- 6 Remove the top cover assembly.

## Left covers and doors

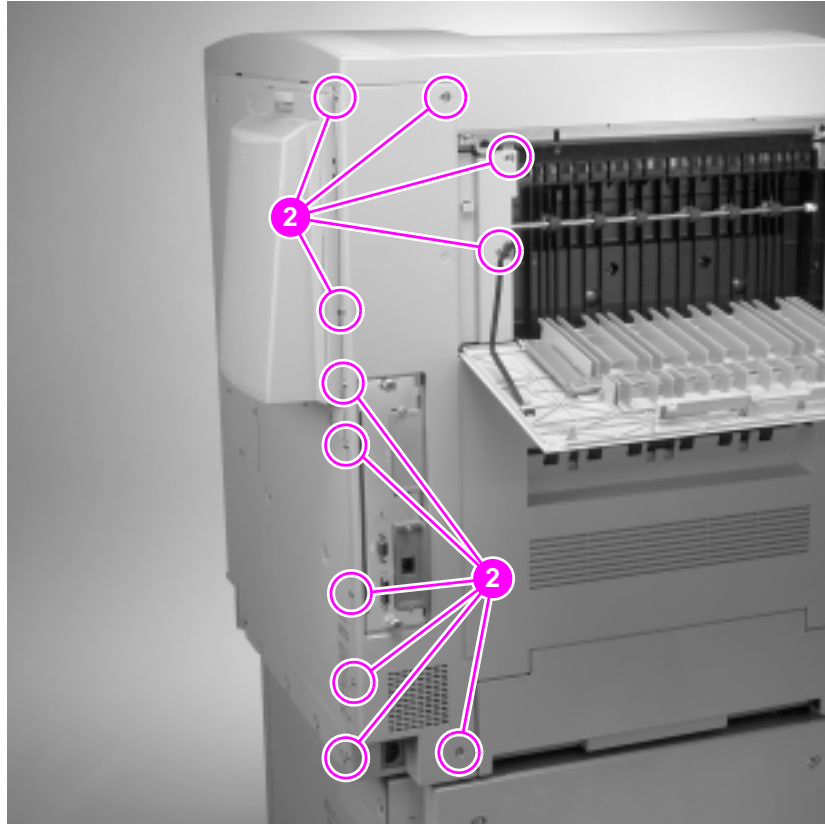
### Removing the left rear cover

- 1 Open the left upper door.
- 2 Support the door and squeeze the prong with needle-nose pliers to unhook the strap holding the door to the left rear cover (callout 1).



**Figure 83.** Left door and strap

3 Remove 11 screws (callout 2).



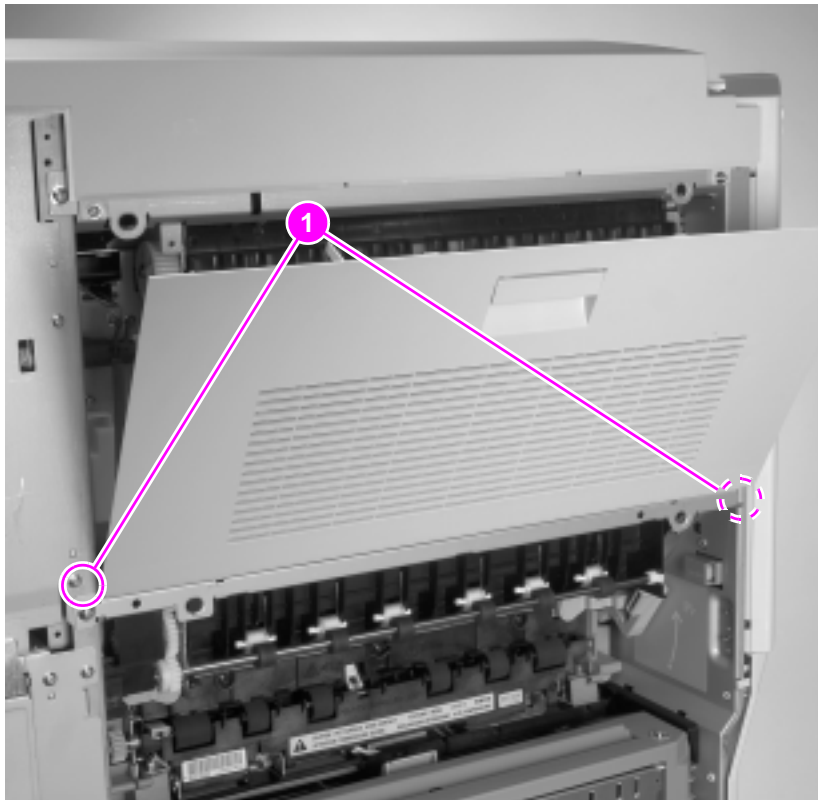
**Figure 84.** Screws on left rear cover

4 Pull the cover to the left and off.



## Removing the left upper cover

- 1 Remove the left rear cover (see page 213).
- 2 Remove 2 screws on the rail (callout 1, one screw is on the left side of the cover and the other is located inside the front cover).

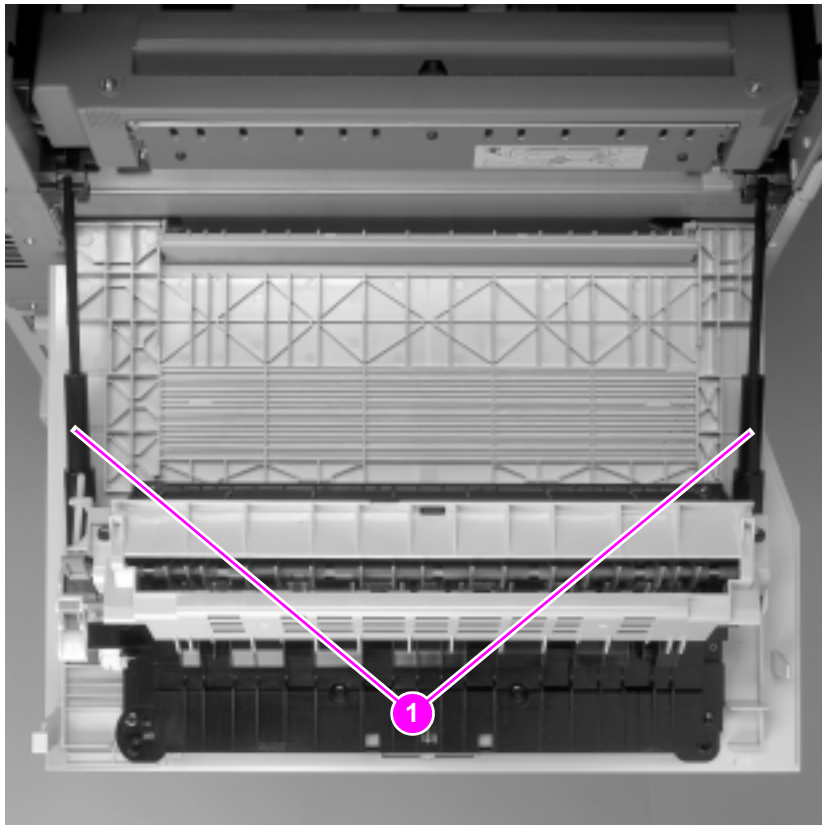


**Figure 85.** Screws on upper left door

- 3 Remove the door.

## Removing the left lower cover

- 1 Open the left lower cover.
- 2 Push the spring-loaded stopper hinges (callout 1) towards the printer and down to release them.



**Figure 86.** Stopper hinges on lower left cover

- 3 Move the cover to a 45-degree angle and lift the right side out.
- 4 Slide the cover to the left and up to release the left side.

## Right covers and doors

### Removing the right upper cover assembly

Tray 1 is part of the right upper door. Take the tray off and save it if you are replacing the whole assembly (see page 237). The new assembly does not include the tray.

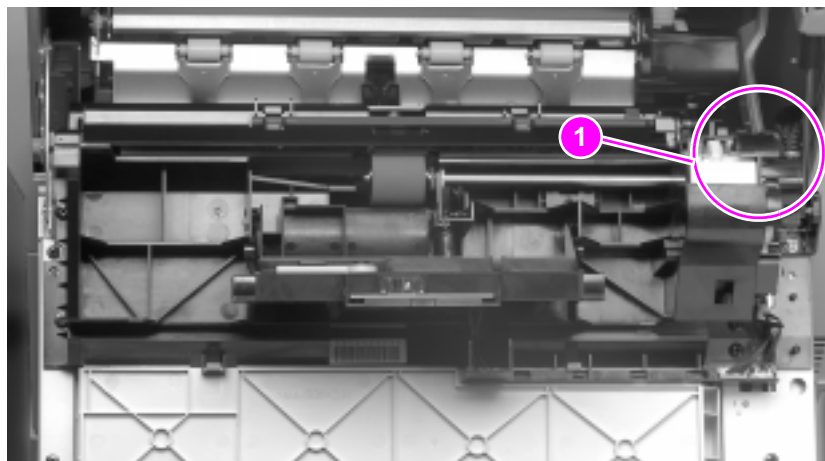
- 1 Remove the rear cover (see page 222).
- 2 Open the right upper door.
- 3 On the right side of the door, unplug 4 connectors that lead through the printer frame to the right upper cover (callout 1).

---

#### Note

Two connectors are plugged into the controller board, and two connectors are inline connectors. It might be easier to disconnect the connectors from the rear of the printer and pull the wires through the printer frame than to unplug the connectors from the right upper door.

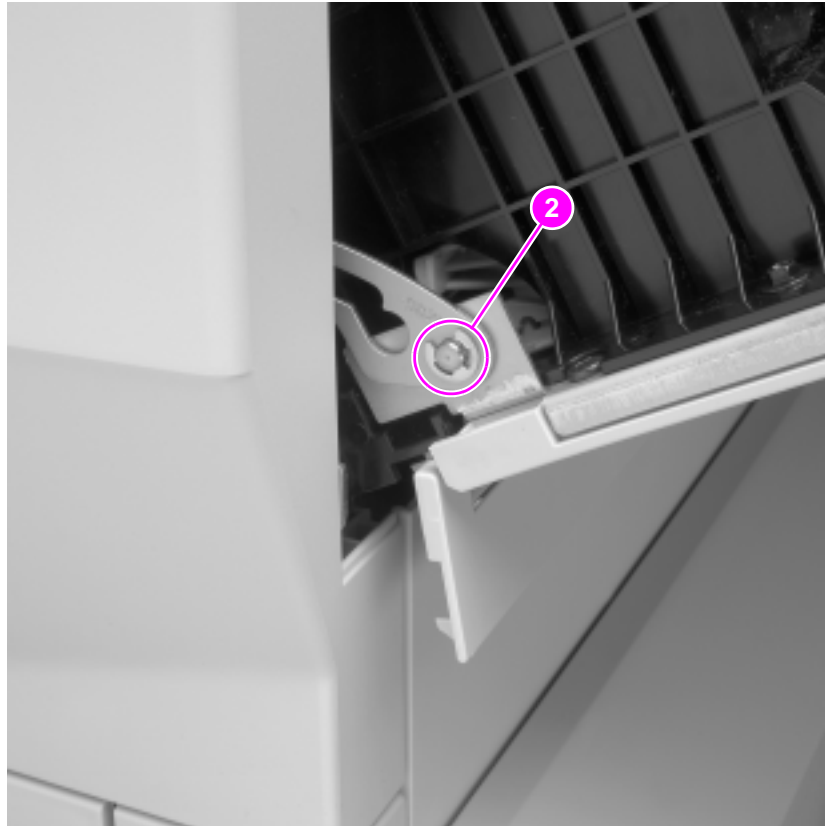
---



**Figure 87.** Connectors on the right upper door

- 4 Close the door to a 45-degree angle and release the spring-loaded hinges on the right side.

- 5 With needle-nose pliers, remove the e-ring from the hinge (callout 2) on the left side of the door.



**Figure 88.** E-ring

- 6 Remove the front right cover (see page 209).
- 7 Rotate the plastic tab (located on the left hinge) up to a 90-degree angle.
- 8 Lift the door slightly to the left and pull it away from the chassis.

## Removing the right cover subassembly

---

### Note

Use this procedure if you want to separate the right cover subassembly from the right upper cover.

- 1 Open the right upper cover assembly slightly.
- 2 Pull the right side of the subassembly slightly to the right and pull outward on the right side to snap it out of place.
- 3 Move the subassembly slightly to the left and to remove it.

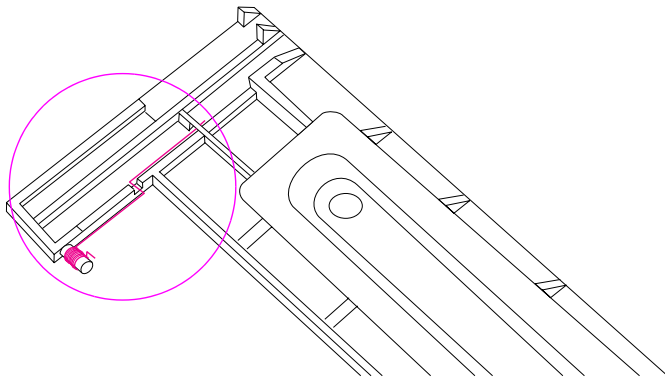
---

### Note

There is a small spring on the left side of the subassembly—be careful it does not fall off.

### Notes on reinstalling:

- If the spring falls off the subassembly, slide it onto the pin and through the slot on the left side of the subassembly.



**Figure 89.** Spring on right cover subassembly

## Removing the right rear cover

- 1 If you have a 2,000-sheet input unit, open the vertical transfer unit (VTU).
- 2 Remove one screw (callout 1).

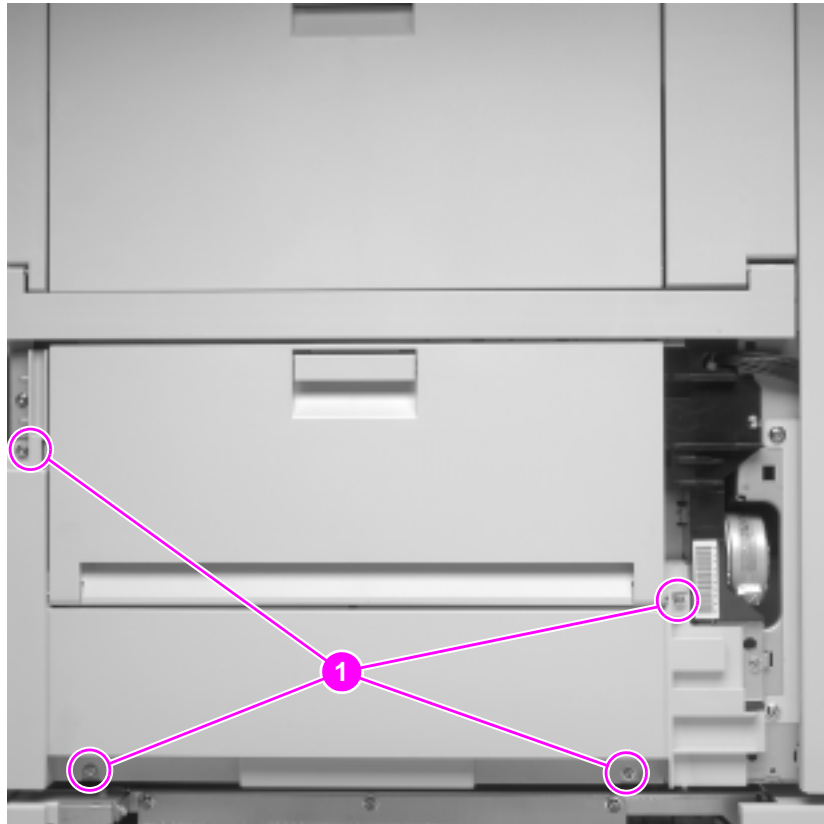


**Figure 90.** Right rear cover

- 3 Pull the bottom of the cover out and then down to remove the cover.

## Removing the right lower cover assembly

- 1 Remove the front right cover (see page 209).
- 2 If you have a 2,000-sheet input unit, open the VTU.
- 3 Remove the right rear cover (see page 220).
- 4 Remove 4 screws on the right lower cover in place (callout 1).



**Figure 91.** Screws on the right lower cover

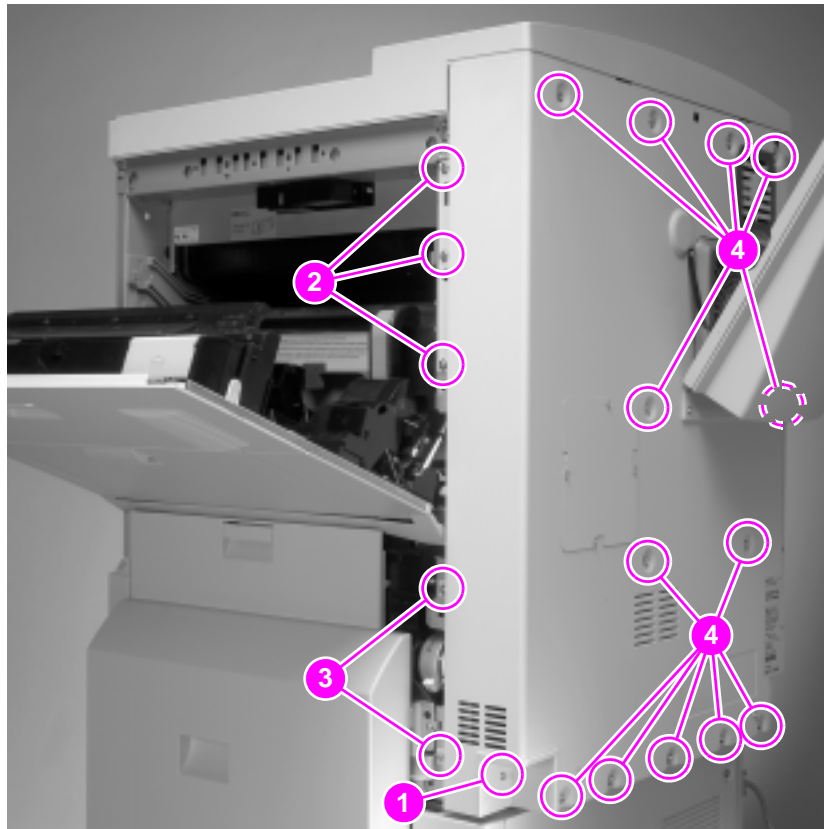
- 5 Unfasten the holding strap on the right.
- 6 Remove tray 2 and tray 3, and release the locking tabs inside the tray 3 area.
- 7 While holding the cover in place, push down to release the tabs on the top of the cover and pull out on the bottom of the cover.

### Notes on reinstalling:

- Insert the tabs on the top of the cover in the corresponding holes first, then snap the bottom of the cover into place.

## Rear cover

- 1 Remove the rear lower left cover (1 screw) (callout 1).



**Figure 92.**

### Rear cover

- 2 Remove the left rear cover (see page 213).
- 3 Open the right upper door.
- 4 Remove 3 screws on the right in the sheet metal tab (callout 2).
- 5 Remove the right rear cover (see page 220).
- 6 Remove 2 screws (callout 3).
- 7 Remove 13 screws on the rear cover (callout 4).

---

#### Note

Two screws are holding the cover to the hinges at the bottom. It is not necessary to remove these screws.

---

- 8 Lift the rear cover off.



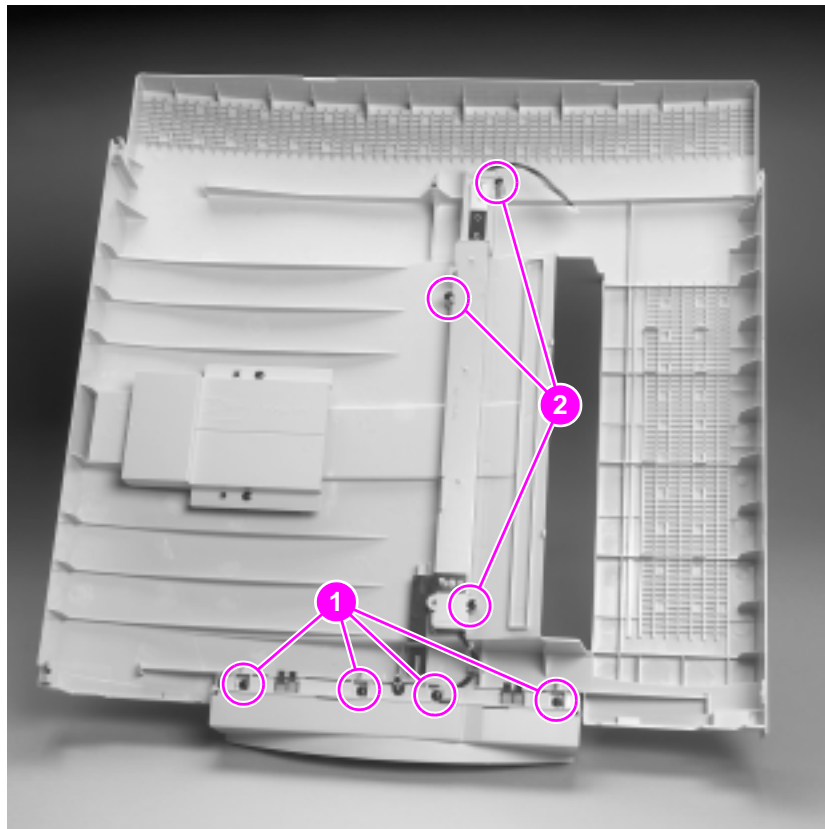
## Top assemblies

The following assemblies are accessed from the top of the printer:

- control panel
- laser/scanner unit
- face-down output assembly

### Control panel

- 1 Remove the top cover assembly (see page 211).
- 2 Turn the cover upside down.
- 3 Remove 4 screws attaching the control panel to the top cover (callout 1).

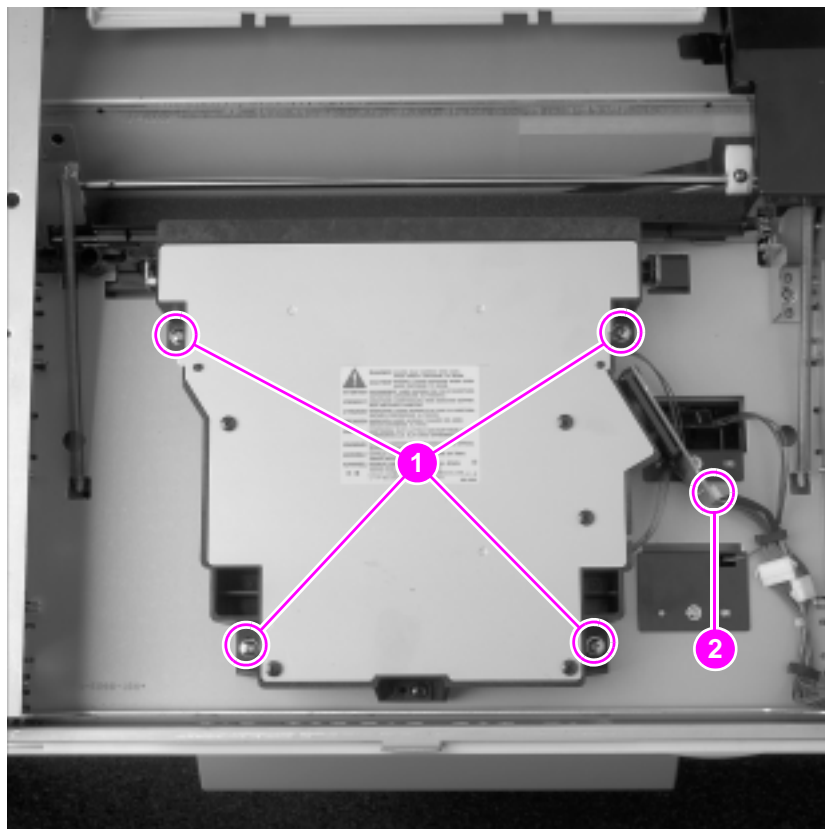


**Figure 93.** Bottom of the control panel

- 4 Remove 3 screws from the bar on the bottom of the control panel that is holding the wires in place (callout 2).
- 5 Release the cable stays.
- 6 Remove the assembly.

### Laser/scanner unit

- 1 Remove the top cover assembly (see page 211).
- 2 Remove 4 screws (callout 1).

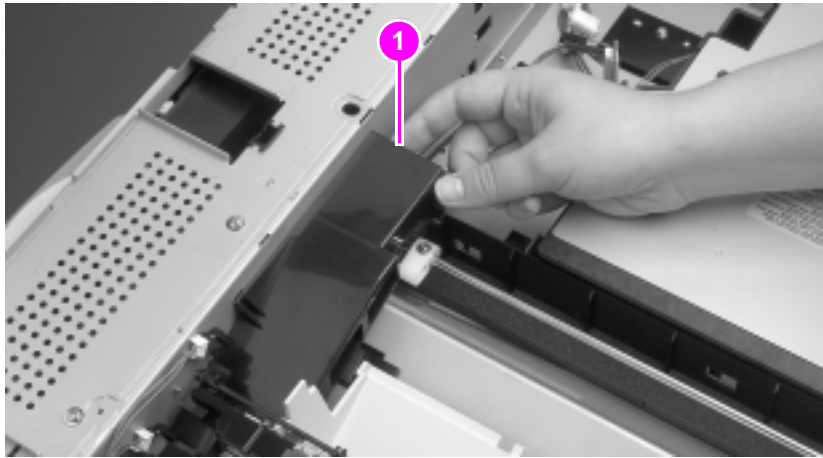


**Figure 94.** Scanner unit

- 3 Release the wires from the cable stay.
- 4 Unplug the 2 connectors (callout 2).
- 5 Gently remove the laser/scanner unit and place it in an ESD pouch.

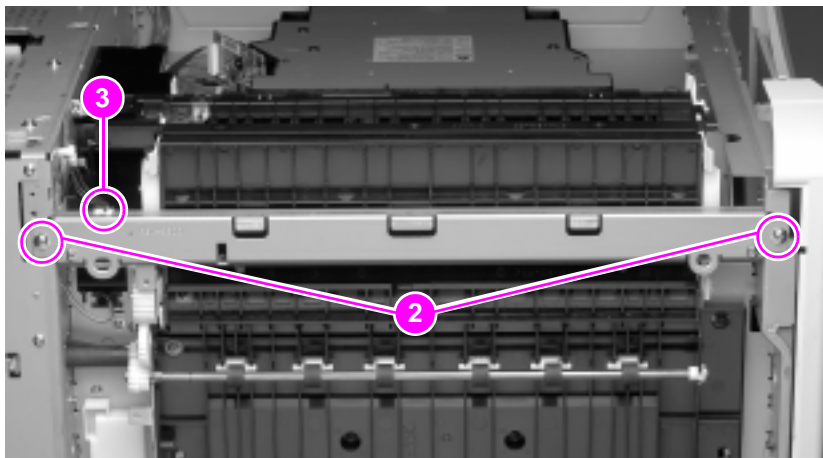
## Face-down output assembly

- 1 Remove the top cover assembly (see page 211).
- 2 Remove the left rear cover (see page 213).
- 3 Remove the left upper cover (see page 215)
- 4 On the top of the printer, remove the black airflow vent by releasing the cut tab (callout 1) and lifting the vent off.



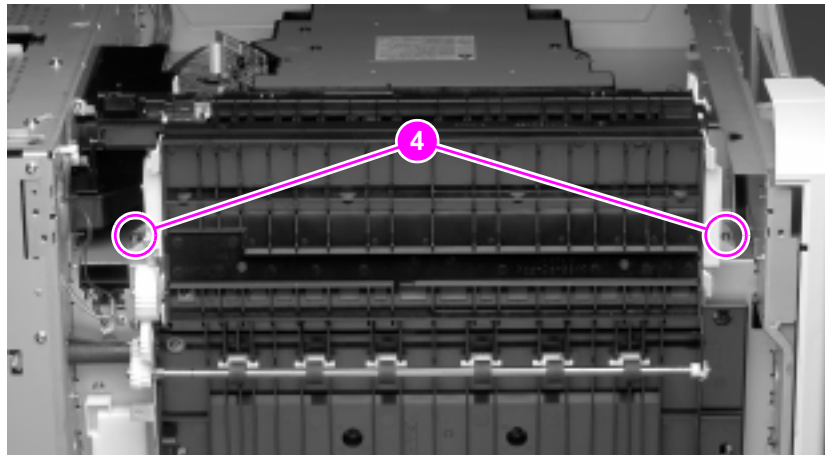
**Figure 95.** Upper airflow vent

- 5 Remove 2 screws on the face-down exit sensor rail (callout 2).



**Figure 96.** Face-down exit sensor rail

- 6 Unplug the sensor connector on the left side of the rail and release 1 cable stay (callout 3).
- 7 Pull the rail away from the chassis.
- 8 Remove 2 screws (callout 4).



**Figure 97.** Face-down output assembly

- 9 Lift the right side of the assembly, slide the assembly to the left, and lift it out of the chassis.

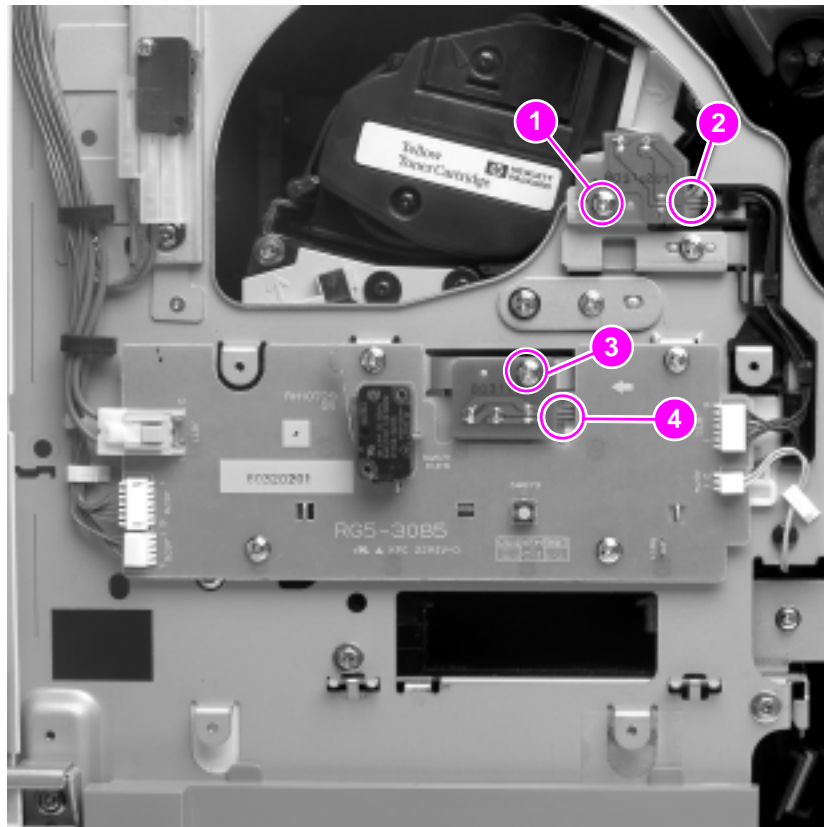
## Front assemblies

The following assemblies can be accessed from the front of the printer:

- toner lock sensor
- color cartridge sensor
- subrelay PCA

### Toner lock sensor and color cartridge sensor

- 1 Remove the inside left panel (see page 210).
- 2 Remove 1 screw on the toner lock sensor (callout 1).



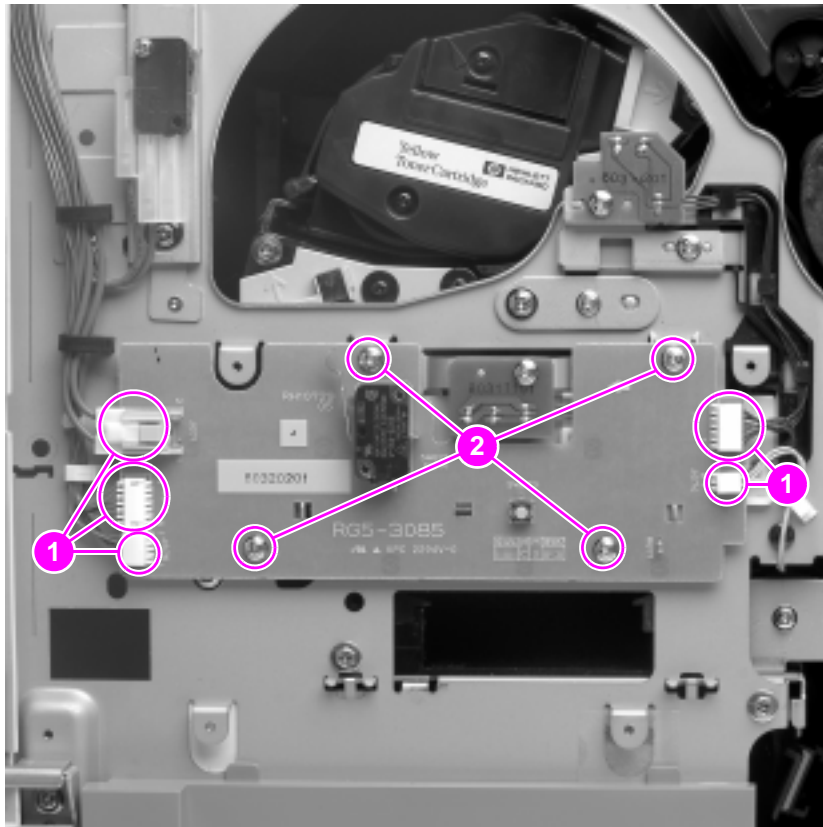
**Figure 98.** Toner lock sensor and color cartridge sensor

- 3 Remove 1 connector (callout 2).
- 4 Remove 1 screw on the color cartridge sensor (callout 3).

- 5 Remove 1 connector (callout 4).

### Subrelay PCA

- 1 Remove the inside left panel (see page 210).
- 2 Remove the 5 connectors on the subrelay PCA (callout 1).
- 3 Remove 4 screws on the subrelay PCA (callout 2).



**Figure 99.** Subrelay PCA

## Left assemblies

The following assemblies can be accessed from the left side of the printer:

- formatter board
- internal printer hard disk
- feeder assembly
- face-up solenoid
- face-up exit assembly

### Multi-bin mailbox

Remove the optional multi-bin mailbox before beginning repairs on the left side of the printer.

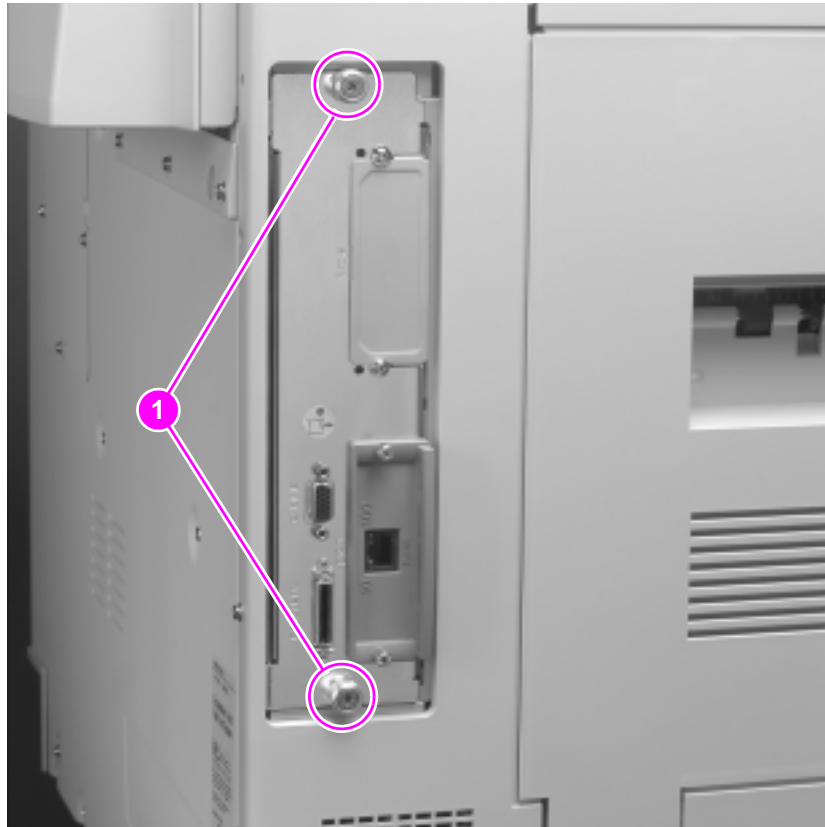
- 1 Turn the printer off and unplug the power cable.
- 2 Unplug the multi-bin mailbox power cable from the printer.
- 3 Unplug the multi-bin mailbox interface cable from the printer.
- 4 Holding the multi-bin mailbox by the handle on the top and by the main body towards the bottom, pull the mailbox away from the printer.
- 5 Push down on the end of the guide rail until it releases from the bracket on the 2,000-sheet input unit.
- 6 Raise the guide rail.

## Formatter board

If the formatter board needs to be repaired or replaced, remove the hard drive and retain it to reattach to the formatter board later.



- 1 Print a configuration page if the printer is able to generate one (see page 361). Use this page to reset the NVRAM values that will be lost if the formatter board is replaced.
- 2 Loosen the 2 finger screws (callout 1).



**Figure 100.** Formatter board

- 3 Pull the formatter board out of the formatter pan. Removing the formatter board from the formatter pan disconnects the formatter board from the chassis.



**Notes on reinstalling:**

- After reinstalling the formatter board, print a configuration page to compare with the configuration page printed before the formatter board was removed. Look at the following NVRAM values, and reset the NVRAM values to match those on the configuration page that was printed before the formatter board was removed.
  - Serial number
  - Formatter number
  - Page counts (if the controller board is being replaced as well)
  - Transfer kit count (percentage of life remaining)
  - Fuser kit count (percentage of life remaining)
  - Engine settings

---

**Note**

---

The last two digits of the engine settings might vary from those found on the sticker inside the front cover. This difference is due to check sum variation and is acceptable.

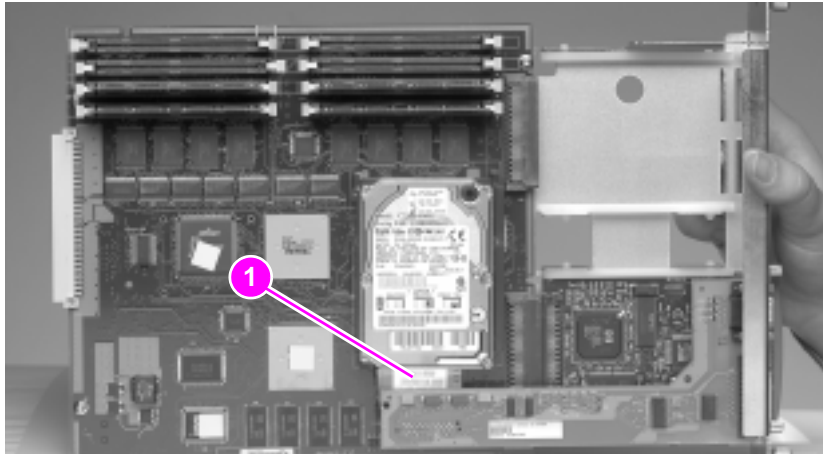
For information on setting each of these values, see table 21 on page 80.

## Internal printer hard disk (DN model)

If the internal printer hard disk needs to be repaired or replaced, all data stored on the hard disk will be lost. Download fonts and other information as necessary.

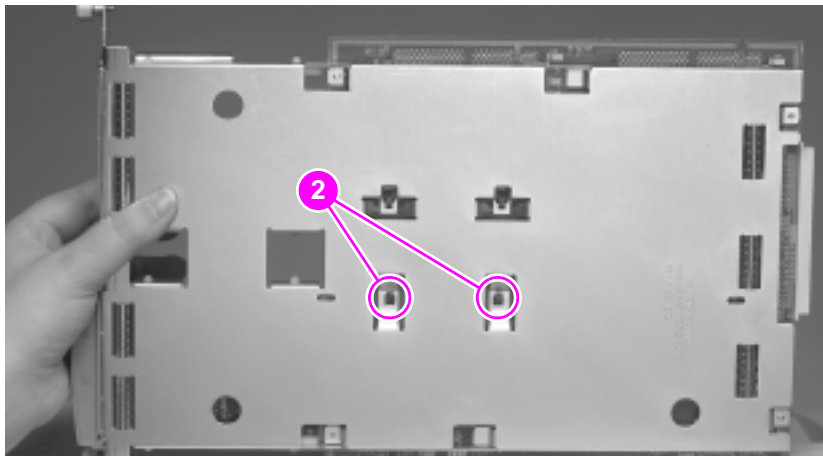


- 1 Remove the formatter board from the printer (see page 230).
- 2 Unplug 1 connector (callout 1).



**Figure 101.** Connector on formatter board

- 3 On the back side of the formatter board, release the 2 tabs with your fingers (callout 2).



**Figure 102.** Back side of formatter board

- 4 With the other hand, pull the hard disk out from the other side.

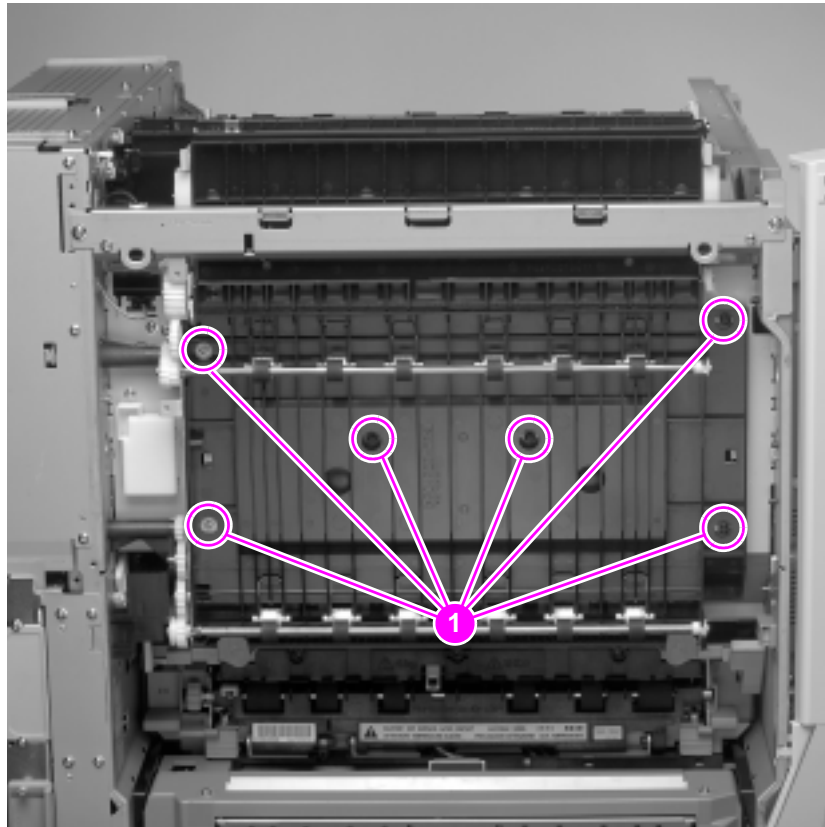
**CAUTION**

Take care not to damage the plastic retaining clips on the hard disk.

## Feeder assembly

The feeder assembly is located inside the left upper door.

- 1 Open the front door, and the left lower cover.
- 2 Remove the left rear cover (see page 213).
- 3 Remove the left upper cover (see page 215).
- 4 Remove 6 screws (callout 1).



**Figure 103.** Feeder assembly

- 5 Lift the feeder assembly up and out.

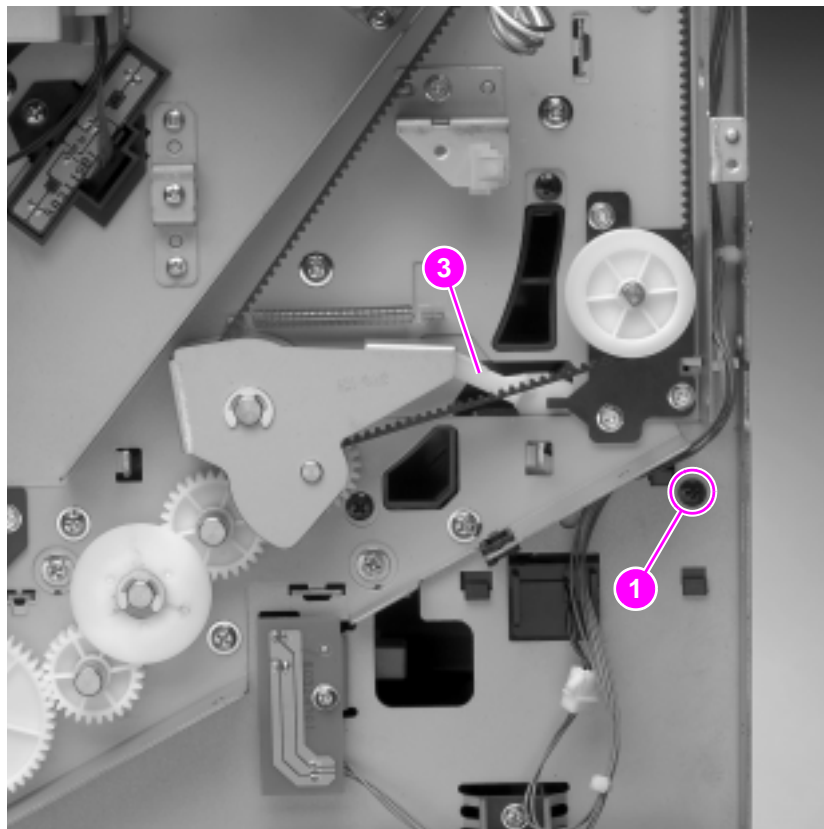
### Notes on reinstalling:

- Verify that the gears on the left mesh together on both the top and the bottom of the assembly.
- Replace the screw inside the front door for the right side of the bar.

## Face-up solenoid

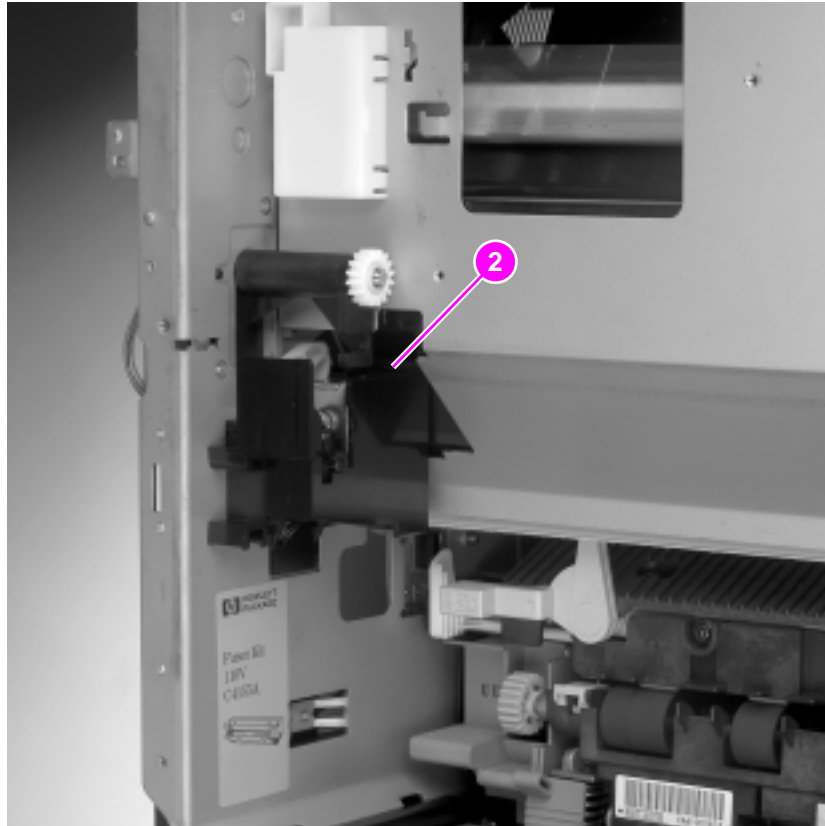
The face-up solenoid is below the carousel stop.

- 1 Remove the feeder assembly (see page 233).
- 2 Remove the face-up output bin.
- 3 Remove the formatter board and formatter pan (see page 230 and page 248).
- 4 Remove 1 screw inside the back of the printer (callout 1).



**Figure 104.** Face-up solenoid

- 5 Lift the face-up solenoid up to release the tab and pull out to remove the solenoid (callout 2).



**Figure 105.** Face-up solenoid

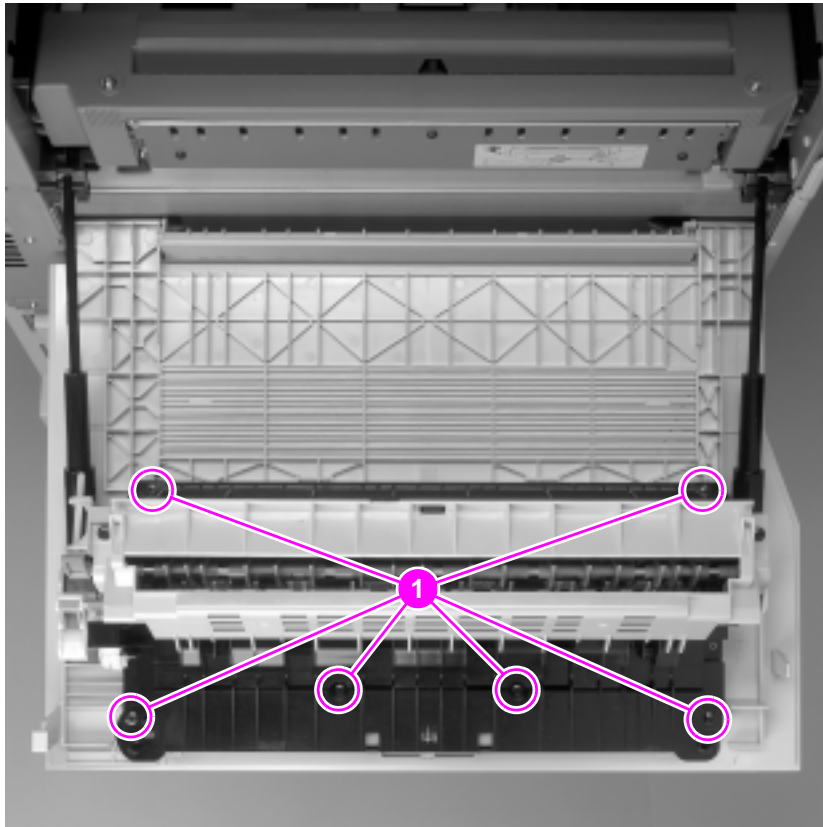
**Notes on reinstalling:**

- Ensure that the plastic arm from the solenoid is engaged under the delivery drive swing arm (callout 3, figure 104).

## Face-up exit assembly

The face-up exit assembly is located on the left lower cover.

- 1 Remove the left lower cover (see page 216).
- 2 Remove 6 screws (callout 1).



**Figure 106.** Screws on the face-up exit assembly

- 3 Remove the stopper hinges by popping the peg out of the door assembly.
- 4 Lift the assembly out.

### Notes on reinstalling:

- The larger peg on the stopper hinge fits into the assembly.

## Right assemblies

The following assemblies can be accessed from the right side of the printer:

- tray 1
- pick-up roller
- registration roller assembly
- paper photo sensors
- density sensor
- paper pick-up assembly
- tray 1 pick-up assembly

### Tray 1

Tray 1 is part of the right upper door. Take the tray off and save it if you are replacing the whole assembly. The new assembly does not include the tray.

- 1 Open the tray about 45-degrees out.



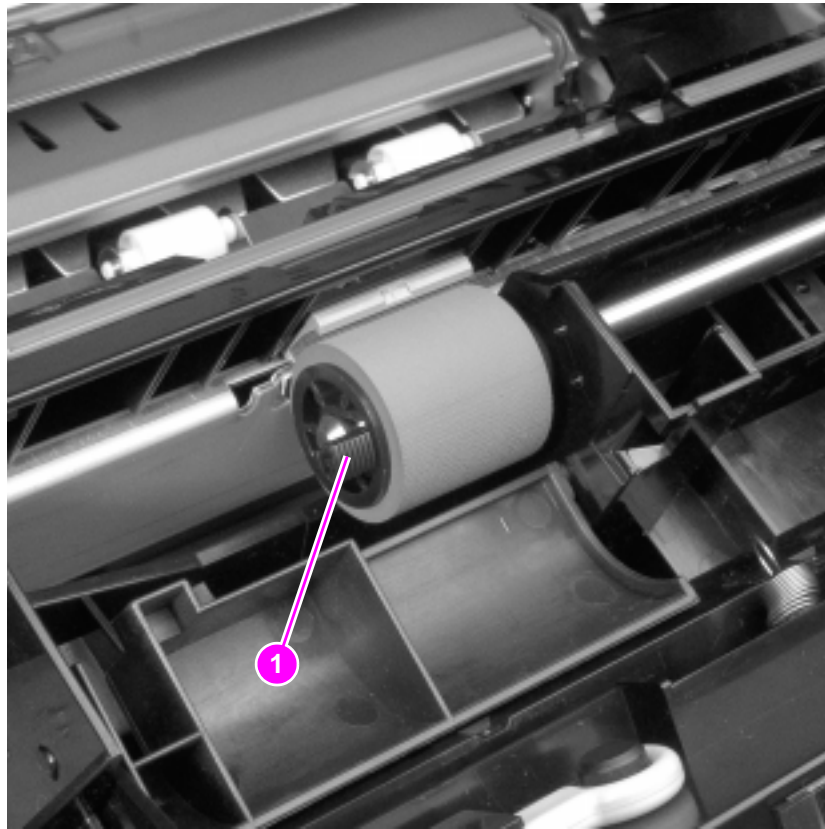
**Figure 107.** Tray 1

- 2 Open the extender all the way out.
- 3 Grasp both sides and bend towards the middle. Pull the left side of the tray out first, then pull the right side of the tray out.
- 4 Unplug 1 connector on the right side (callout 1).

## Pick-up roller

The pick-up roller is located on the tray 1 pick-up assembly.

- 1 Open the right upper door.
- 2 Rotate the roller cover back off of the roller.
- 3 Squeeze the tabs on the roller and pull to the left to remove the roller (callout 1).



**Figure 108.** Pick-up roller

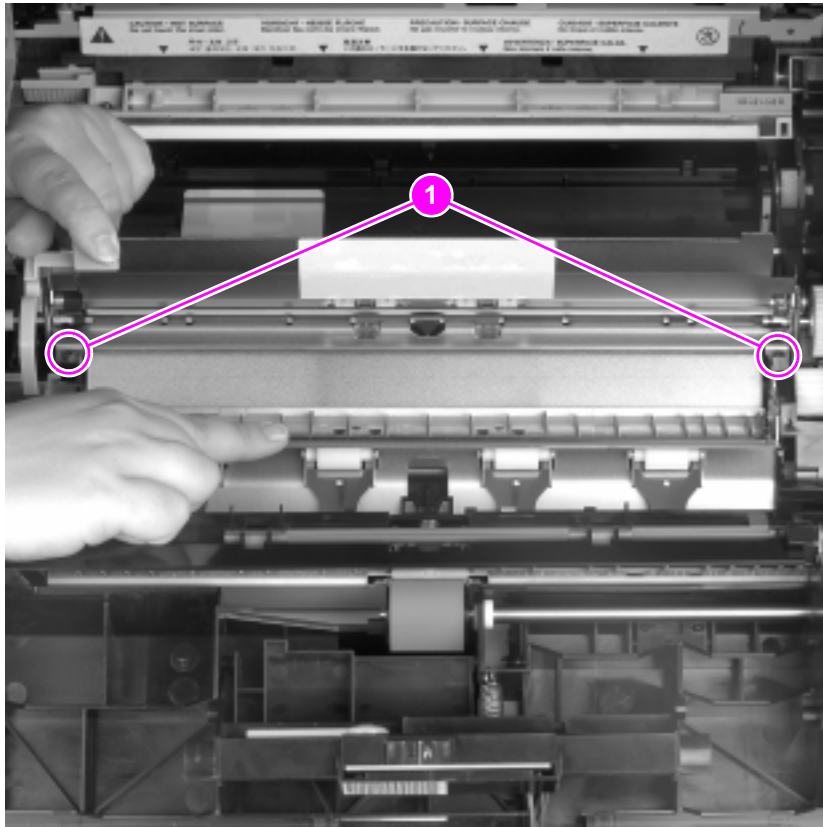


## Registration roller assembly

The registration roller assembly is located inside the right upper door under the transfer belt.



- 1 Open the front door and the right upper door.
- 2 Remove the transfer drum.
- 3 Remove the transfer belt.
- 4 Lift the paper diverter and remove 2 screws (callout 1).

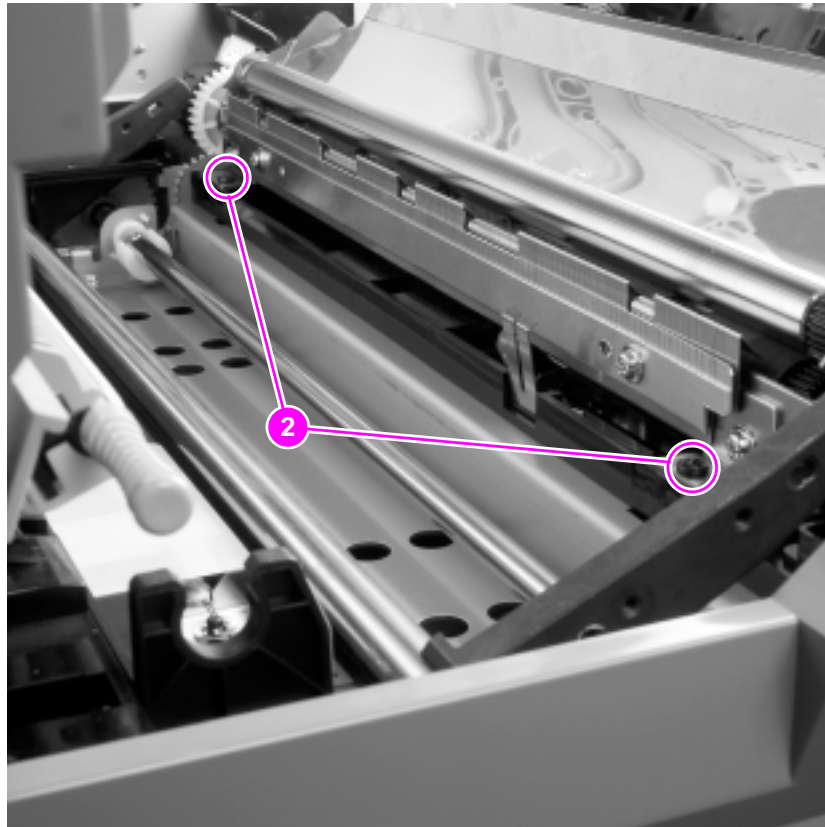


**Figure 109.** Registration roller assembly (front)

5 Remove 2 screws on the back of the assembly (callout 2).

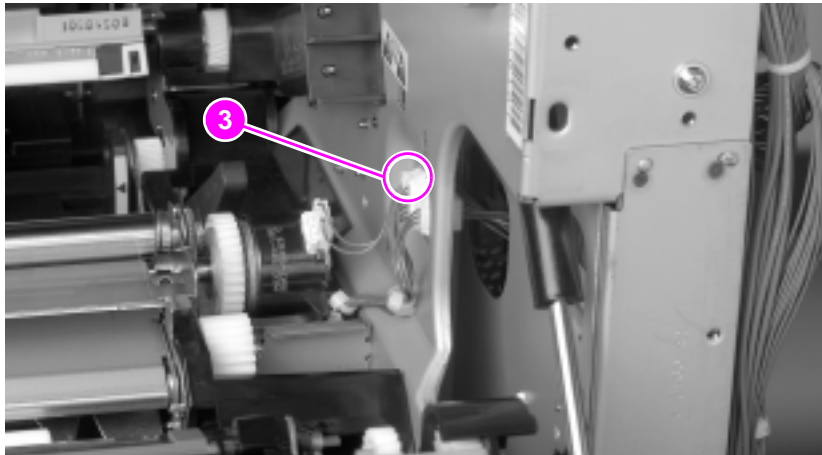
**Hint**

You might need to use a shorter screwdriver to get the back screws out.



**Figure 110.** Registration roller assembly (back)

- 6 Release and remove the cover over the connectors on the right side of the registration roller assembly.
- 7 Unplug the innermost connector on the right side (callout 3).



**Figure 111.** Connectors on registration roller assembly

- 8 Remove 1 screw from the green knob on the front of the printer and remove the knob.
- 9 Pull the registration roller assembly out.

**Notes on reinstalling:**

- When you replace the registration roller assembly, make sure the gears mesh or you could cause scarring.

## Paper photo (OHT) sensors

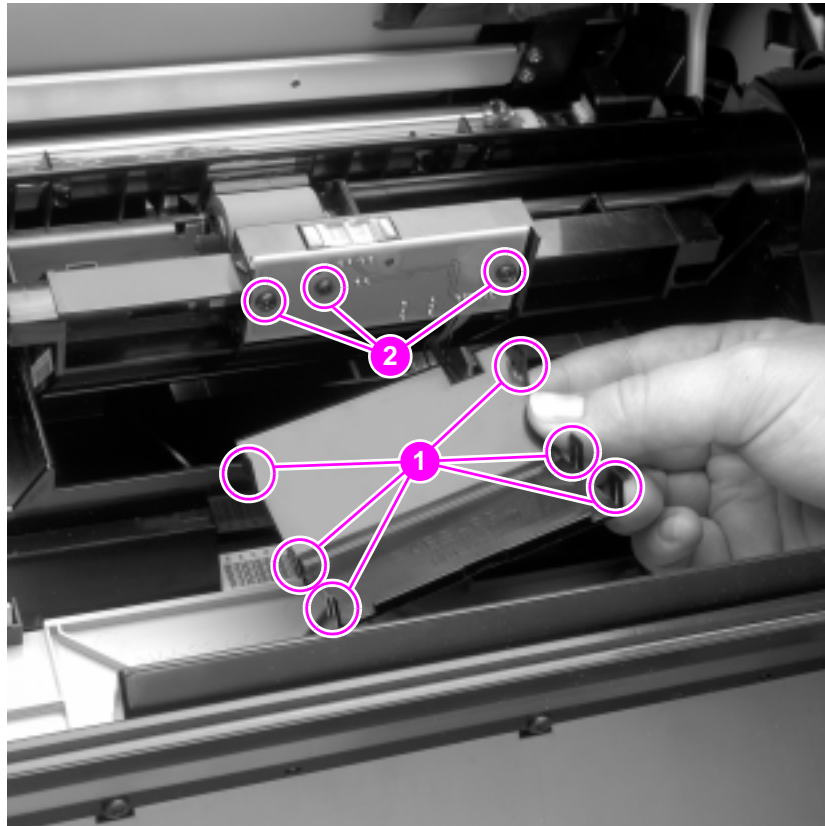
The paper photo sensors are located under the registration frame assembly and are used to sense overhead transparencies.

- 1 Remove the registration roller assembly (see page 239).
- 2 Remove the 2 paper photo sensors by releasing the 2 clasps on each sensor and unplugging one connector on each sensor.

## Density sensor

The density sensor is located on the right upper door.

- 1 Open the right upper door.
- 2 With a flat screwdriver release the 6 tabs on the sensor cover (callout 1).



**Figure 112.** Density sensor

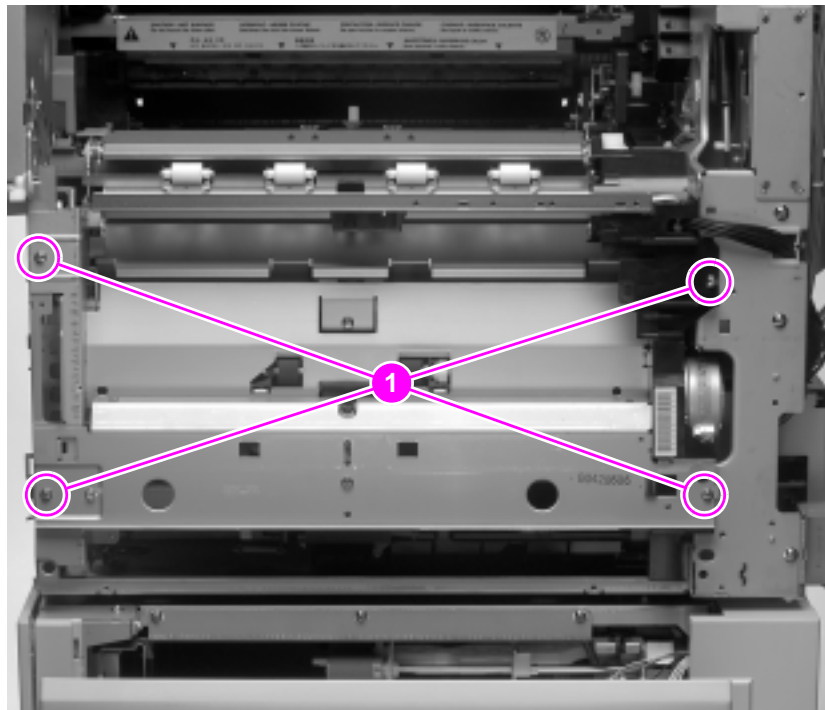
- 3 Remove 3 screws from the sensor (callout 2).
- 4 Unplug 1 connector and remove the sensor.

## Paper pick-up assembly

The paper pick-up assembly is located inside the right upper cover assembly.



- 1 Remove trays 2 and 3.
- 2 Remove the right upper cover assembly (see page 217).
- 3 Remove the right lower cover assembly (see page 221).
- 4 Remove 4 screws, one in each corner of the paper pick-up assembly (callout 1) and pull the assembly out approximately 5 cm (2 in).



**Figure 113.** Paper pick-up assembly

- 5 Unplug 1 connector on the right that goes to the paper pick-up PCA on the right side of the paper pick-up assembly.
- 6 Lift out the paper pick-up assembly.

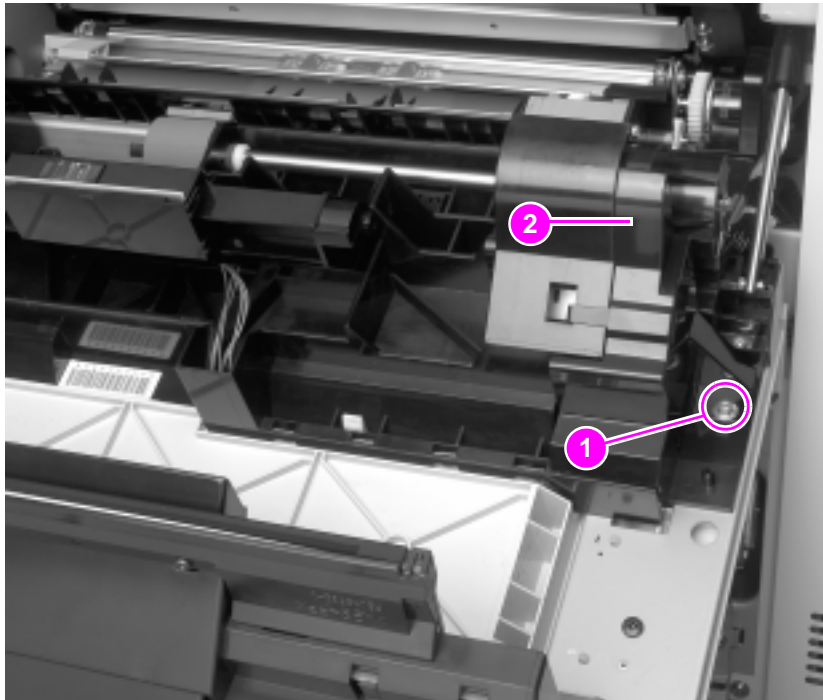
### Notes on reinstalling:

- Plug in the connector and reroute the wires before replacing the assembly.

## Tray 1 pick-up assembly

The tray 1 pick-up assembly is located on the right upper door.

- 1 Open the right upper door.
- 2 Remove the screw on the right side of the assembly (callout 1).



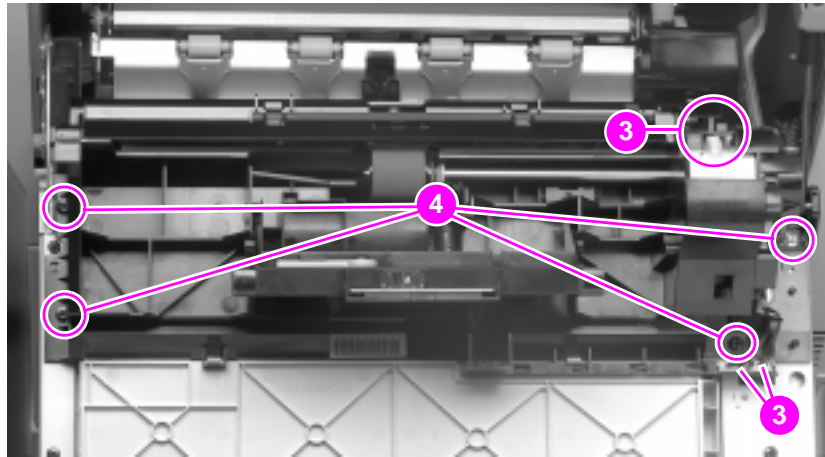
**Figure 114.** Paper pick-up assembly

- 3 Remove the cover on the right side of the assembly (callout 2).

- 4 Unplug the 4 connectors on the right side (callout 3).

**Note**

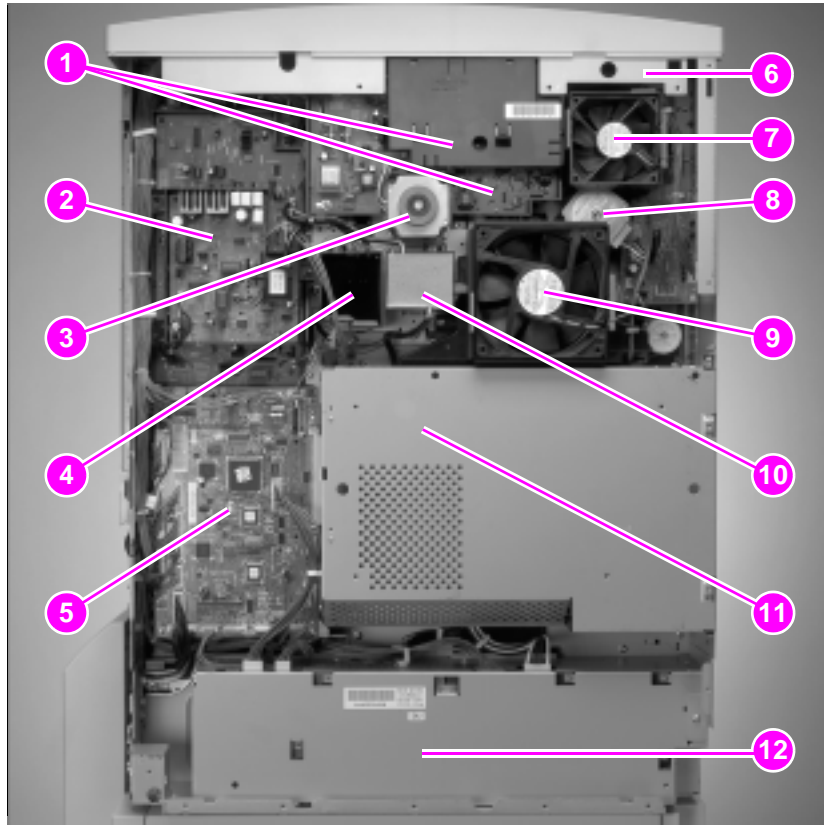
Two connectors are plugged into the controller board, and two connectors are inline connectors. It might be easier to disconnect the connectors from the rear of the printer and pull the wires through the printer frame than to unplug the connectors from the right upper door.



**Figure 115. Paper pick-up assembly**

- 5 Remove 4 screws (callout 4).
- 6 Release 2 clips and lift the assembly off.

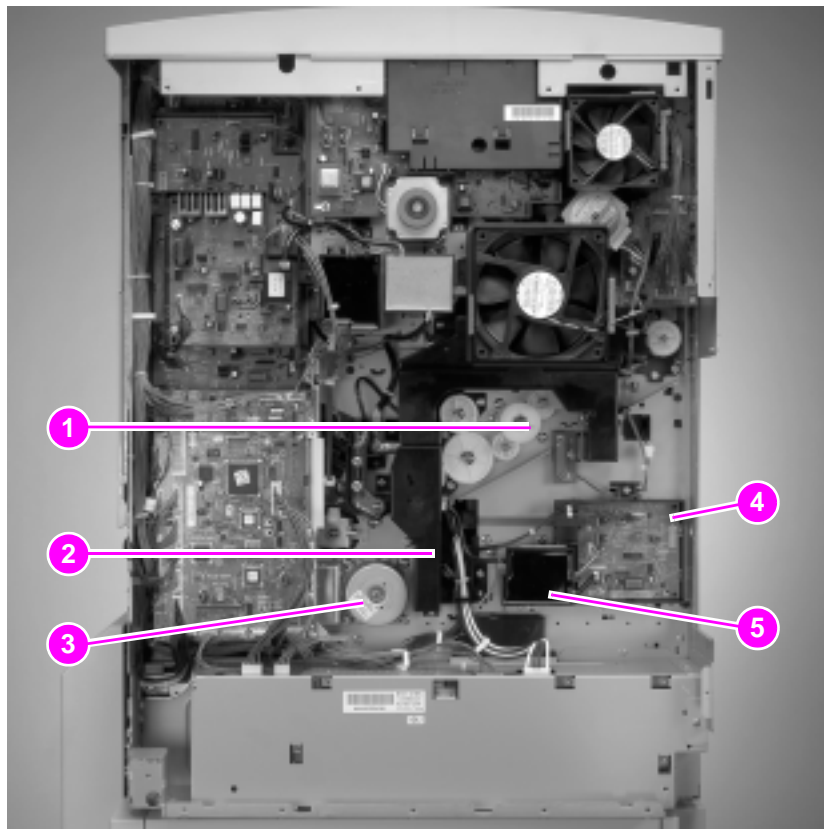
## Rear assemblies



**Figure 116.** Rear of printer with cover removed

- |   |   |    |                          |
|---|---|----|--------------------------|
| 1 | High-voltage converter 1 PCA  | 7  | Fan 2                    |
| 2 | High-voltage converter 2 PCA<br>(the main relay PCA is located<br>behind this assembly) | 8  | Carousel motor (M1)      |
| 3 | Cartridge motor (M3)  | 9  | Fan 1                    |
| 4 | High-voltage converter 1  | 10 | High-voltage converter 2 |
| 5 | Controller board  | 11 | Formatter pan            |
| 6 | Sheet metal cover plate   | 12 | Power supply             |





**Figure 117.** Rear of printer with formatter pan removed

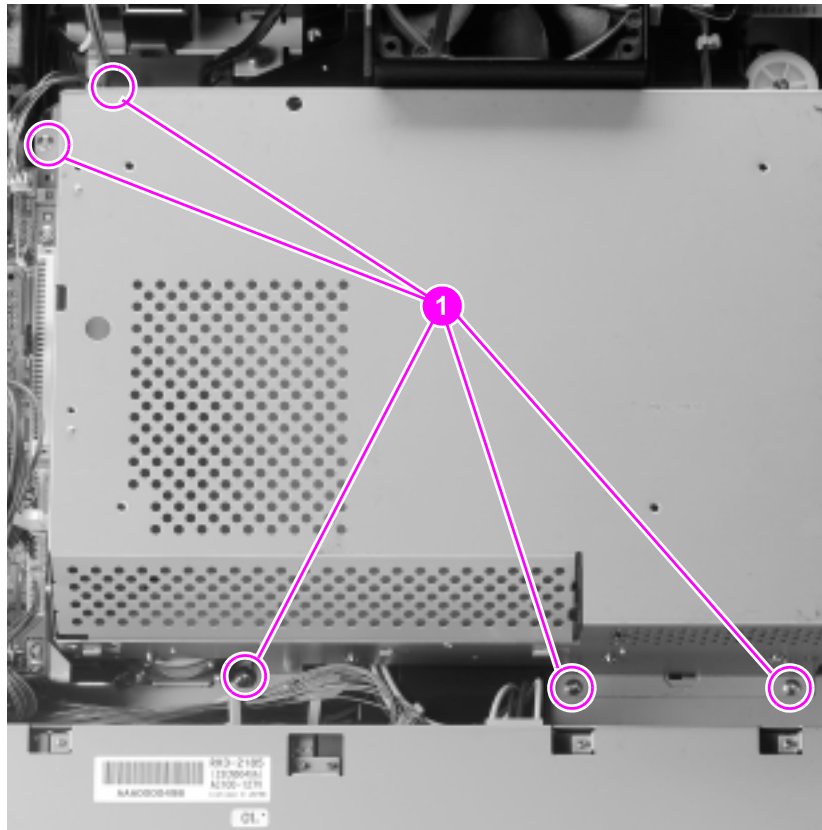
- |   |                         |   |   |
|---|-------------------------|---|---|
| 1 | Delivery drive assembly | 4 | Separation discharge high-voltage converter PCA |
| 2 | Lower air duct          | 5 | Separation discharge high-voltage converter     |
| 3 | Main motor (M4)         |   |   |

- The main relay PCA is behind the high-voltage converter 2 PCA.
- The main gear assembly is behind the high-voltage converter 1 PCA.
- The tray 2 and tray 3 media size sensing PCAs are located behind the power supply.



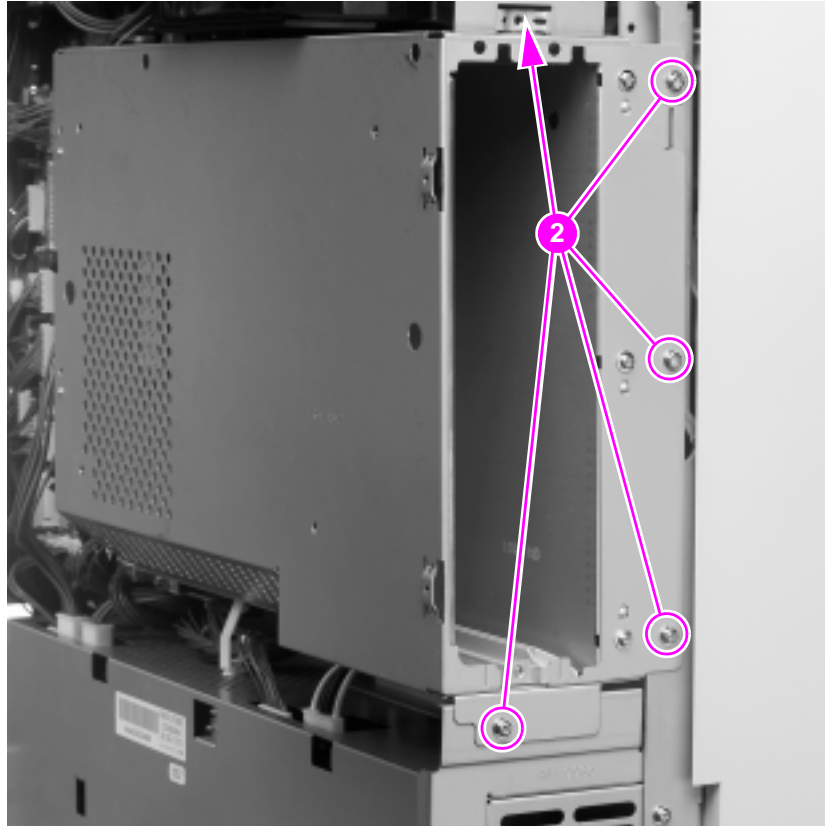
## Formatter pan

- 1 Remove the rear cover (see page 222).
- 2 Remove the formatter board from the formatter pan (see page 230).
- 3 On the back of the printer, remove 2 screws on the top and 3 on the bottom of the pan (callout 1).



**Figure 118.** Formatter pan

- 4 Remove 5 screws on the left side of the printer (callout 2).



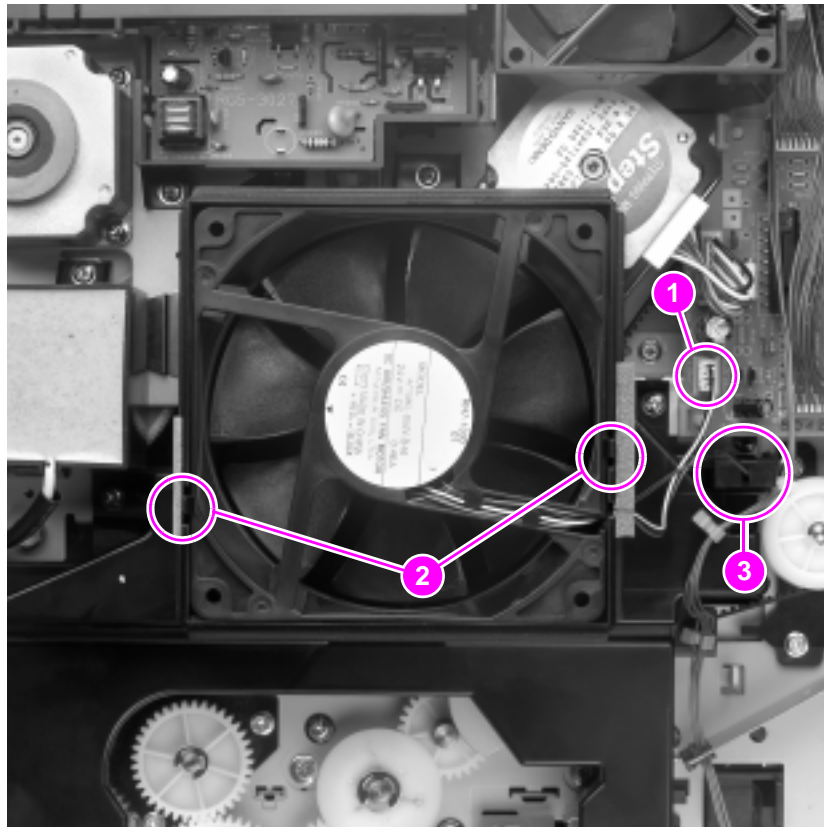
**Figure 119.** Formatter pan (left side)

- 5 Pull the formatter pan off.

## Fan 1

Fan 1 is located on the middle right side of the rear of the printer. For information on removing the fan 1 housing, see page 257 (steps 4 through 6).

- 1 Remove the rear cover (see page 222).
- 2 Unplug the fan connector from the PCA (callout 1).



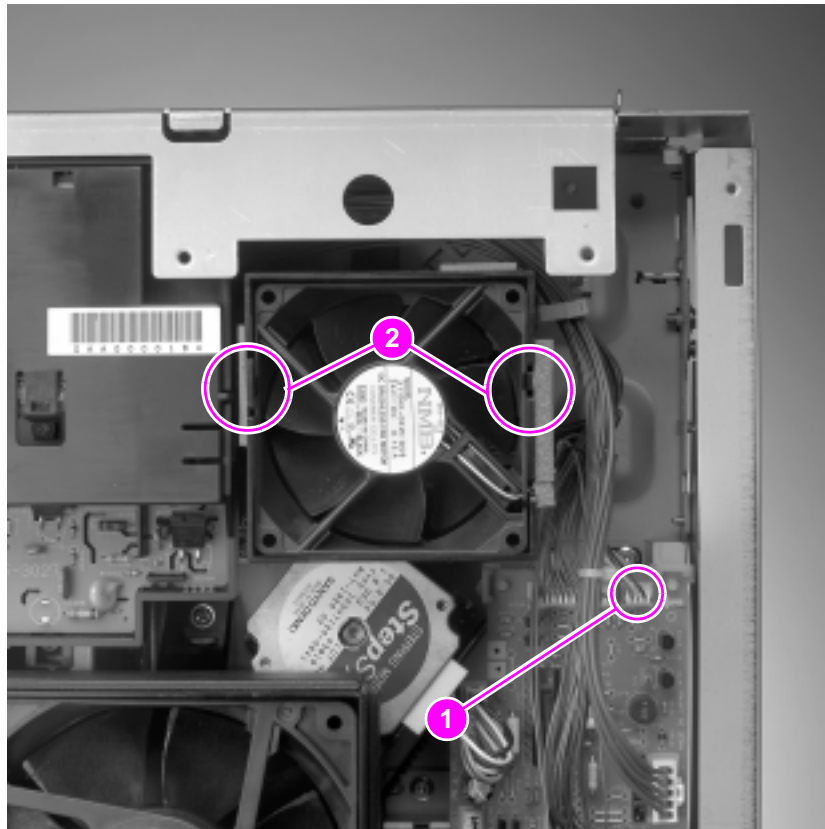
**Figure 120.** Fan 1

- 3 Push out on the two tabs on the left and right sides of the fan housing (callout 2).
- 4 Pull the thermistor out (callout 3).
- 5 Pull the fan out.

## Fan 2

Fan 2 is located on the upper right side of the rear of the printer. For information on removing the fan 2 housing, see page 257 (steps 7 through 8).

- 1 Remove the rear cover (see page 222).
- 2 Unplug 1 connector (callout 1).



**Figure 121.** Fan 2

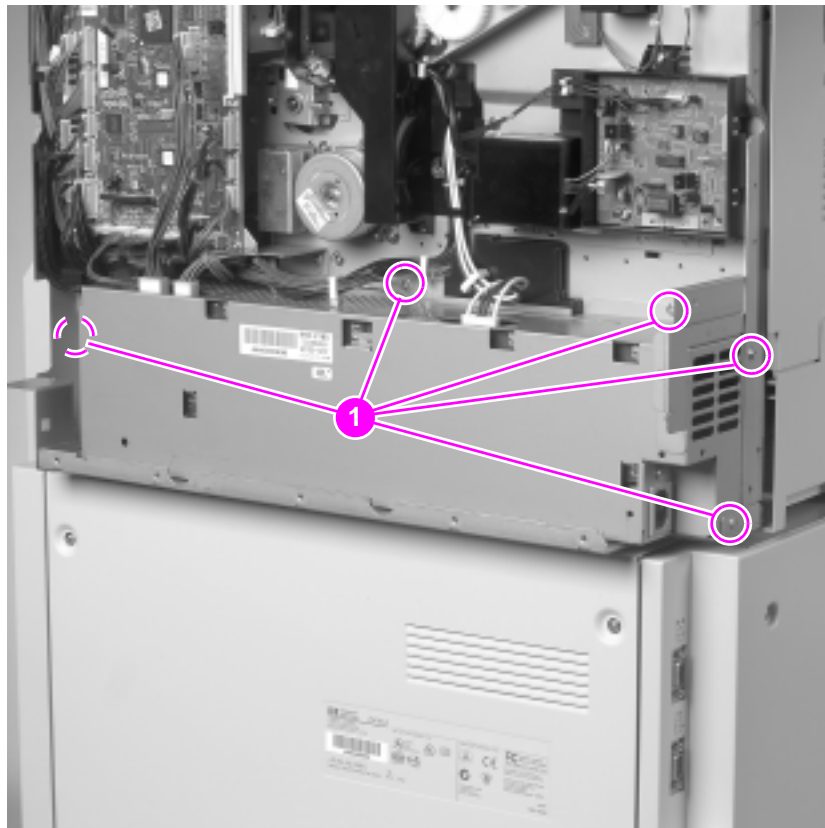
- 3 Push out on the tabs on the left and right sides of the fan housing to release the fan (callout 2).
- 4 Pull the fan out.

## Power supply

The power supply is located on the lower right side of the rear of the printer.



- 1 Remove the rear cover (see page 222).
- 2 Remove the formatter board and formatter pan (see page 230 and page 248).
- 3 Unplug the 5 connectors.
- 4 Release 1 cable stay.
- 5 Remove 5 screws (2 in the top, 1 on the left, 2 on the right) (callout 1).



**Figure 122.** Power supply

- 6 Lift the power supply out of the chassis.

## Controller board

The controller board is located on the lower left side of the rear of the printer.

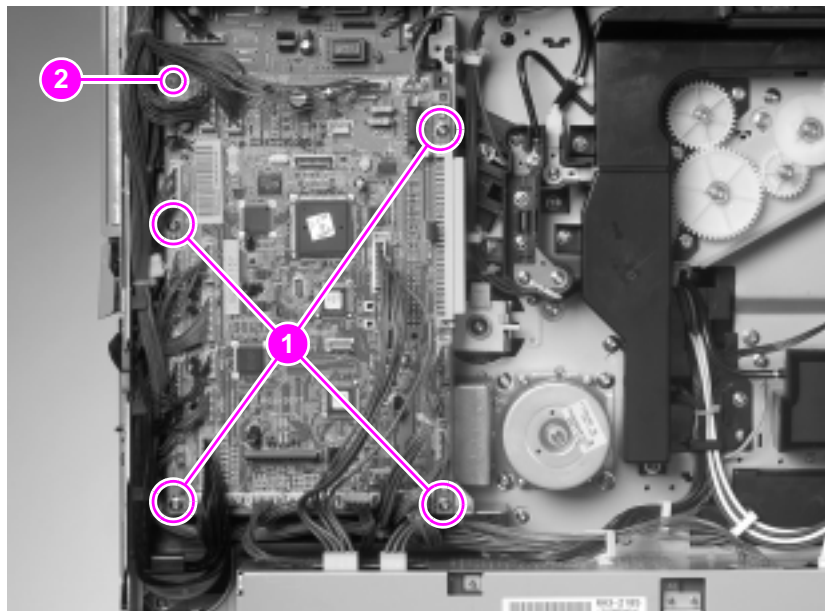


- 1 Print a configuration page if the printer is able to generate one (see page 361). This page can be used to reset the page count values that will be lost if the controller board is replaced.
- 2 Remove the rear cover (see page 222).
- 3 Remove the formatter board and formatter pan (see page 230 and page 248).
- 4 Unplug 25 connectors.

### Hint

All 25 connectors are keyed. Also, it is easier to unplug the connectors before removing the screws from the PCA.

- 5 Remove 4 screws (callout 1).



**Figure 123.** Controller board

- 6 Push the white plastic holding tab in the upper left corner to the left (callout 2), and pull the controller board straight out.

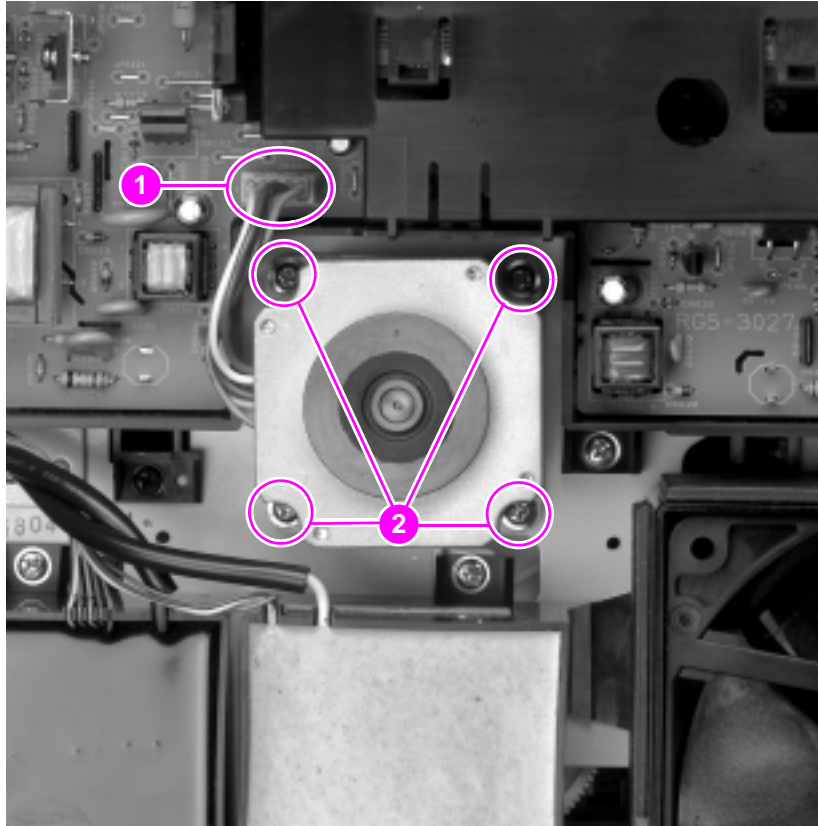
### Notes on reinstalling:

- When putting the controller board back in, the pins on the back connector must be lined up or you might damage the pins.

## Cartridge motor (M3)

This motor is located to the left of fan 1.

- 1 Remove the rear cover (see page 222).
- 2 Unplug 1 connector (callout 1).



**Figure 124.** Cartridge motor

- 3 Remove 4 screws on the motor (callout 2), and pull the motor out.

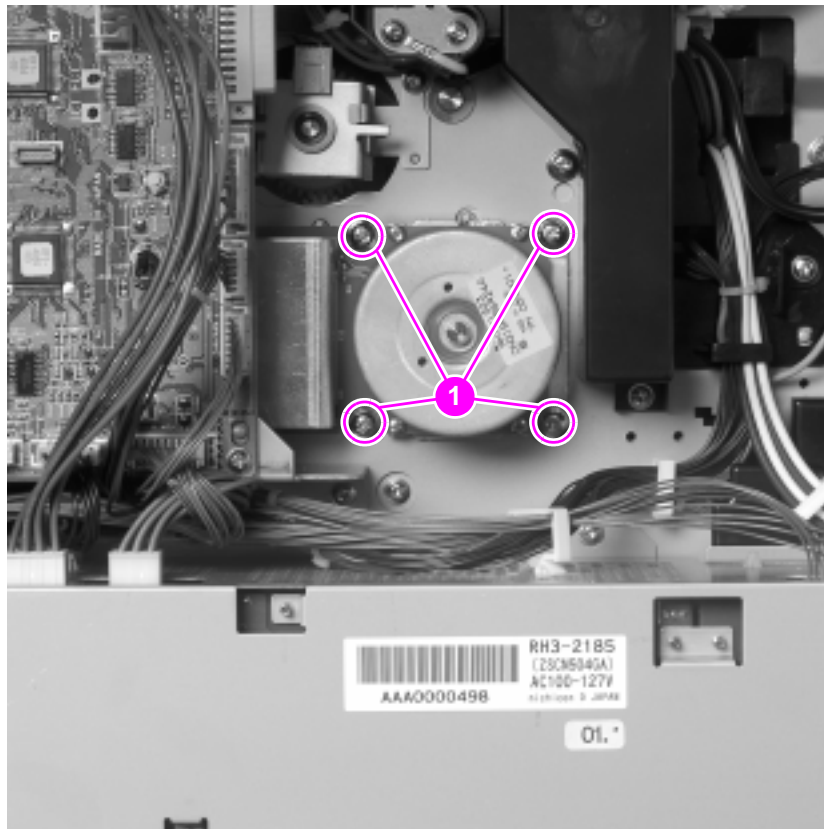


## Main motor (M4)

This motor is located to the right of the controller board, behind the formatter pan.



- 1 Remove the rear cover (see page 222).
- 2 Remove the formatter board and formatter pan (see page 230 and page 248).
- 3 Unplug 1 connector.
- 4 Remove 4 screws (callout 1), and pull the motor away from the chassis.



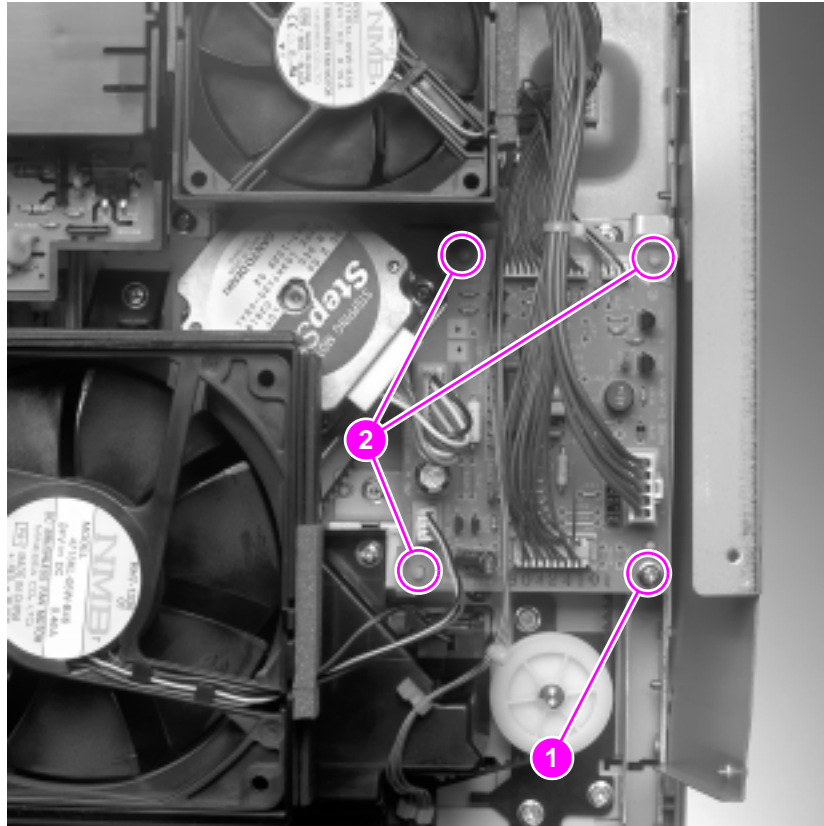
**Figure 125.** Main motor

## Carousel motor PCA

This PCA is located on the upper right side of the rear of the printer.



- 1 Remove the rear cover (see page 222).
- 2 Unplug 6 connectors.
- 3 Remove 1 screw (callout 1).



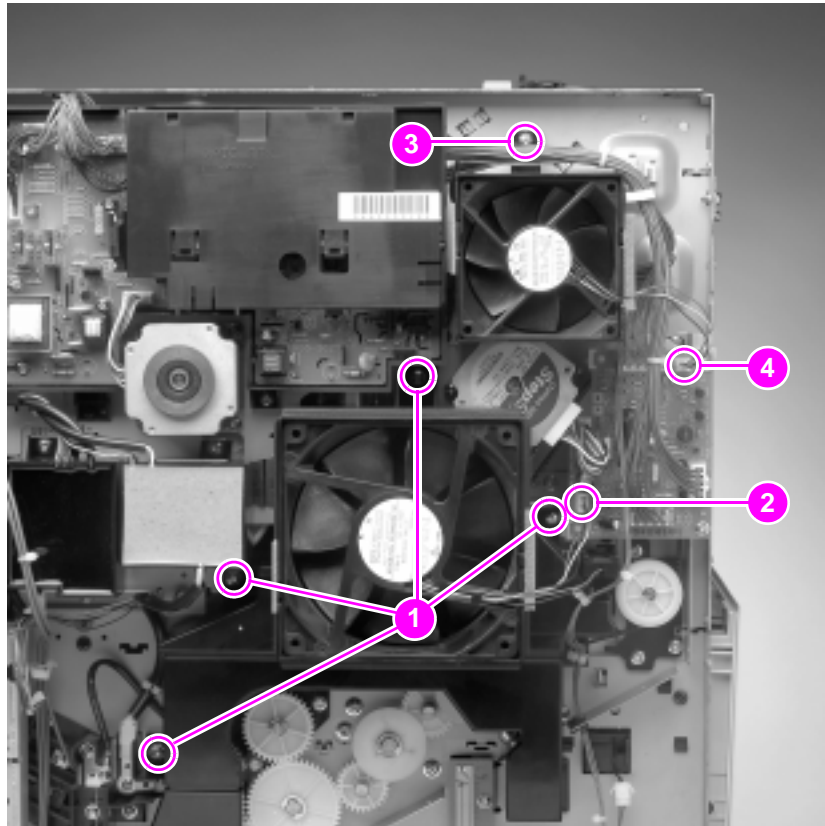
**Figure 126.** Carousel motor PCA

- 4 Release 3 tabs from the PCA (callout 2).
- 5 Lift the PCA out.

## Carousel motor (M1)

The carousel motor is located behind the fan 1 housing.

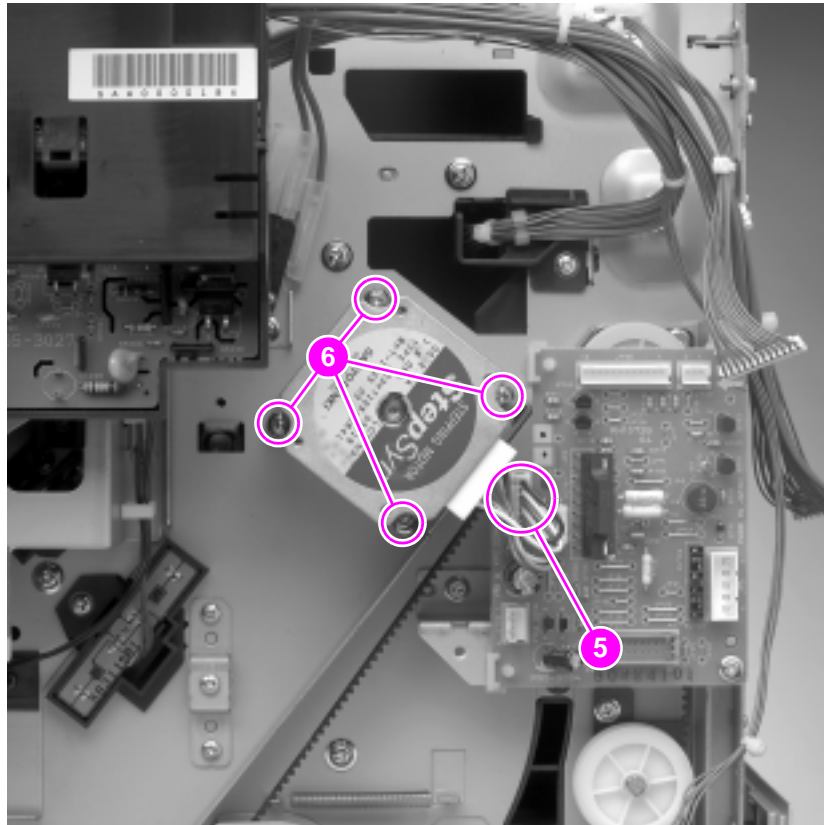
- 1 Remove the top cover assembly (see page 211).
- 2 Remove the rear cover (see page 222).
- 3 Remove the formatter board and formatter pan (see page 230 and page 248).
- 4 Remove the 5 screws from the sheet metal cover plate and lift it off.
- 5 Remove 4 screws from the fan 1 assembly (callout 1).



**Figure 127.** Fans 1 and 2 housing assemblies

- 6 Release 2 cable stays and unplug 1 connector on the right side of the assembly (callout 2) to remove the housing.
- 7 Remove 1 screw from the fan 2 assembly (callout 3).

- 8 Release 1 cable stay and unplug 1 connector from the fan 2 assembly (callout 4) to remove the housing.
- 9 On the right side of the carousel motor, unplug 1 connector (callout 5).



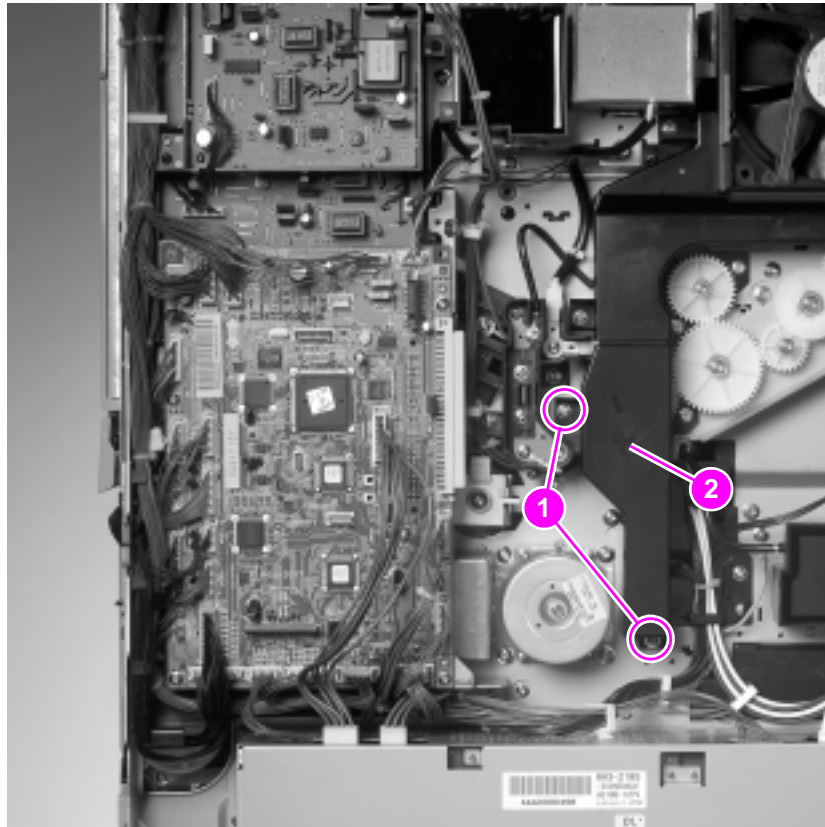
**Figure 128.** Carousel motor

- 10 Remove 4 screws from the motor and lift it out (callout 6).

## Delivery drive assembly

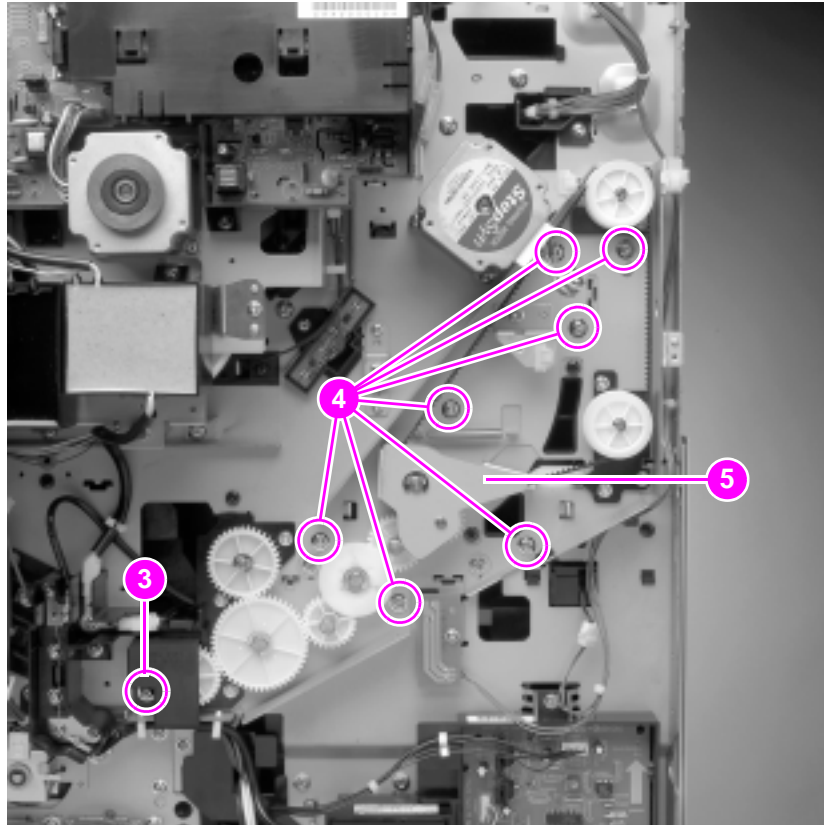
The delivery drive assembly is located behind the fan 1 housing and the formatter pan.

- 1 Remove the carousel motor PCA (see page 256).
- 2 Remove fan 1 housing (see page 257, steps 4 through 6).
- 3 Remove 2 screws (callout 1) from the lower air duct and remove the lower air duct (callout 2).



**Figure 129.** Lower air duct

- 4 Release 3 cable stays on the bottom of the delivery drive assembly.
- 5 Remove 1 screw (callout 3) and the gear cover.



**Figure 130.** Screws on the delivery drive assembly

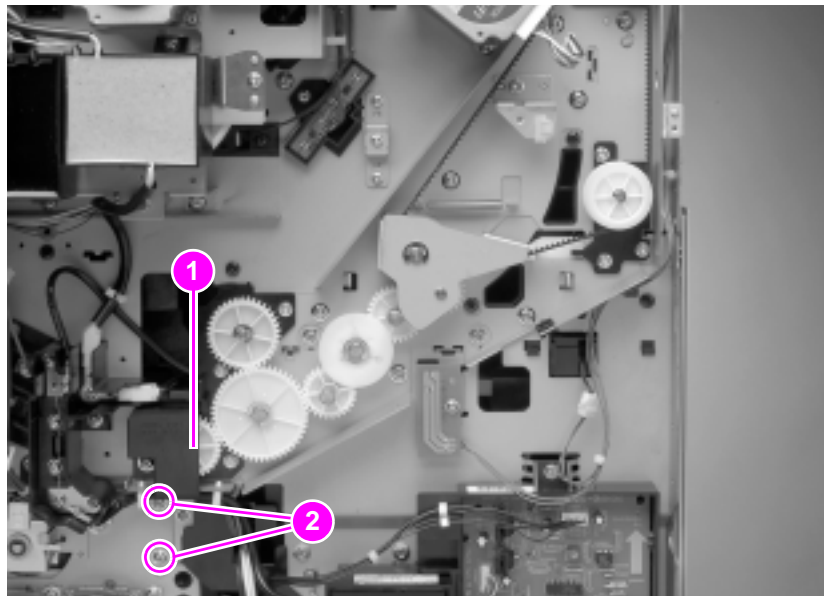
- 6 Remove 7 screws from the delivery drive assembly (callout 4).
- 7 Lift the assembly up and off the tabs.

**Notes on reinstalling:**

- Ensure that the metal swing arm is above the face-up solenoid (callout 5).

## Main gear assembly (not shown)

- 1 Open the left lower cover and remove the fuser.
- 2 Open the right upper door and remove the transfer drum.
- 3 Remove the registration roller assembly (see page 239).
- 4 Remove the paper pick-up assembly (see page 243).
- 5 Remove the main motor (M4) (see page 255).
- 6 Remove the lower air duct (see figure 129 on page 259).
- 7 Remove the lowest gear (callout 1) on the delivery drive assembly (3 screws and 1 e-ring).



**Figure 131.** Access to main gear assembly

- 8 Remove tray 2 and tray 3 from the printer.
- 9 Remove the tray 2 rail from the front of the printer (1 screw, 2 connectors).
- 10 Remove the inner cover 4 (see reference 4, on page 458).
- 11 Remove the lower (green) lever (2 screws).
- 12 Remove the pressure lever (2 e-rings and 2 bushings).
- 13 Remove 2 screws and pull the main gear assembly (callout 2).

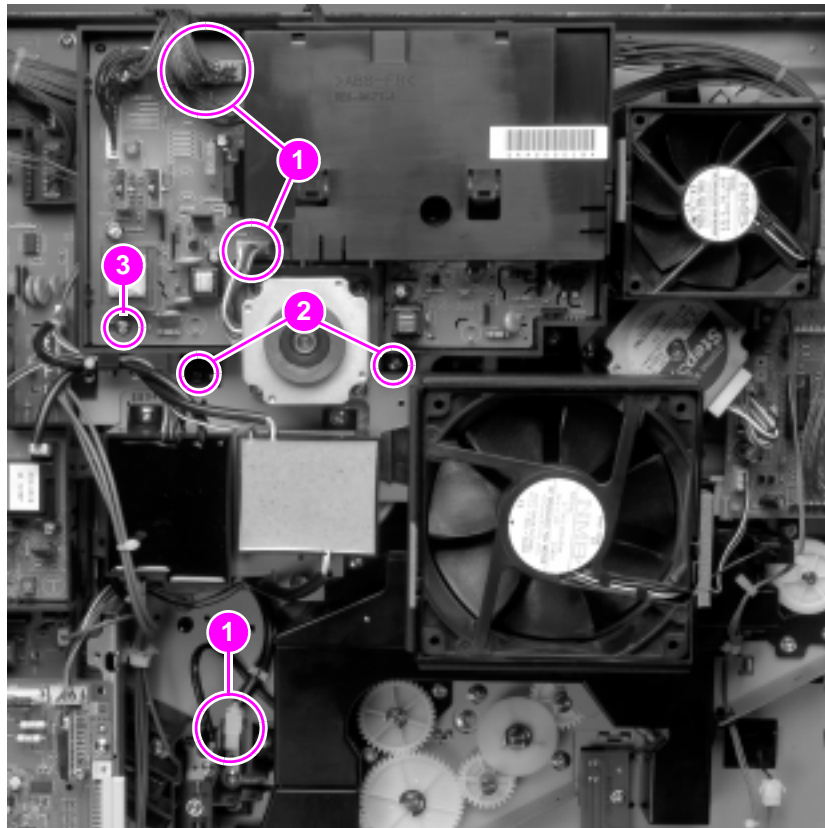
## High-voltage converter 1 assemblies

The high-voltage converter 1 assemblies are located on the mid-upper of the rear of the printer.



### Removing high-voltage converter 1 PCA

- 1 Remove the top cover assembly (see page 211).
- 2 Remove the rear cover (see page 222).
- 3 Remove 5 screws from the sheet metal cover plate and lift it off.
- 4 Unplug 4 connectors (callout 1).



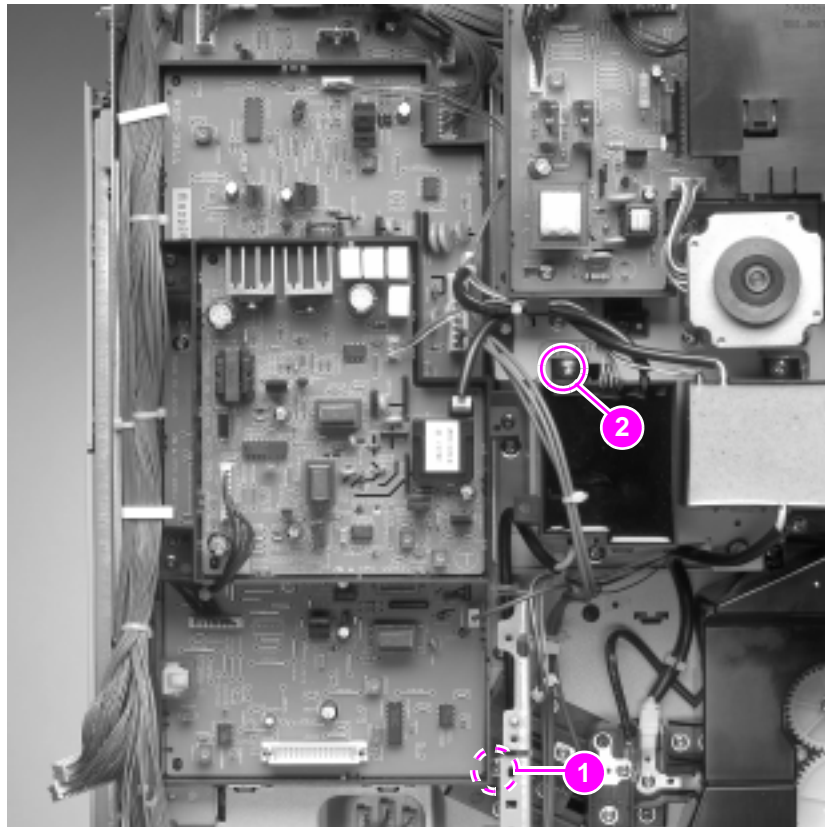
**Figure 132.** High-voltage converter 1 PCA

- 5 Release 2 cable stays.
- 6 Remove 2 screws on the bottom of the PCA housing (callout 2).
- 7 Remove 1 screw on the PCA (callout 3).
- 8 Lift the PCA up and off.



## Removing high-voltage converter 1

- 1 Remove the high-voltage converter 2 PCA (see page 264).
- 2 Remove 1 screw to release the wire from the open ended diode (callout 1, screw is hidden from view).



**Figure 133.** High-voltage converter 1

- 3 Release 2 cable stays.
- 4 Remove one screw on the top of the converter (callout 2).
- 5 Lift the converter up and out.

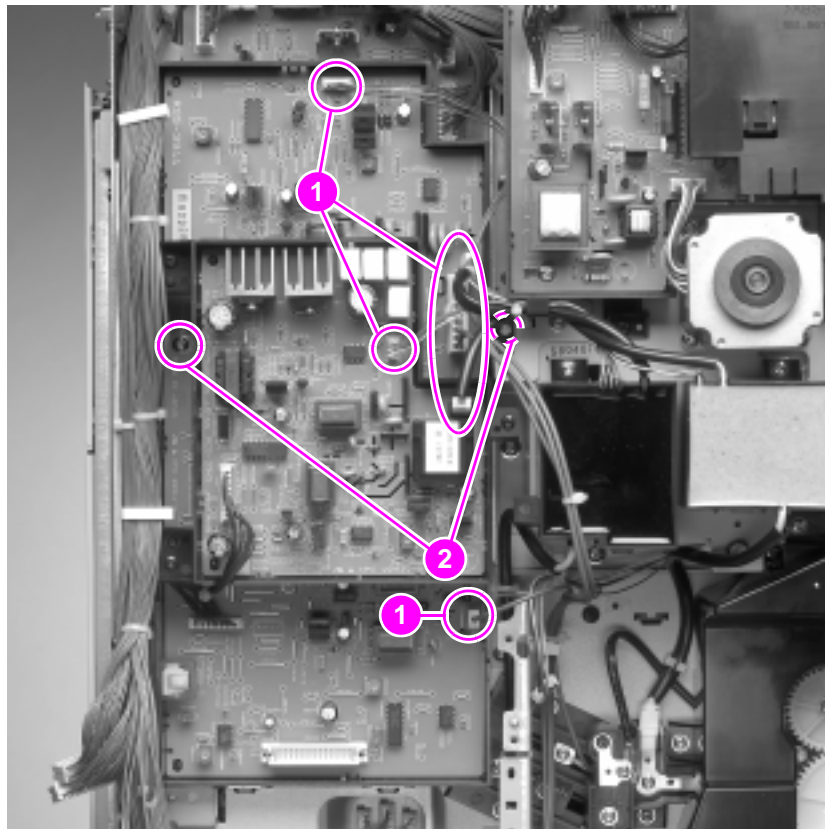


## High-voltage converter 2 assemblies

The high-voltage converter 2 includes two PCAs stacked on top of each other and is located on the upper left side when facing the rear of the printer.

### Removing high-voltage converter 2 PCA

- 1 Remove the rear cover (see page 222).
- 2 Remove the formatter board and formatter pan (see page 230 and page 248).
- 3 Remove the controller board (see page 253).
- 4 Unplug 6 connectors from the PCA (callout 1).



**Figure 134.** High-voltage converter 2 PCA

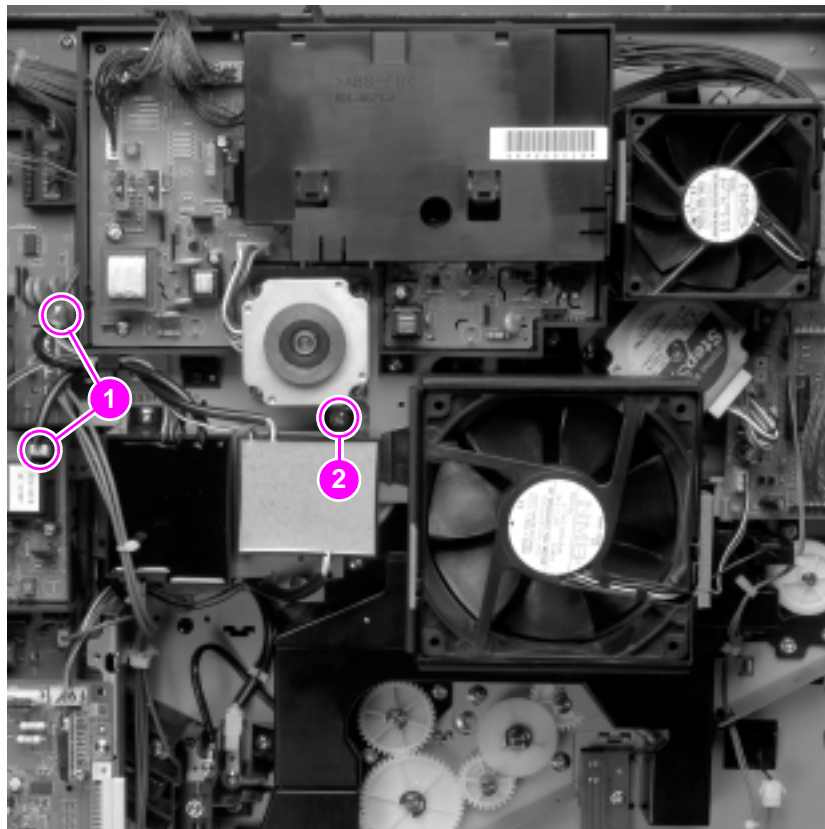
- 5 Release 2 cable stays.
- 6 Remove 2 screws from the PCA (callout 2).
- 7 Lift the PCA up slightly and out.

### Notes on reinstalling:

- Seat the bottom of the PCA first by placing the tabs in the corresponding holes.
- When putting the PCA back in, be sure you do not get any wiring caught behind it.

### Removing high-voltage converter 2

- 1 Remove the rear cover (see page 222).
- 2 Remove the formatter board and formatter pan (see page 230 and page 248).
- 3 Unplug 2 connectors (callout 1).



**Figure 135.** High-voltage converter 2

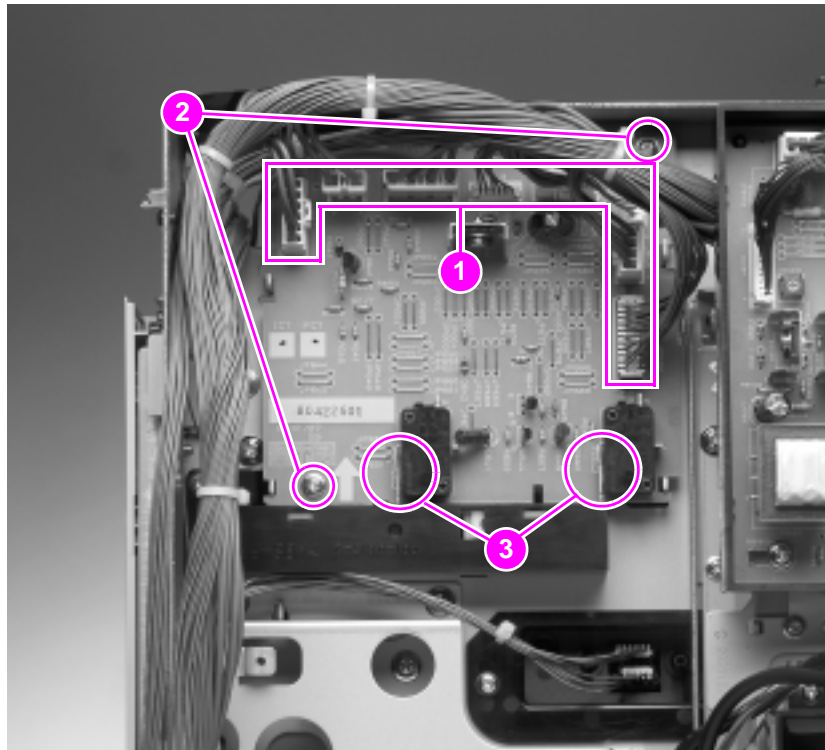
- 4 Release 2 cable stays.
- 5 Remove 1 screw from the top of the converter (callout 2).
- 6 Pull the converter out.



## Main relay PCA

This PCA is located behind the high-voltage converter 1 PCA.

- 1 Remove the rear cover (see page 222).
- 2 Remove 5 screws from the sheet metal cover plate and lift it off.
- 3 Remove the high-voltage converter 1 PCA (see page 264).
- 4 Unplug 8 connectors (callout 1).



**Figure 136.** High-voltage converter 2

- 5 Remove 2 screws (callout 2).

### Note

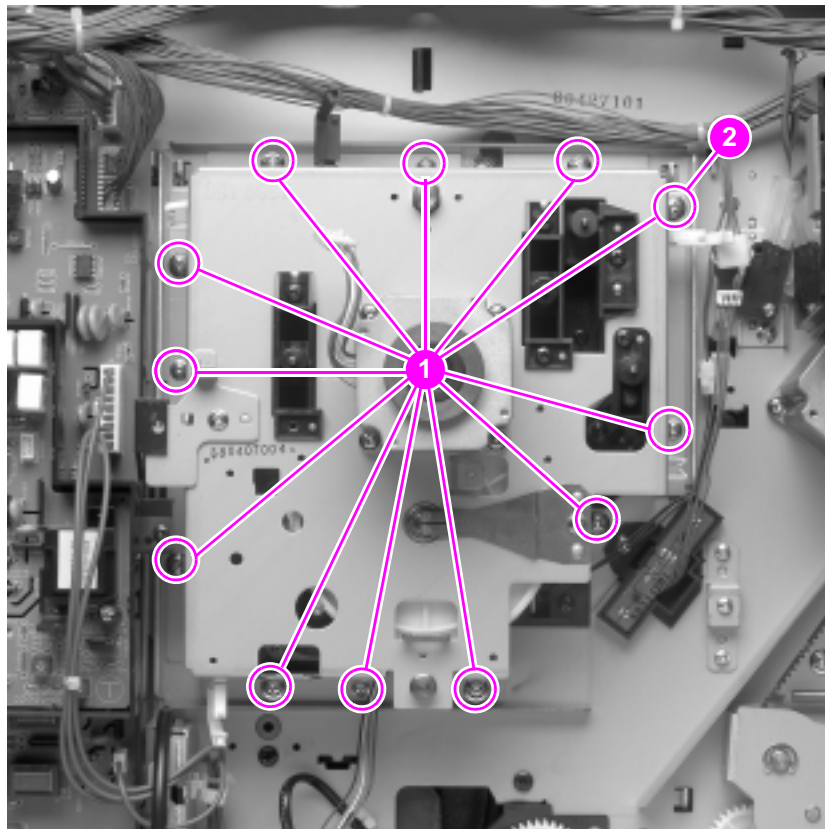
Take note of where the interlock tabs come out of their casing so that you can reinstall them correctly (callout 3).

- 6 Lift the PCA up and out.

## Drum/cartridge drive assembly

This assembly is behind the high-voltage converter 2 PCA assembly.

- 1 Remove the high-voltage converter 1 (see page 263).
- 2 Remove the high-voltage converter 2 and the high-voltage converter 2 PCA (see page 262).
- 3 Remove the fan 1 housing (see page 257, steps 4 through 6).
- 4 Release 3 cable stays.
- 5 Remove 12 screws (callout 1).



**Figure 137.** Drum/cartridge drive assembly

- 6 Lift the assembly up and out.

### Notes on reinstalling:

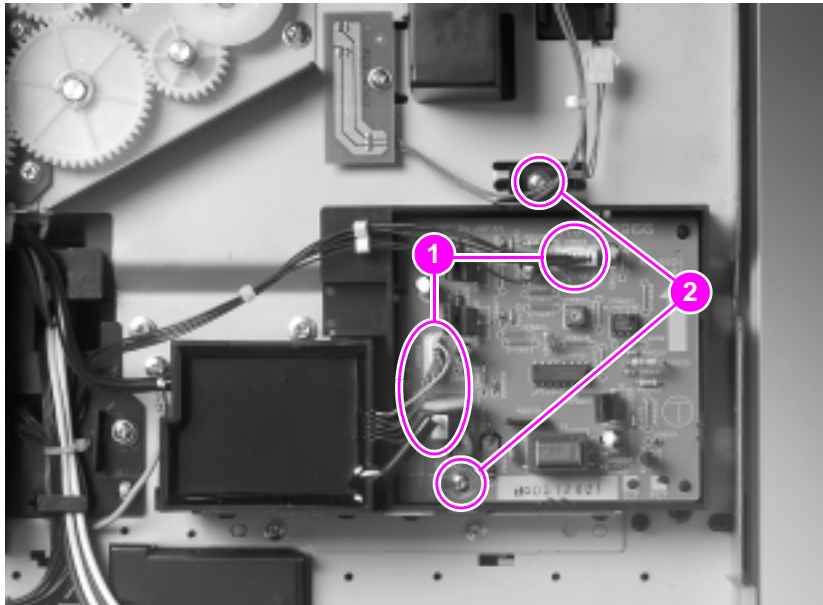
- Replace the screws starting with the callout 2 screw to prevent leading edge banding print defects. Continue to replace screws clockwise around the assembly.

## Separation discharge high-voltage converter assemblies

The separation discharge high-voltage converter assemblies are located in the bottom right corner of the rear of the printer.

### Removing separation discharge high-voltage converter PCA

- 1 Remove the rear cover (see page 222).
- 2 Remove the formatter board and formatter pan (page 230 and page 248).
- 3 Unplug 3 connectors from the PCA (callout 1).



**Figure 138.** Separation discharge high-voltage converter

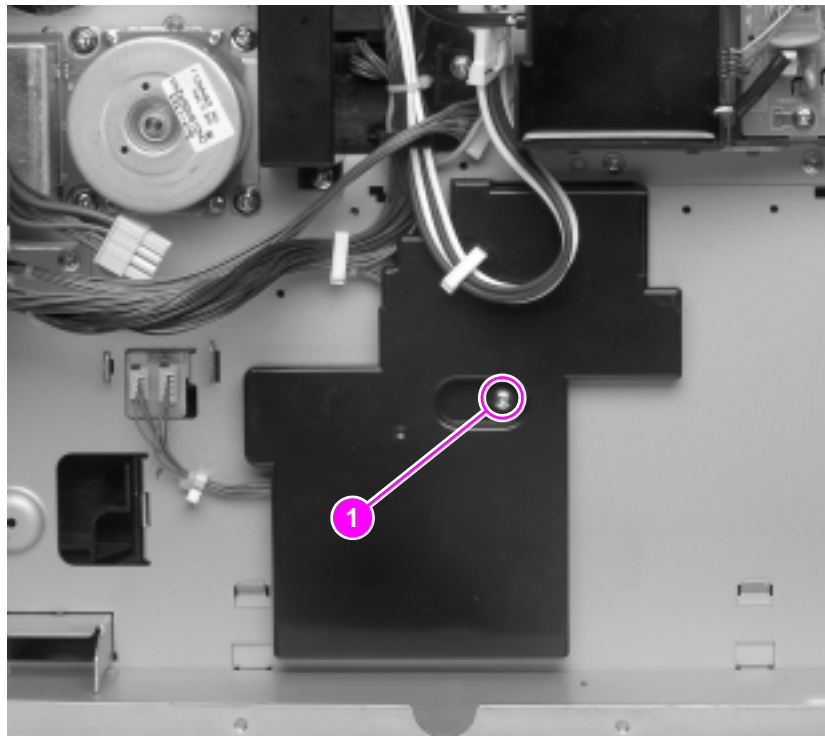
- 4 Release 1 cable stay.
- 5 Remove 2 screws (callout 2).
- 6 Lift the PCA up and off.

## Removing separation discharge high-voltage converter

- 1 Remove the high-voltage converter 3 PCA (see page 268).
- 2 Unplug 1 connector.
- 3 Pull the converter toward you and lift out.

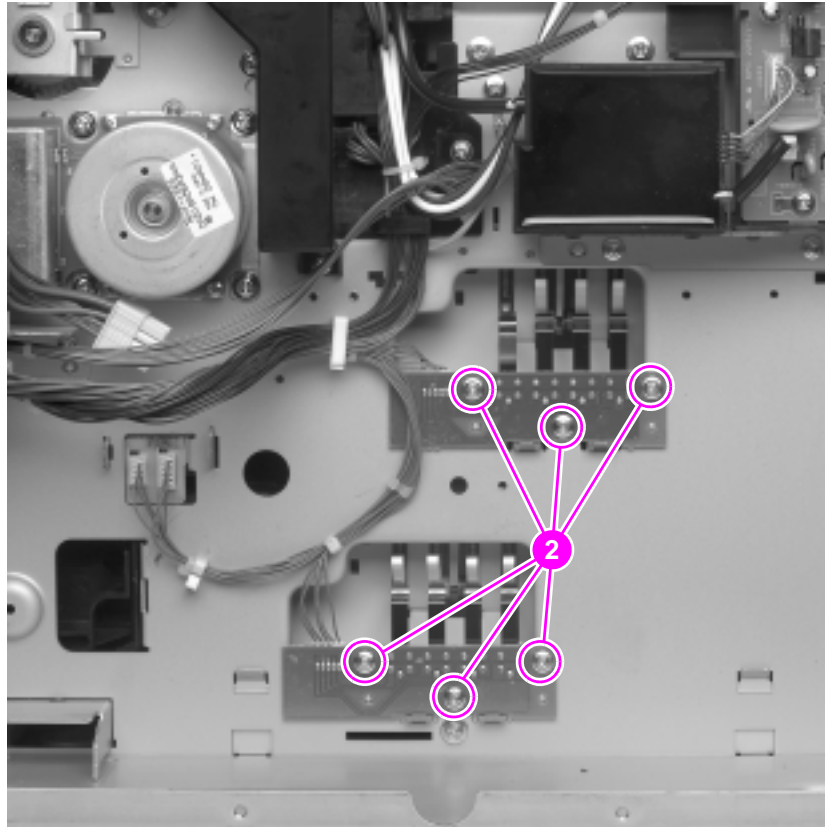
## Tray 2 and tray 3 media size sensing PCAs

- 1 Remove the rear cover (see page 222).
- 2 Remove the formatter board and formatter pan (see page 230 and page 248).
- 3 Remove the power supply (see page 252).
- 4 Release 1 cable stay.
- 5 Remove 1 screw (callout 1) from the plate and remove the plate.



**Figure 139.** Plate over media size sensing PCAs

- 6 Open the corresponding tray.
- 7 Remove 3 screws (callout 2) and unplug 1 connector on each PCA to remove.



**Figure 140.** Media size sensing PCAs

---

**Note** The two PCAs and wire-sensing finger assemblies are interchangeable.

---



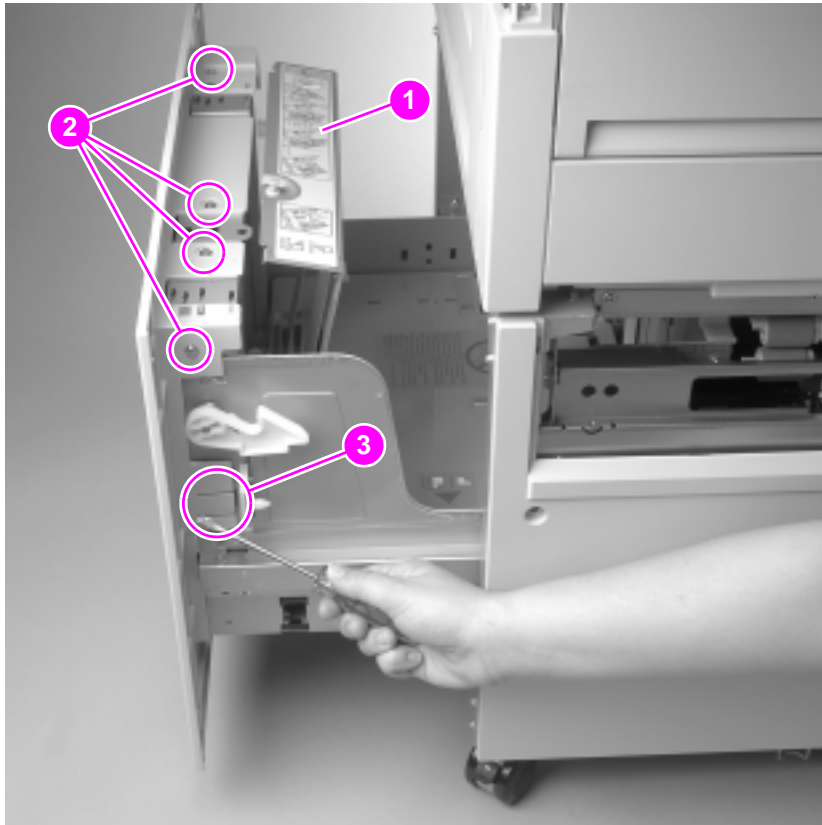
## 2,000-sheet input unit

You do not need to detach the 2,000-sheet input unit from the printer to service any of the units. The replaceable units include:

- front, back, left, and right covers
- vertical transfer unit (VTU)
- tray 4
- paper pick-up assembly
- controller PCA
- front LED PCA assembly
- power supply
- main drive assembly
- paper size sensor assemblies (2)
- tension springs

## Front cover

- 1 Open tray 4 to the stops.
- 2 Remove the paper limit-back plate from the tray (callout 1).



**Figure 141.** Front cover of the 2,000-sheet input unit

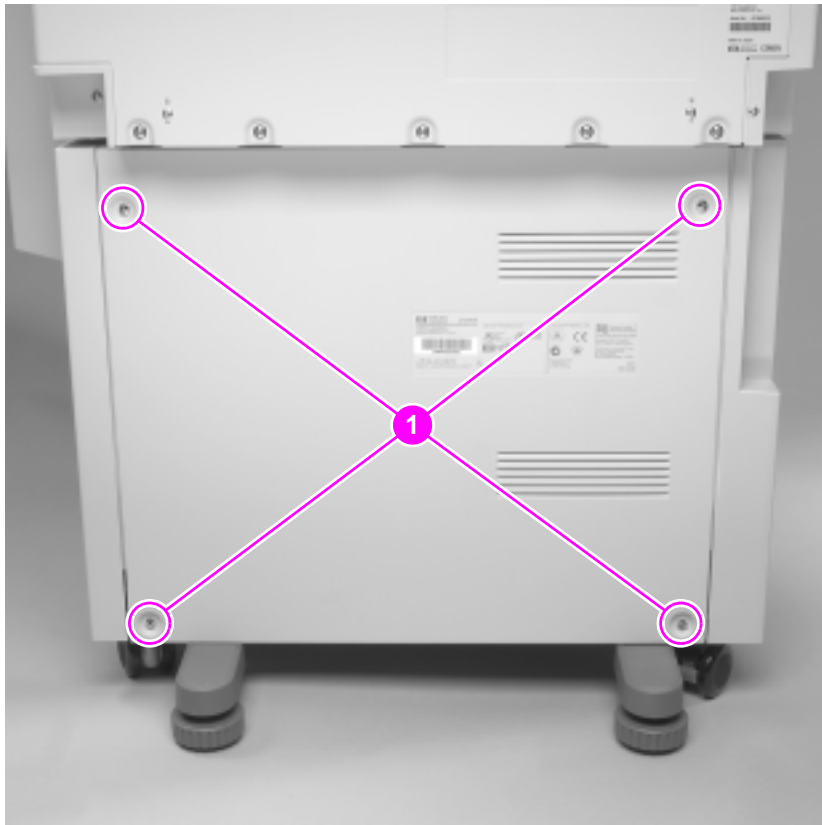
- 3 Remove 4 screws (callout 2).
- 4 Use a flat-blade screwdriver to release the plastic retaining tabs on the left- and right-front sides of the tray (callout 3).
- 5 Carefully lift up on the front cover, and then pull it out to release the plastic retaining tabs that secure the bottom of the front cover to the tray chassis.

### Notes on reinstalling:

- Ensure the plastic retaining tabs are replaced properly.

## Back cover

- 1 Unplug the power cord and the C-link interface cables from the 2,000-sheet input unit.
- 2 Remove 4 screws (callout 1).



**Figure 142.** Back cover removal

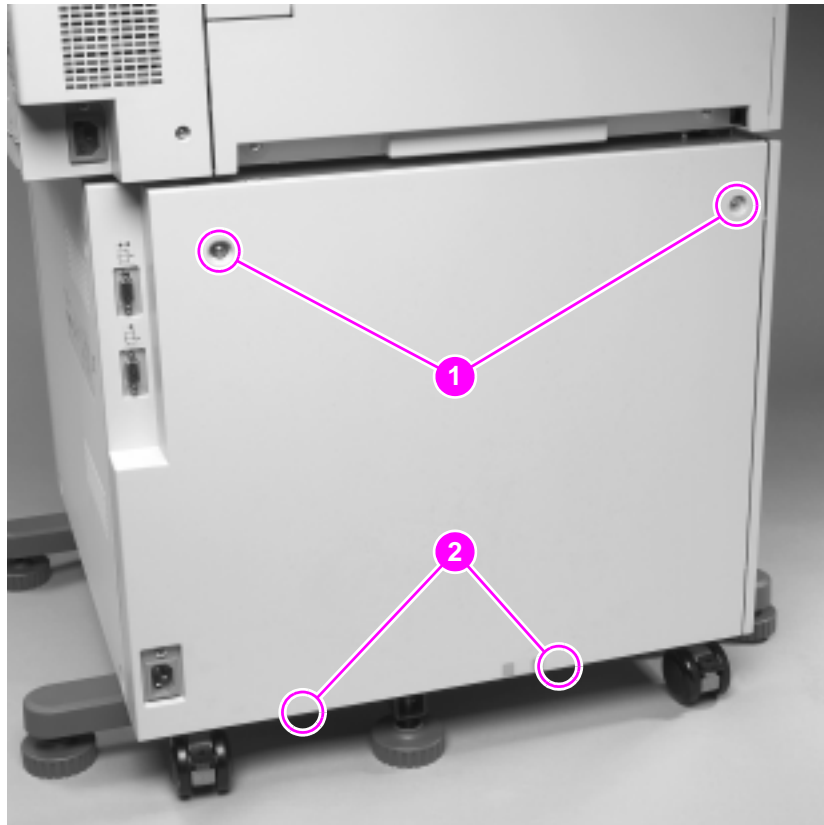
- 3 Pull the cover back from the chassis.

### Notes on reinstalling:

- Make sure the tab on the lower-left corner is inserted into its alignment slot.

## Left cover

- 1 Unplug the power cord and the C-link interface cables from the 2,000-sheet input unit.
- 2 Remove 2 screws (callout 1).



**Figure 143.** Left cover removal

- 3 Pull out on the top of the cover, and then lift up on the right side of the cover to clear the retaining tabs that are along the bottom edge (callout 2).
- 4 Pull out on the lower-left corner to release the plastic retainer tab that secures that corner of the cover to the chassis.

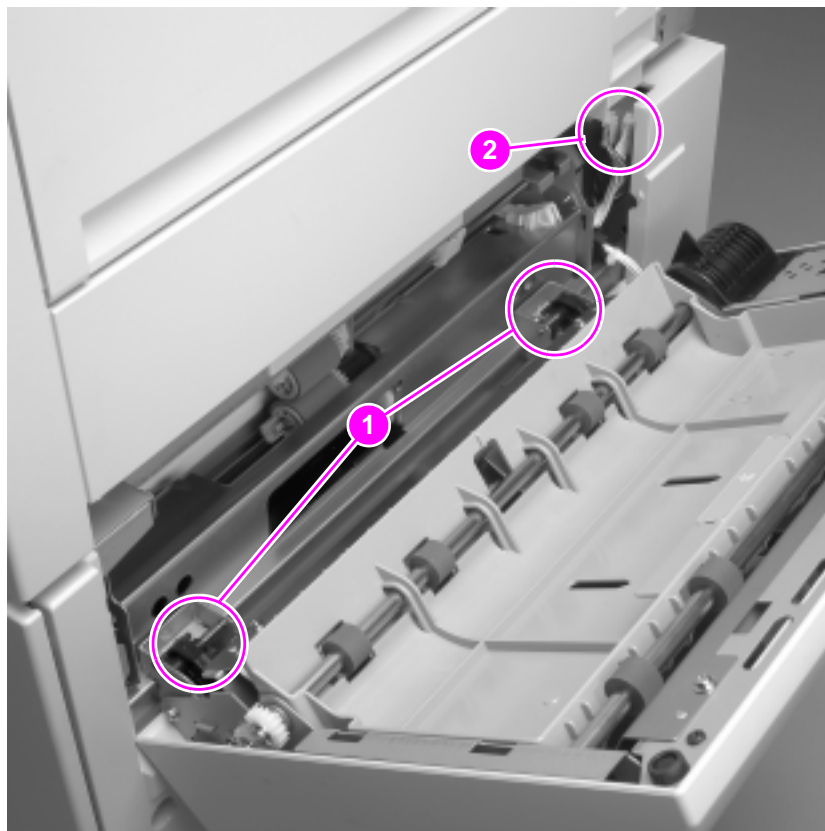
### Notes on reinstalling:

- Replace the left side first.
- Tilt the right side down and toward the chassis to place the lower retaining tabs over the chassis rail (callout 2).

## Vertical transfer unit (VTU)

Remove the VTU to access the left side of the unit and the paper path mechanisms.

- 1 Unplug the power cord and the C-link interface cables from the 2,000-sheet input unit.
- 2 Open the VTU.
- 3 Rotate the 2 plastic safety catches on the VTU hinges towards the unit to the “open” position (callout 1).



**Figure 144.** Vertical transfer unit (VTU)

### **WARNING!**

*Do not* release the safety catches from the “open” position while the VTU is removed. The springs on the safety catches are very strong and can cause injury.

- 4 Unplug 2 connectors (callout 2).
- 5 Remove 2 screws, one on the inner side of each safety catch.

- 6 Pull the door halfway closed, then lift the unit straight up to clear the metal locating tabs on the chassis.

**Notes on reinstalling:**

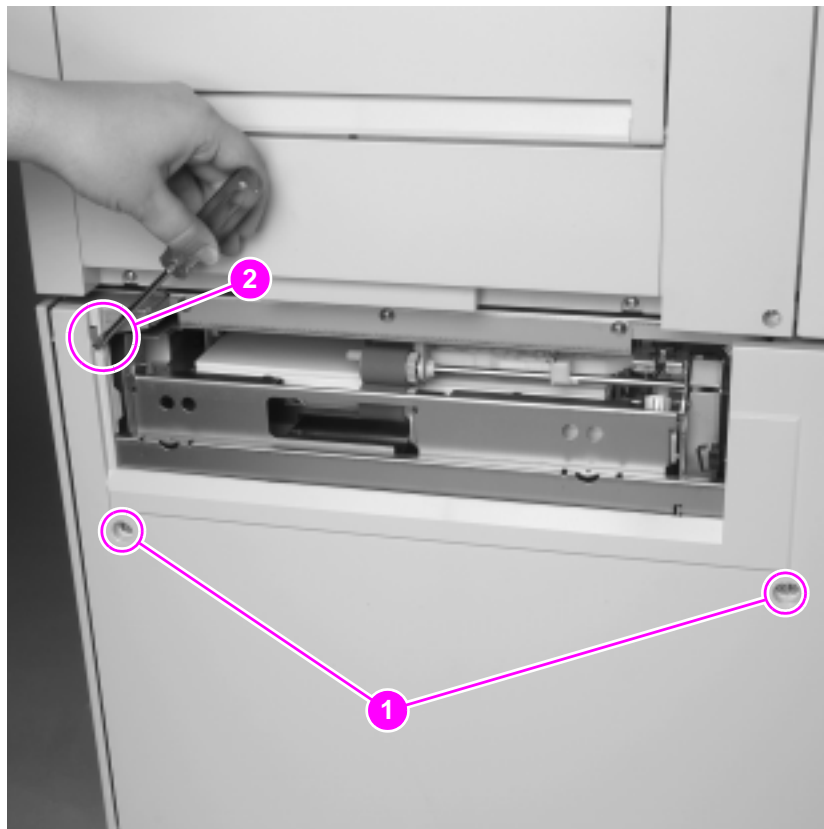
- Before tightening the screws, ensure that the metal locating tabs are in place.

**WARNING!**

Release the safety catches only *after* tightening the screws that secure the VTU to the chassis.

## Right cover

- 1 Remove the vertical transfer unit (VTU) (see page 275).
- 2 Remove the 2 screws near the middle of the right cover (callout 1).



**Figure 145.** Right cover with VTU removed

- 3 Using a flat-blade screwdriver, release the plastic retaining tab on

the upper-left corner of the cover (callout 2).

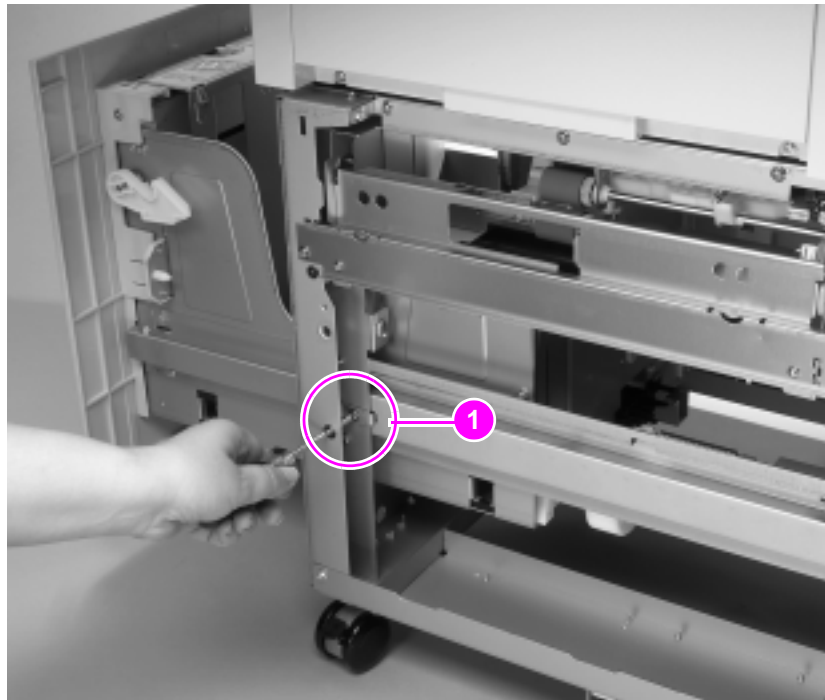
- 4 Carefully pull out on the top of the cover while lifting it upward to clear the retaining tabs that are along the cover's bottom edge.

**Notes on reinstalling:**

- Make sure the retaining tabs that are along the cover's bottom edge are placed over the chassis rail.

## Tray 4

- 1 Open tray 4 and remove any paper.
- 2 Remove the vertical transfer unit (VTU) (see page 275).
- 3 Remove the left and right covers (see page 274 and page 276).
- 4 Remove 1 screw and 1 metal retaining tab from each side of the chassis (callout 1).



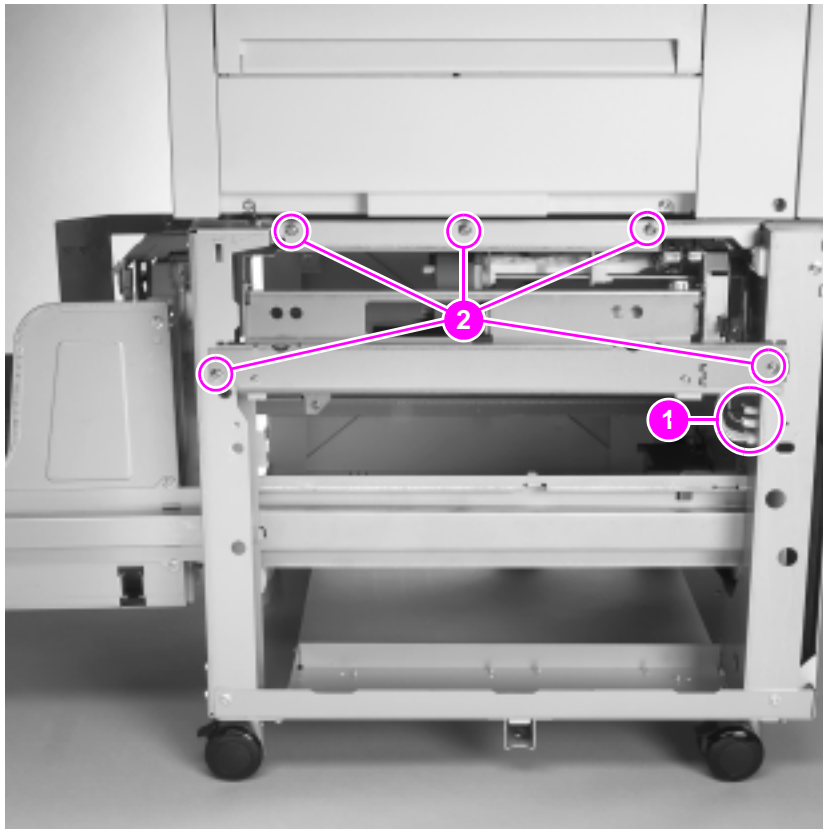
**Figure 146.** Tray 4 removal

- 5 Support the rear of the tray while sliding it straight out of the chassis.

## Paper pick-up assembly

The paper pick-up assembly is located on the right side of the unit.

- 1 Remove the VTU (see page 275).
- 2 Remove the right cover (see page 276).
- 3 Open tray 4 to the stops.
- 4 Unplug 3 connectors (callout 1).



**Figure 147.** Paper pick-up assembly

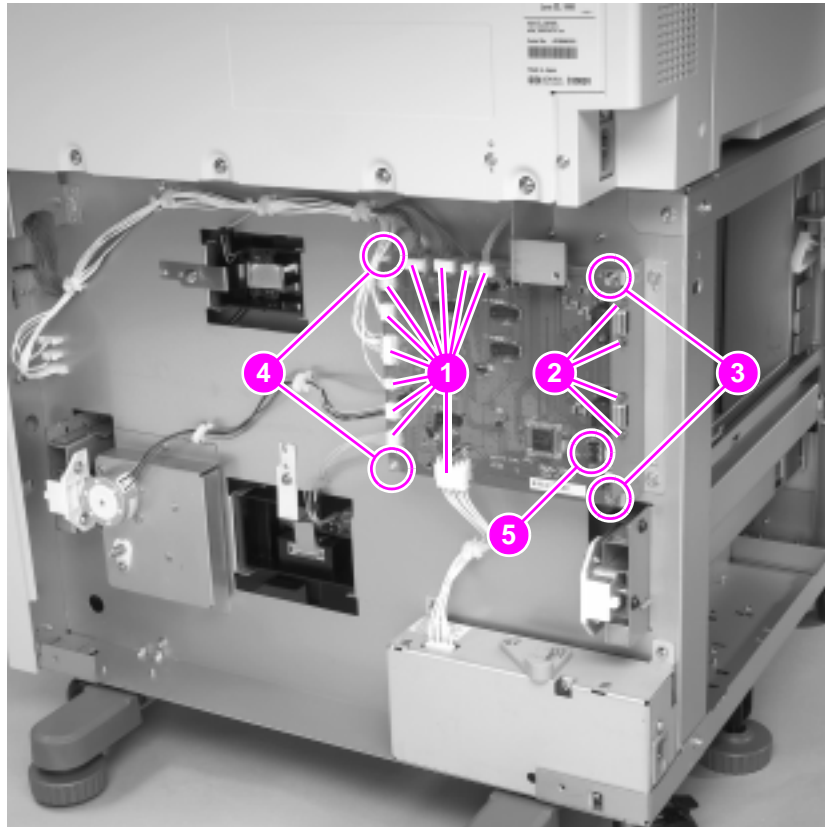
- 5 Remove 5 screws (callout 2).
- 6 Slide the assembly straight out of the chassis.



## Controller PCA

The controller PCA is located on the back of the unit.

- 1 Remove the back and left covers (see page 273 and page 274).
- 2 Unplug 11 connectors (callout 1).



**Figure 148.** Controller PCA

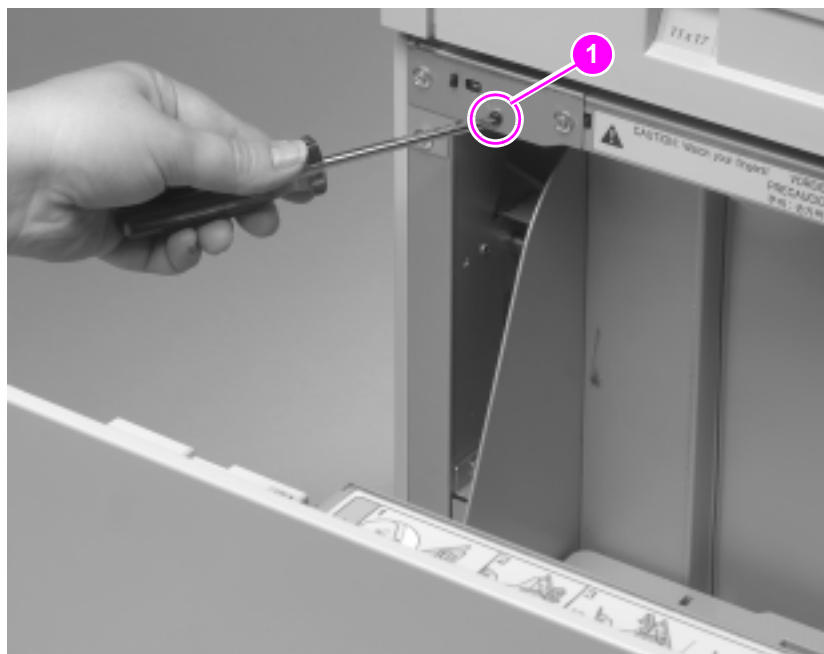
- 3 Remove 4 hex screws from the two C-link cable connectors (callout 2).
- 4 Remove 2 screws from the right side of the PCA (callout 3).
- 5 Release the 2 plastic retaining posts from the left side of the PCA (callout 4).
- 6 Pull the PCA out from the chassis.

**Notes on reinstalling:**

- Ensure that the DIP switches on the PCA are in the Normal Setting (off) (callout 5). For information on DIP switch settings, see page 430.

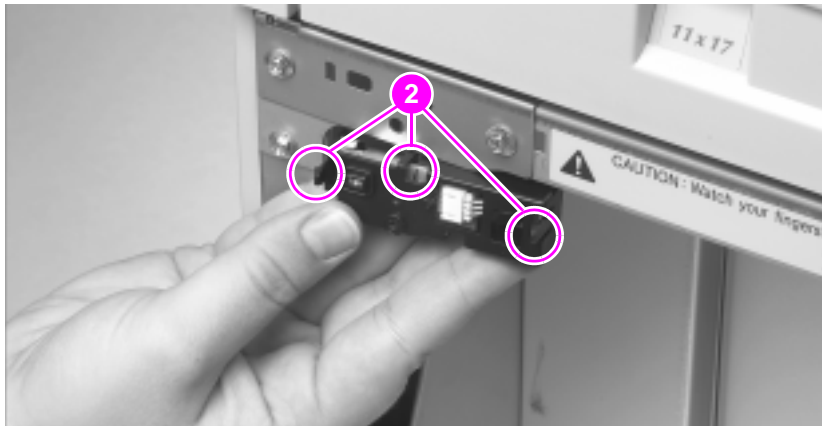
**Front LED PCA assembly**

- 1 Open tray 4 halfway to the stops.
- 2 On the upper-left corner of the front of the chassis, remove 1 screw (callout 1).



**Figure 149.** Screw on front LED PCA assembly

- 3 Reach behind the LED PCA assembly and pull it away from the chassis.
- 4 Release 3 plastic retaining tabs that secure the LED PCA to the connector (callout 2).

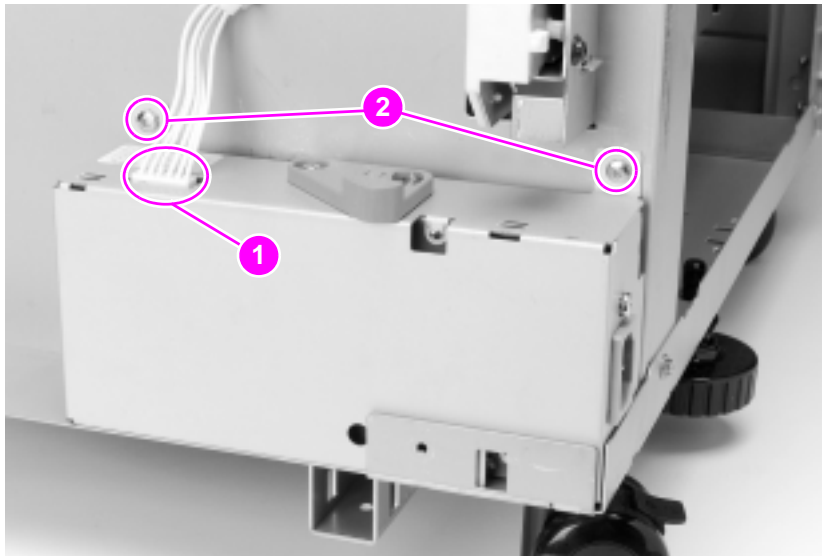


**Figure 150.** Front LED PCA

- 5 Unplug the LED PCA from the connector.

## Power supply

- 1 Unplug the power cord and the C-link interface cables from the 2,000-sheet input unit.
- 2 Remove the back and left covers (see page 273 and page 274).
- 3 Unplug 1 connector (callout 1).

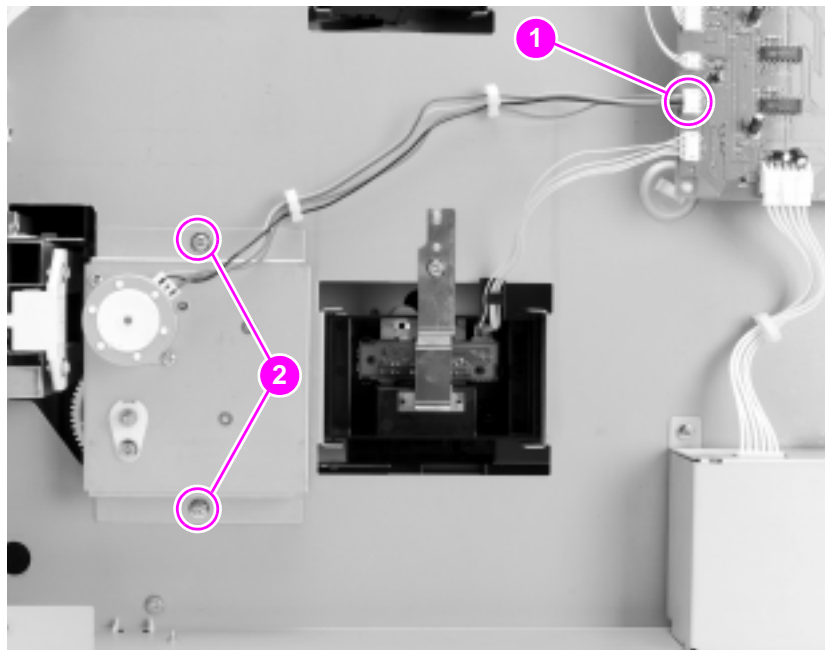


**Figure 151.** Power supply

- 4 Remove 2 screws (callout 2).
- 5 Lift the power supply upward to clear the locating tabs underneath, and then slide it to the left to free it from the chassis.

## Main drive assembly

- 1 Remove the back cover (see page 273).
- 2 Unplug 1 connector from the controller PCA (callout 1).



**Figure 152.** Main drive assembly

- 3 Release 2 cable stays.
- 4 Remove 1 screw on top of the main drive assembly and 1 screw on the bottom (callout 2).
- 5 Pull the main drive assembly away from the chassis.

**Note** Inspect the paper deck drive bushing on the main drive assembly. If the bushing is broken, it can be replaced without replacing the whole drive assembly.

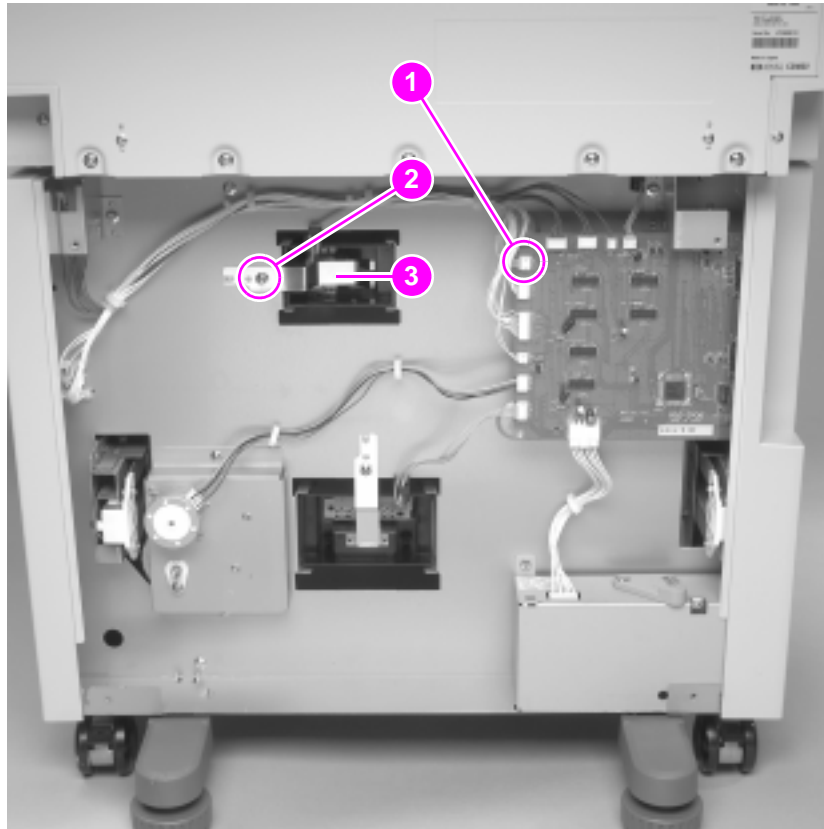


## Paper size sensor assemblies

There are two paper size sensor assemblies: the quantity switch assembly and the paper size switch assembly.

### Removing the quantity switch assembly

- 1 Remove the back cover (see page 273).
- 2 Unplug 1 connector from the controller PCA (callout 1).



**Figure 153.** Paper quantity switch assembly

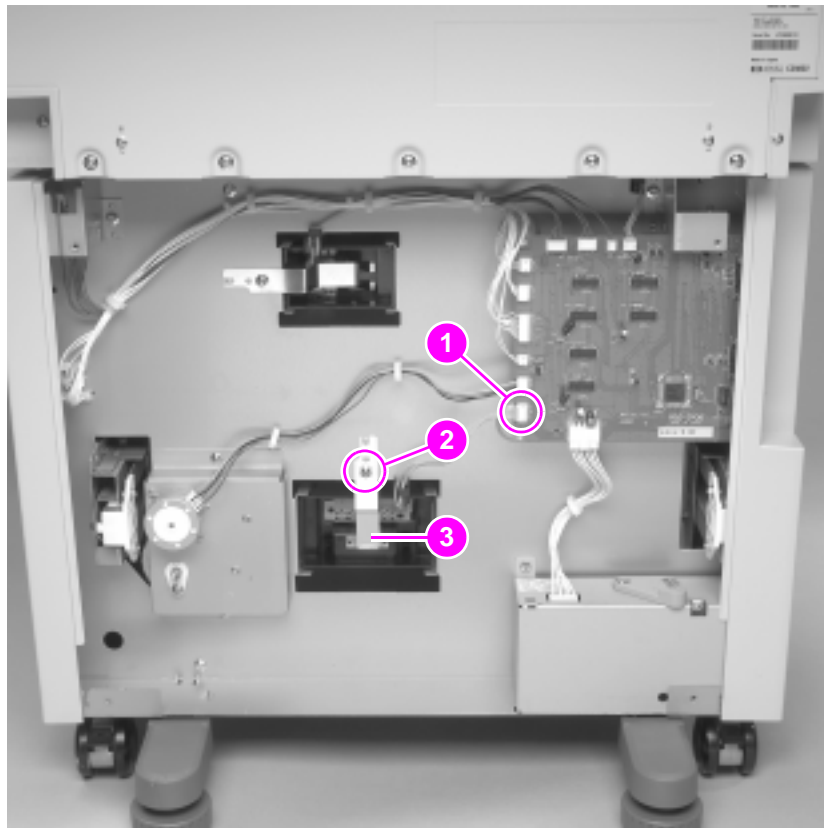
- 3 Release 2 cable stays.
- 4 Remove 1 screw (callout 2) and the metal retaining spring (callout 3) that hold the assembly in place.
- 5 Remove the assembly.

#### Notes on reinstalling:

- Seat the retaining spring (callout 3) onto the locating pins that are on the chassis.

## Removing the paper size switch assembly

- 1 Remove the back cover (see page 273).
- 2 Unplug 1 connector from the controller PCA (callout 1).



**Figure 154.** Paper size switch assembly

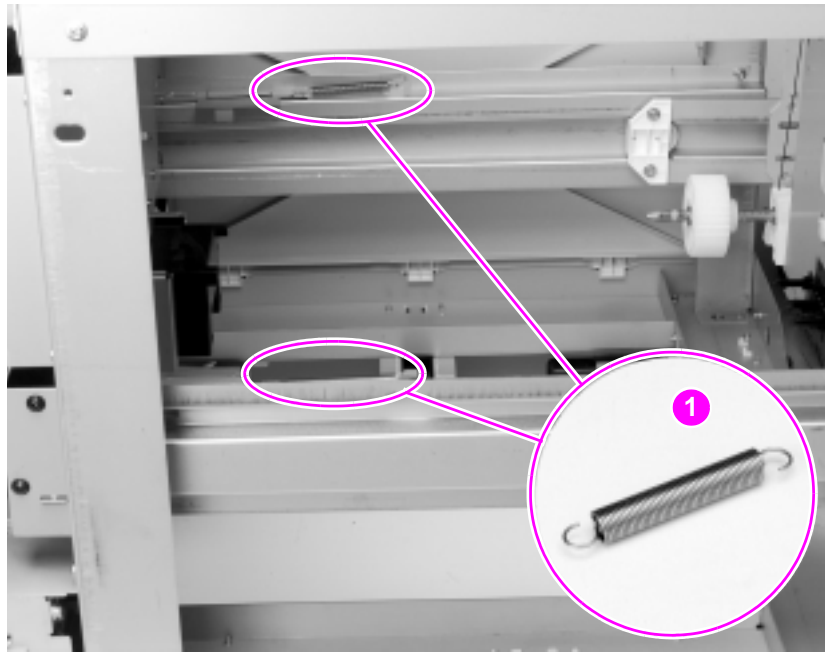
- 3 Remove 1 screw (callout 2) and the metal retaining spring (callout 3) that hold the assembly in place.
- 4 Remove the assembly.

### Notes on reinstalling:

- Seat the retaining spring (callout 3) onto the locating pins that are on the chassis.

## Tension springs

- 1 Remove the left cover (see page 274).
- 2 Open tray 4 to the stops.
- 3 Inside the tray, remove 1 spring on the left runner and 1 spring on the right runner (callout 1).



**Figure 155.** Tension springs

## Multi-bin mailbox

The following covers and assemblies can be removed from the multi-bin mailbox:

- front, back, and top covers
- power supply
- paper bins and blind cover
- flipper assembly
- delivery head position motor
- transport belt motor
- input paper guide
- metallic tape and housing assembly
- controller PCA
- anti-curl strings
- delivery head assembly
- interlock switch
- diagnostic LED PCA
- user status LED PCA
- attachment assembly

---

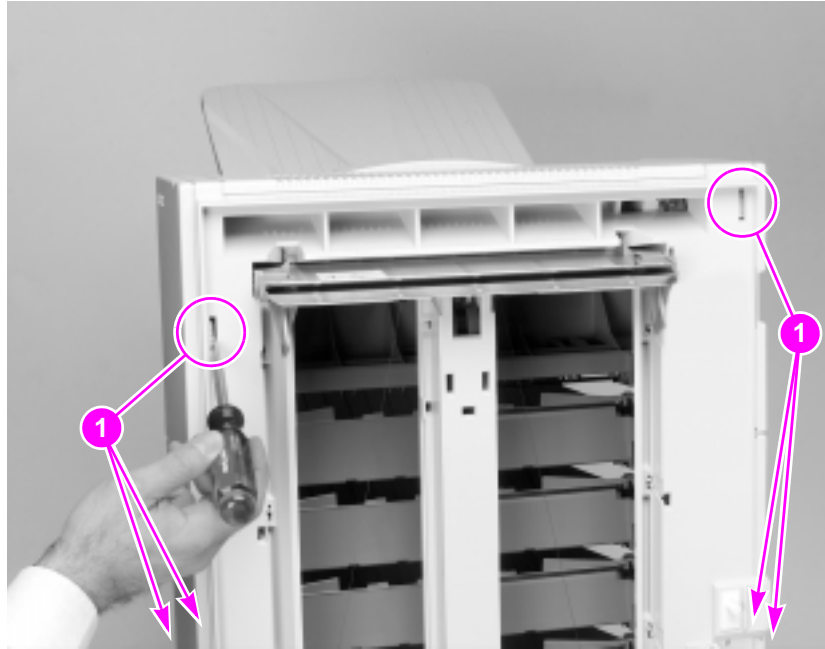
### Hint

Place the multi-bin mailbox on a table for ease in servicing the unit.



## Front and back covers

- 1 Remove the multi-bin mailbox from the printer.
- 2 For each cover, use a small flat-blade screwdriver to release the 3 retaining tabs that secure the cover to the frame (callout 1).

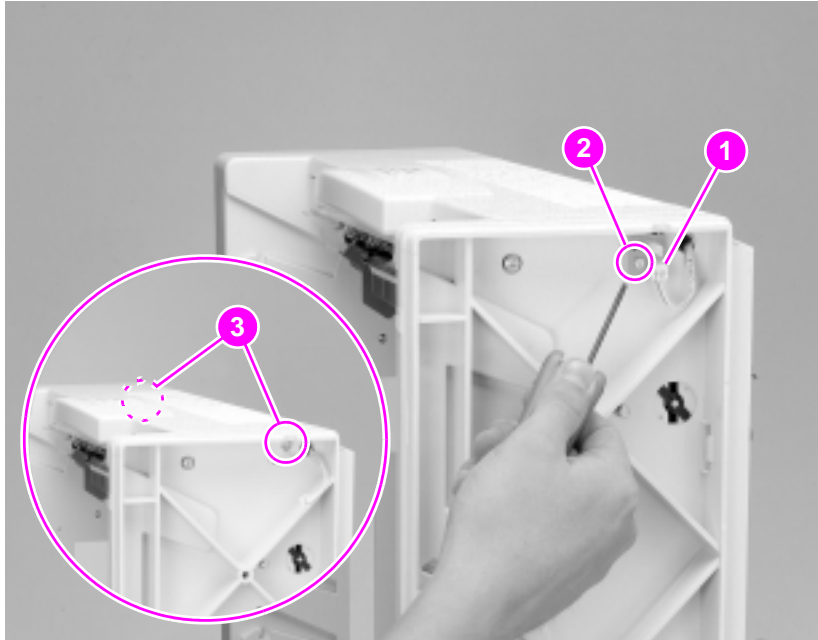


**Figure 156.** Front and back covers

- 3 Rotate the cover outward to release it from the frame.

## Top cover

- 1 Remove the front and back covers (see page 287).
- 2 Disconnect the cable from the LED PCA (callout 1, at the upper-front side of the frame).

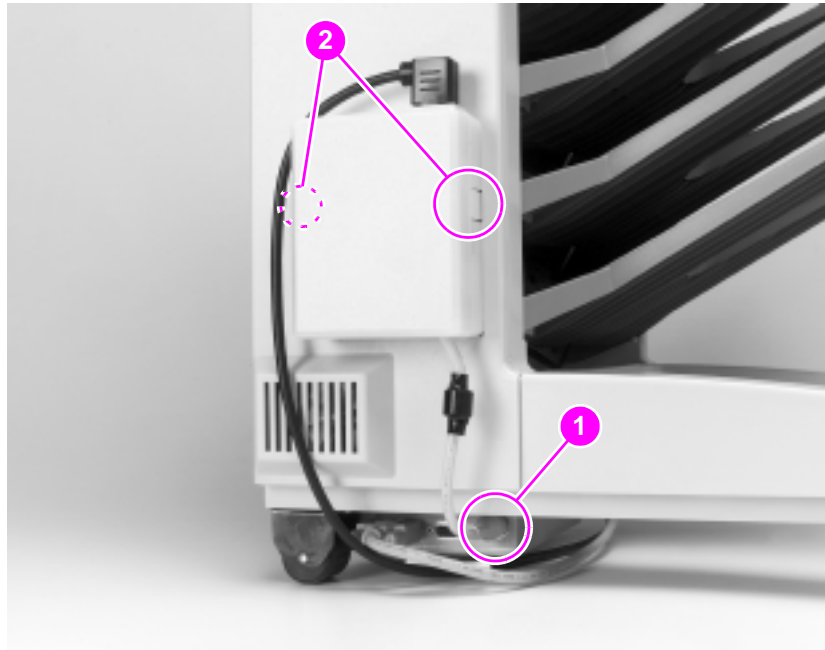


**Figure 157.** Top cover

- 3 Remove 1 screw that secures the LED PCA to the frame (callout 2).
- 4 Remove 2 screws close to the upper-right side (callout 3).
- 5 Slide the top cover to the left side of the unit, then lift it up and out of the frame.

## Power supply

- 1 Unplug 1 connector from the controller PCA (callout 1).



**Figure 158.** Power supply

- 2 Press the plastic retaining tabs on each side of the power supply to remove it (callout 2).

## Paper bins and blind cover

The procedure for removing the paper bins and the blind cover is the same. Each bin rests in its labeled slot.

- 1 Remove the face-up bin first. Lift the outer edge of the bin to clear the retaining notch in the frame, and then pull the bin away from the frame.
- 2 Remove the blind cover.



**Figure 159.** Paper bins

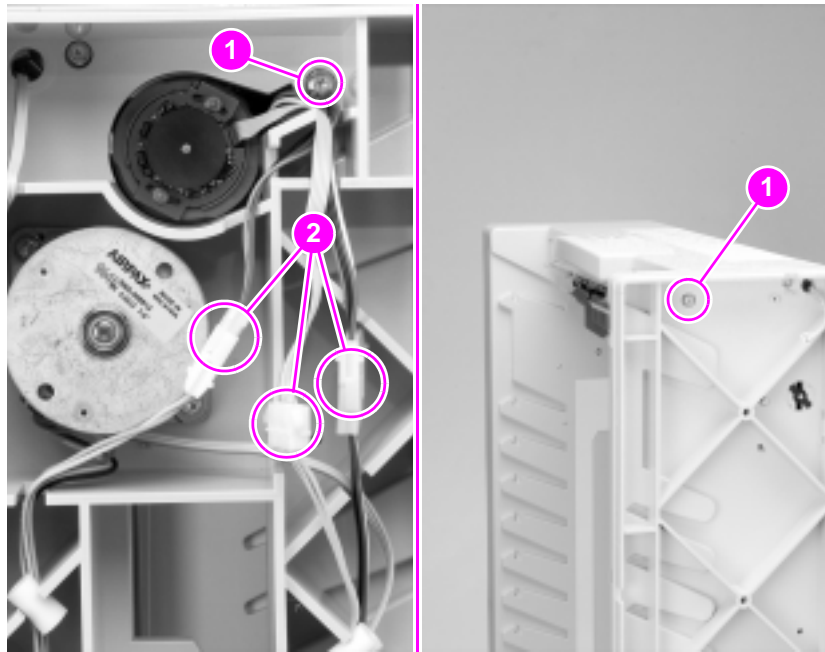
- 3 Remove each face-down bin, starting at the top and working down in sequence.

### Notes on reinstalling:

- Slide a bin into its designated slot, and then lower the bin into the retaining notch in the frame.
- Replace the paper bins, beginning with the bottom face-down bin and continuing upward in order. Be sure to place the blind cover between face-down bin 1 and the face-up bin.

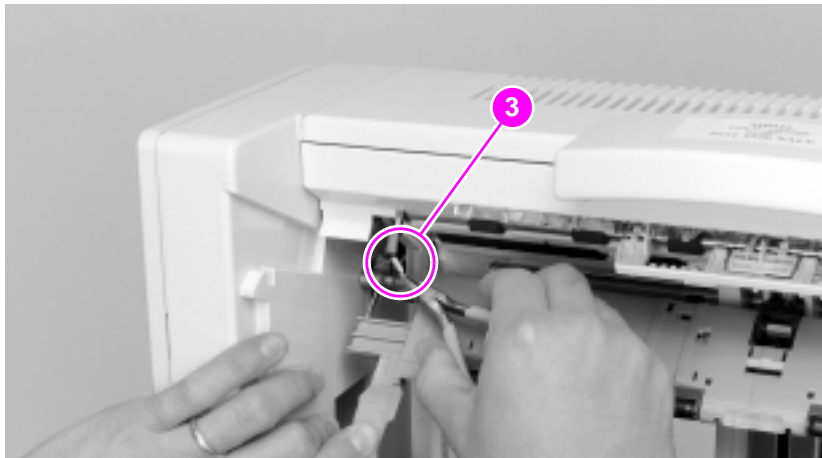
## Flipper assembly

- 1 Remove all paper bins and the blind cover (see page 290).
- 2 Remove the front, back, and top covers (see page 287 and page 288).
- 3 Remove 2 screws closest to the upper-left side (callout 1).



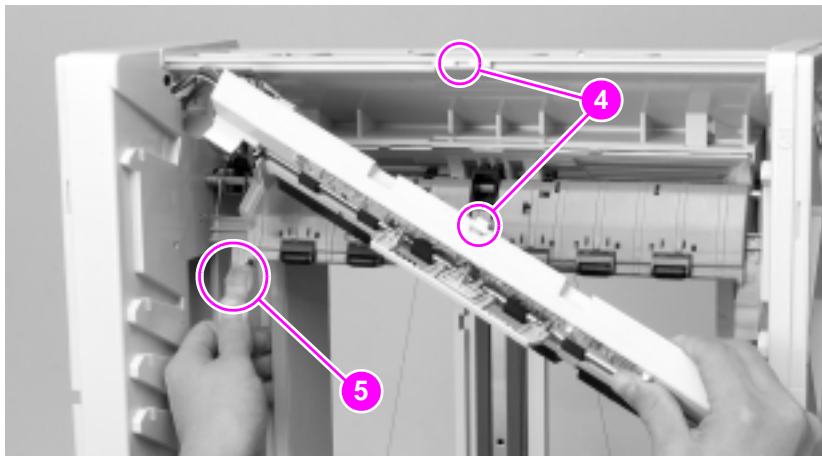
**Figure 160.** Flipper assembly (1 of 3)

- 4 Hold down the jam access door and unplug the ground wire (callout 2) that runs from the input paper guide to the flipper motor.



**Figure 161.** Flipper assembly (2 of 3)

- 5 Unplug 3 connectors (figure 160, callout 3).
- 6 Use a flat-blade screwdriver to release the plastic retaining tab that secures the assembly to the top of the frame (callout 4).



**Figure 162.** Flipper assembly (3 of 3)

- 7 Hold down the jam access door (callout 5) and pull the assembly out.

**Notes on reinstalling:**

- Hold down the jam access door to reconnect the ground wire to the flipper motor (callout 2).

---

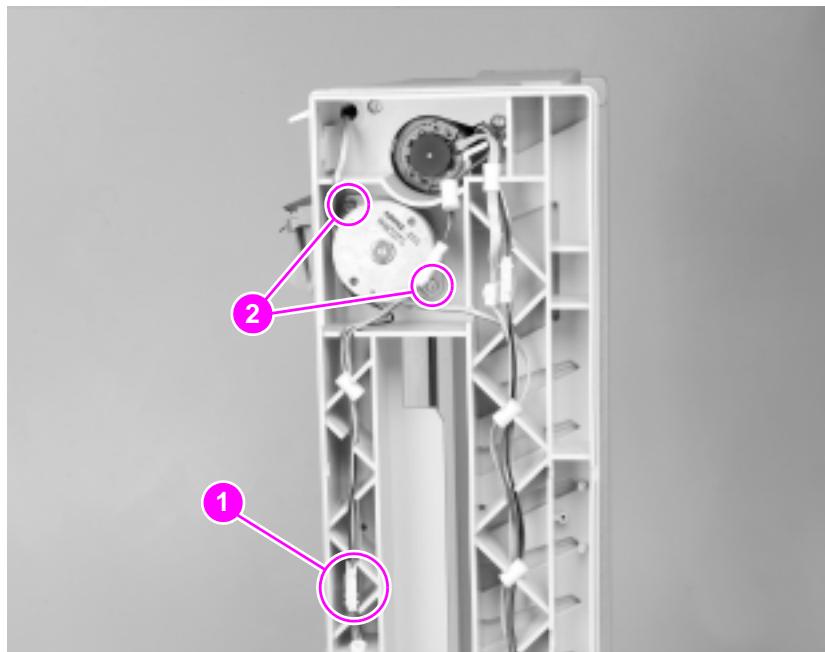
**CAUTION**

---

Do not over-tighten the screws that secure the flipper assembly to the multi-bin mailbox frame. The nuts in the flipper assembly can rotate in their slots.

## Delivery head position motor

- 1 Remove the back cover (see page 287).
- 2 Unplug 1 connector (callout 1).



**Figure 163.** Delivery head motor

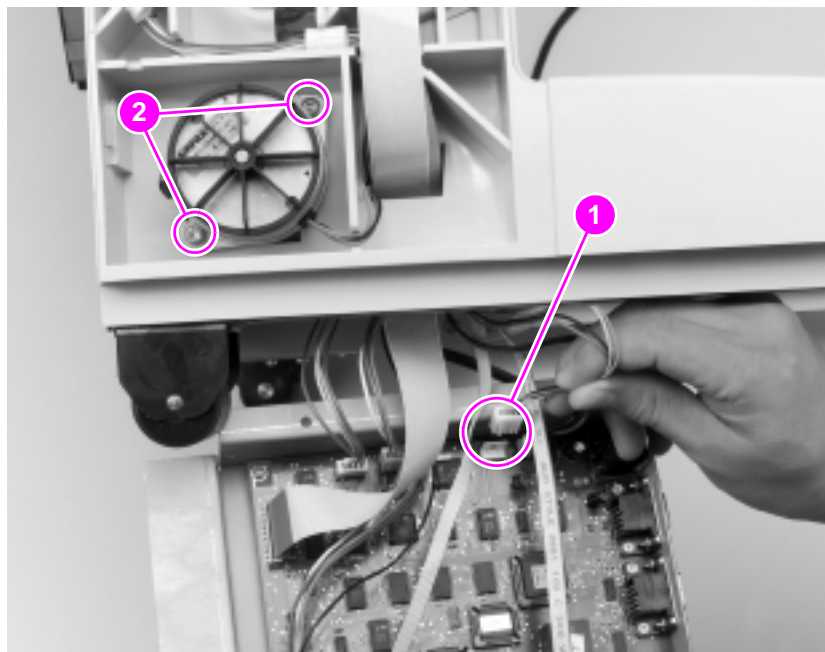
- 3 Remove 2 screws from the motor (callout 2).
- 4 Pull the motor away from the frame.

### Notes on reinstalling:

- Position the motor in the frame so that the cable grommets are face down.

## Transport belt motor

- 1 Remove the back cover (see page 287).
- 2 Remove all paper bins and the blind cover (see page 290).
- 3 Release the controller PCA assembly from the bottom of the frame (see page 299, steps 1 through 7).
- 4 Unplug the J8 connector on the multi-bin mailbox controller PCA (callout 1).



**Figure 164.** Transport belt motor

- 5 Remove 2 screws (and washers) on the transport belt motor (callout 2).

### CAUTION

When removing the motor, be careful not to damage the internal drive belt.

- 6 Gently pull out the motor.

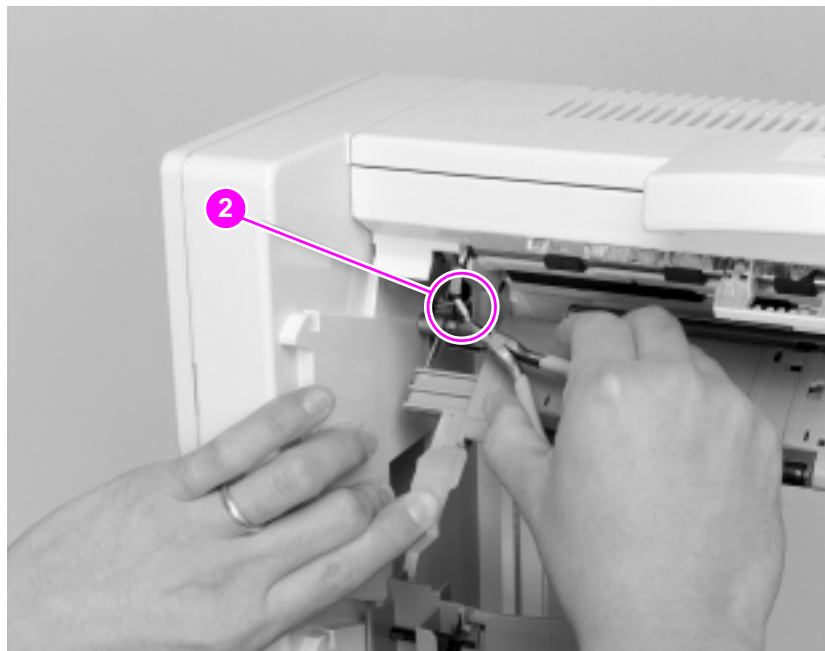


### Notes on reinstalling:

- Reroute the cable on the transport belt motor behind the flat cable, and connect it to the J8 connector on the multi-bin mailbox controller PCA (callout 1).
- Replace the internal drive belt onto the gear of the transport belt motor before replacing the screws that secure the motor to the frame.

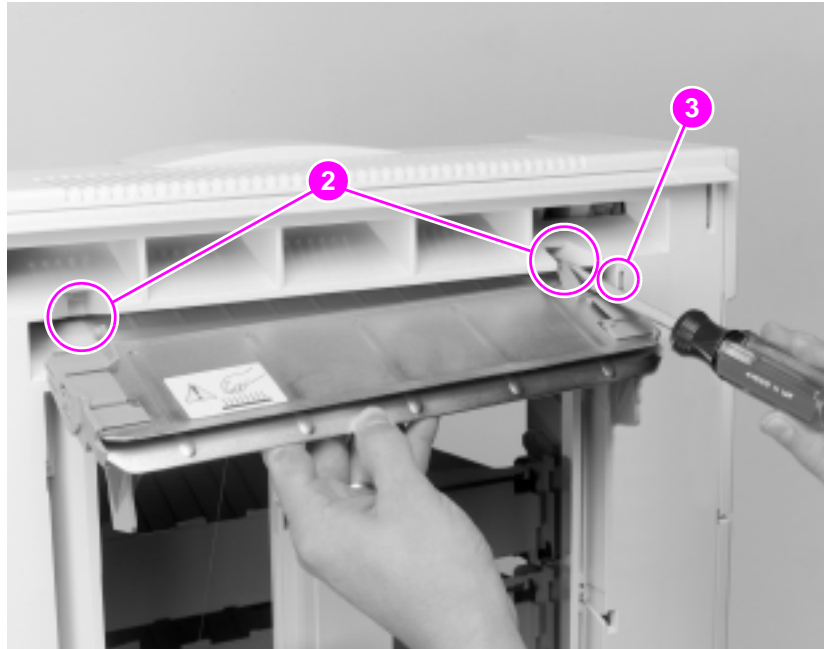
## Input paper guide

- 1 Remove the multi-bin mailbox from the printer.
- 2 Remove the face-up bin and the blind cover (see page 290).
- 3 Hold down the jam access door while unplugging the ground wire (callout 1).



**Figure 165.** Input paper guide (1 of 2)

- 4 Use a flat-blade screwdriver to release the retaining tabs on the top of the input paper guide (callout 2).



**Figure 166.** Input paper guide (2 of 2)

- 5 Pull the input paper guide free of the frame while routing the ground wire through the wire access hole (callout 3).

## Metallic tape and housing assembly

- 1 Remove all paper bins and the blind cover (see page 290).

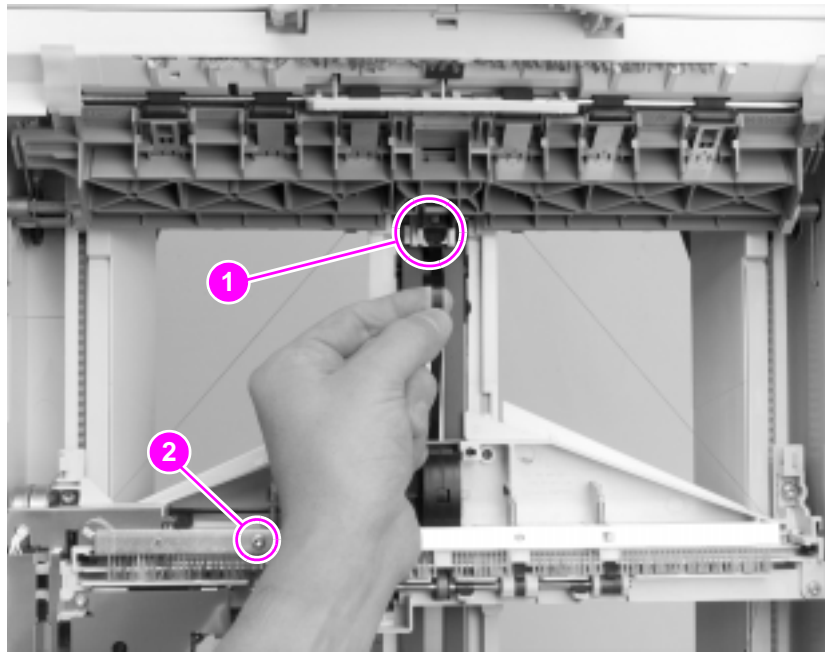
---

**WARNING!**

---

The sharp edges of the metal tape can cause serious injury. When rewinding the metal tape into its housing, hold the tape securely and rewind it slowly.

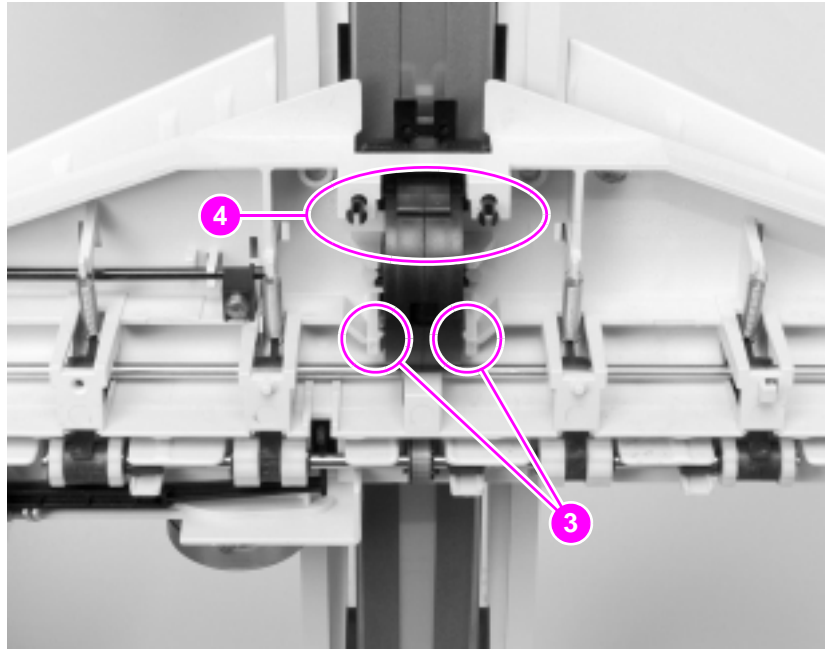
- 2 With the delivery head assembly at the top of the multi-bin mailbox, hold the metal tape near the end, and push and release the retainer tab that secures the end of the tape to the top of the frame (callout 1). Then let the tape slowly rewind into its housing.



**Figure 167.** Metallic tape and housing assembly (1 of 2)

- 3 Remove 1 screw from the static brush (callout 2), and then move the static brush out of the way.
- 4 Lower the delivery head assembly halfway to the stops.

- 5 Use a flat-blade screwdriver to release the plastic retaining tabs located on each side of the tape housing (callout 3).



**Figure 168.** Metallic tape and housing assembly (2 of 2)

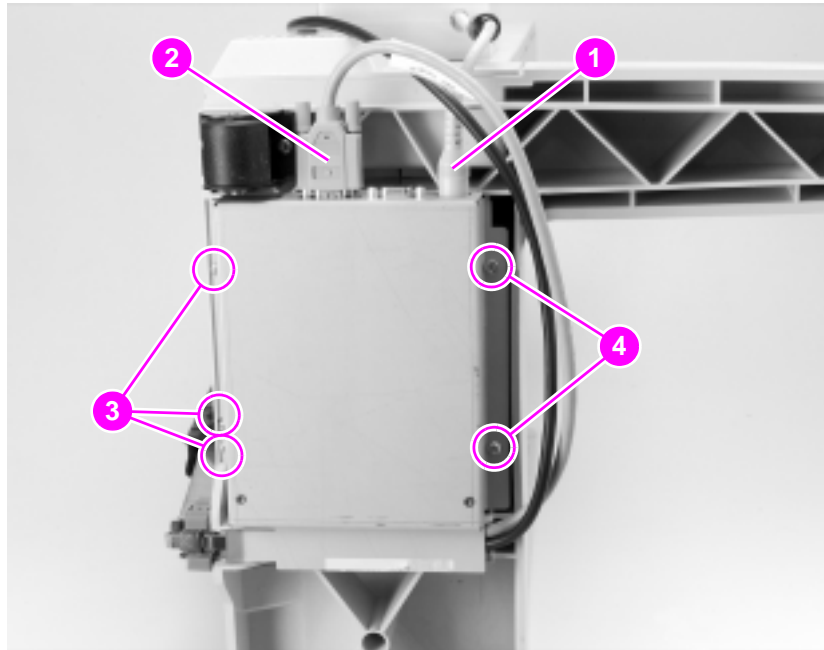
- 6 Gently pull on the delivery head assembly to remove the end of the tape from behind the rollers (callout 4).
- 7 Pull the tape housing toward you to remove it.

**Notes on reinstalling:**

- Thread the end of the metal tape behind the rollers (callout 4), and then pull the end of the tape to the top of the multi-bin mailbox and reinsert it into place (callout 1).
- Use the guide pins to reinstall the tape housing (callout 3). When the housing is correctly positioned, it will click into place.

## Controller PCA

- 1 Disconnect the power cable (callout 1).



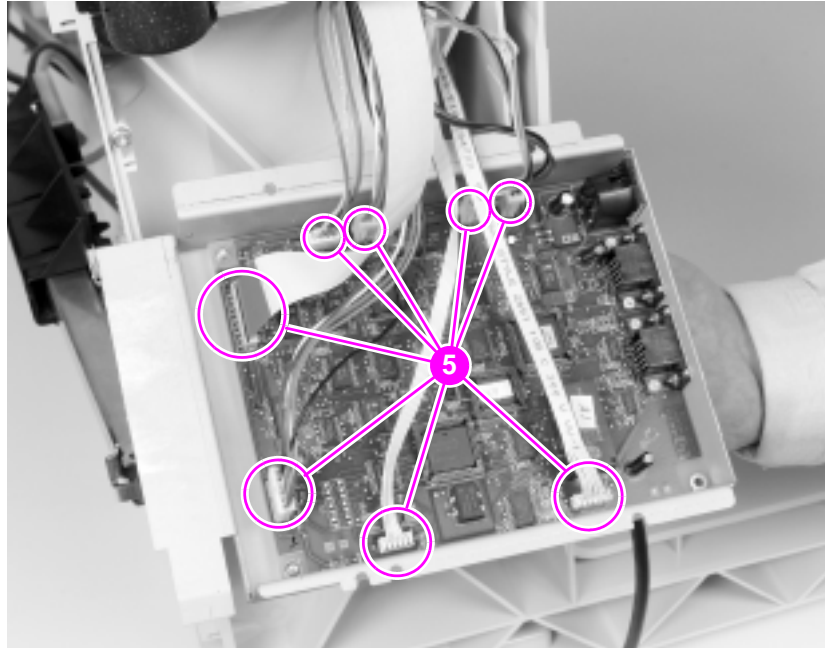
**Figure 169.** Controller PCA (1 of 2)

- 2 Disconnect the C-link cable (callout 2).
- 3 Remove all paper bins and the blind cover (see page 290).
- 4 Carefully lay the multi-bin mailbox on its front side.
- 5 Loosen 1 grounding screw and 2 self-tapping screws on the right side of the PCA cover (callout 3).
- 6 Remove 2 self-tapping screws and the grounding cable from the left side of the PCA cover (callout 4).
- 7 Open the cover to reveal the PCA.

### Notes on reinstalling:

- Reinstall the grounding cable.

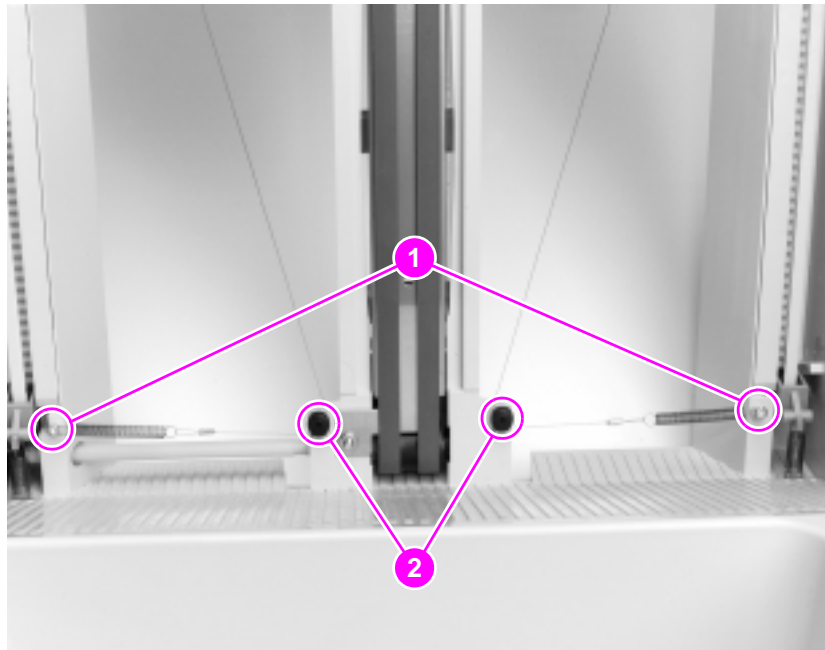
8 Unplug 8 connectors (callout 5) and remove the PCA.



**Figure 170.** Controller PCA (2 of 2)

## Anti-curl strings

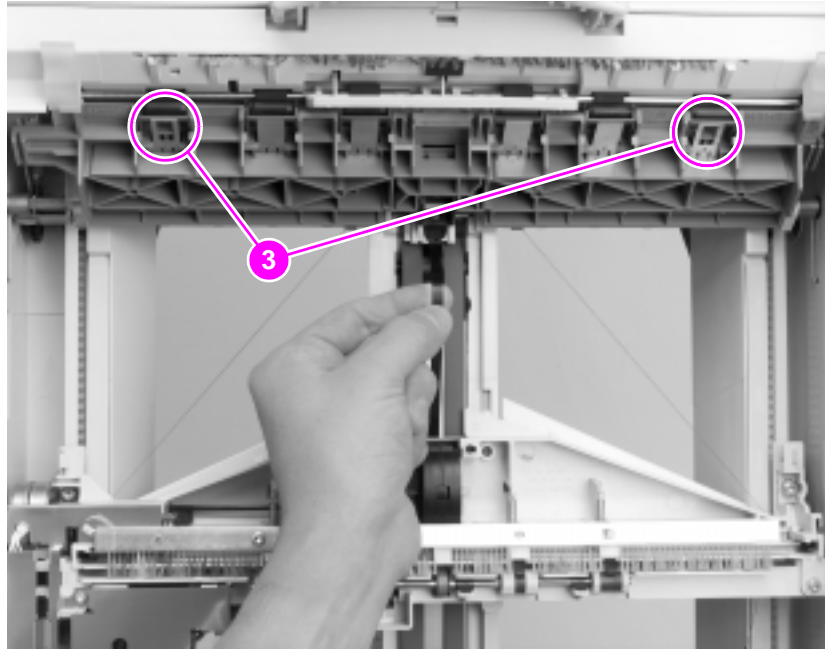
- 1 Remove the back cover (see page 287).
- 2 Remove all the paper bins and the blind cover (see page 290).
- 3 On the lower-left side of the frame, remove 2 screws securing the tension springs (callout 1).



**Figure 171.** Anti-curl strings (1 of 2)

- 4 Remove the anti-curl strings from the lower pulleys (callout 2).
- 5 Remove the delivery head assembly (see page 303).

- 6 Release the upper ends of the anti-curl strings from the jam access door by pushing the retaining tabs that secure the strings to the door (callout 3).



**Figure 172.** Anti-curl strings (2 of 2)



## Delivery head assembly

- 1 Remove the back cover (see page 287).
- 2 Remove all paper bins and the blind cover (see page 290).

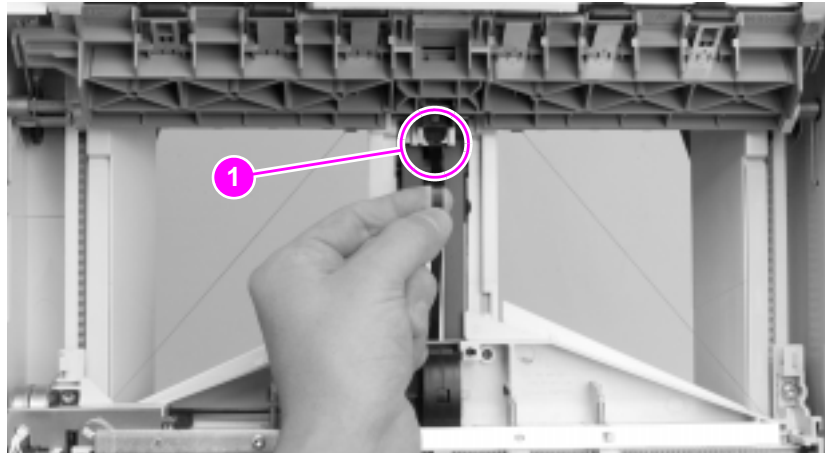
---

### WARNING!

---

The sharp edges of the metal tape can cause serious injury. When rewinding the metal tape into its housing, hold the tape securely and rewind it slowly.

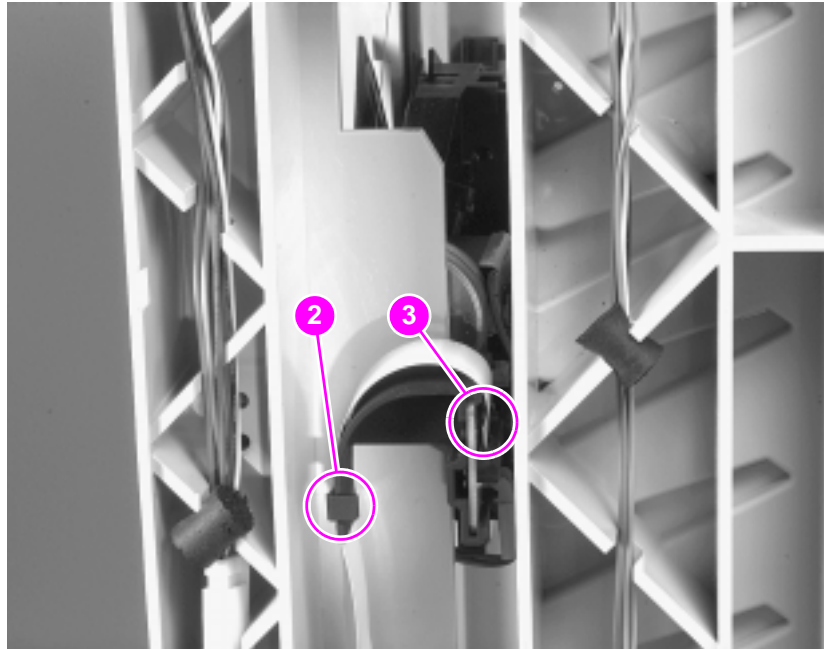
- 3 With the delivery head assembly at the top of the multi-bin mailbox, hold the metal tape near the end, and release the retainer tab that secures the end of the tape to the top of the frame (callout 1). Then let the tape slowly rewind into its housing.



**Figure 173.** Delivery head assembly (1 of 4)

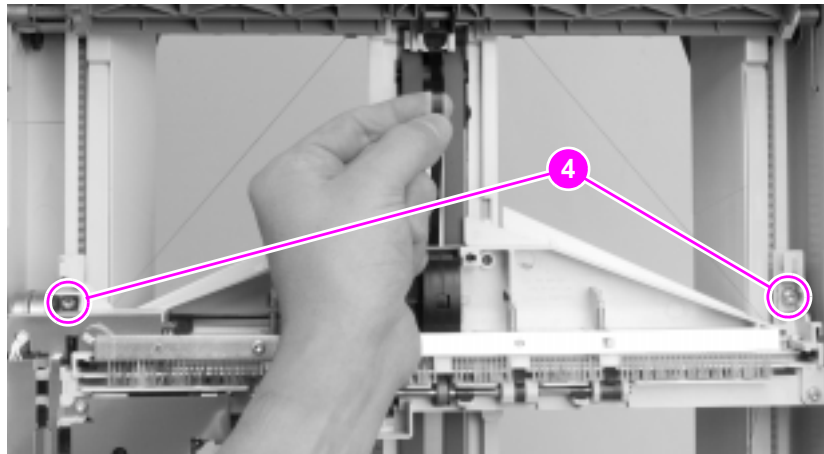
- 4 Remove the anticurl strings (see page 301).

- 5 Release the flat ribbon cable from the cable clip (callout 2), and gently disconnect the cable (callout 3).



**Figure 174.** Delivery head assembly (2 of 4)

- 6 Raise the assembly to the top of the frame.
- 7 Hold up the assembly and remove 2 screws (callout 4).

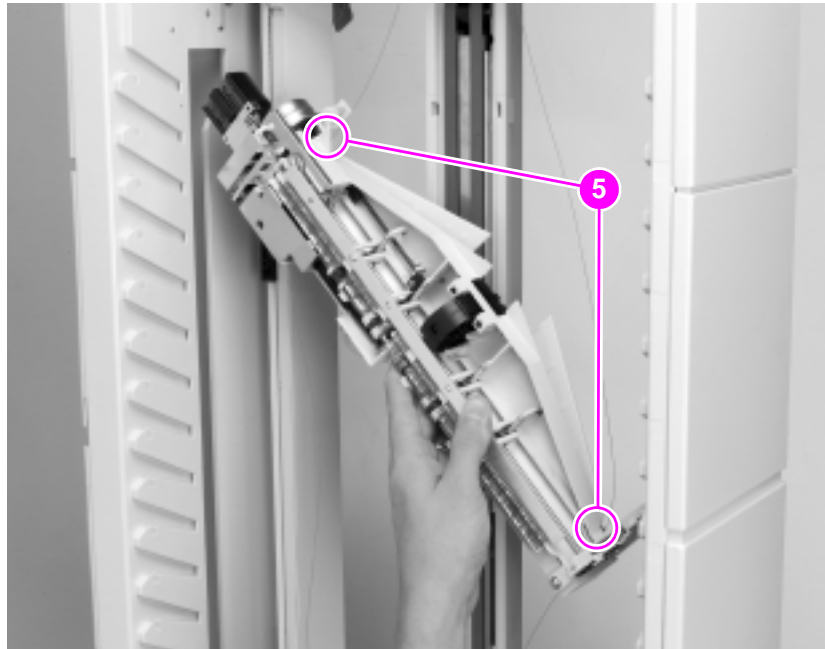


**Figure 175.** Delivery head assembly (3 of 4)

**Note**

The screw that secures the back end is captive.

- 8 Rotate the assembly clockwise while guiding the back end out of its access opening (see figure 176).
- 9 Release the anti-curl strings from the pulleys on each end of the assembly (callout 5).



**Figure 176.** Delivery head assembly (4 of 4)

**Notes on reinstalling:**

- When reinstalling the assembly onto its elevator mounts, ensure that the locating pins are in place.
- Ensure that the assembly moves up and down freely.

## Interlock switch

- 1 Remove the back cover (see page 287).

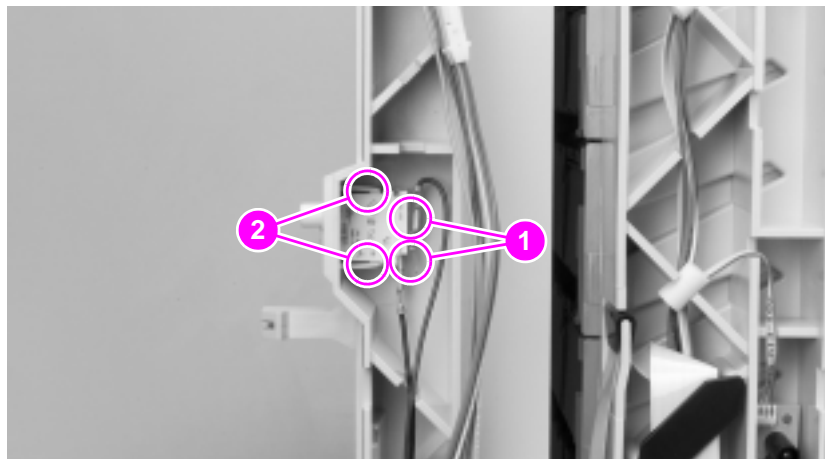
---

### CAUTION

---

Before removing the wires from the multi-bin mailbox interlock switch, note the location of each wire. Replacing the wires incorrectly can damage the interlock switch.

- 2 Disconnect 2 wires from the switch (callout 1).

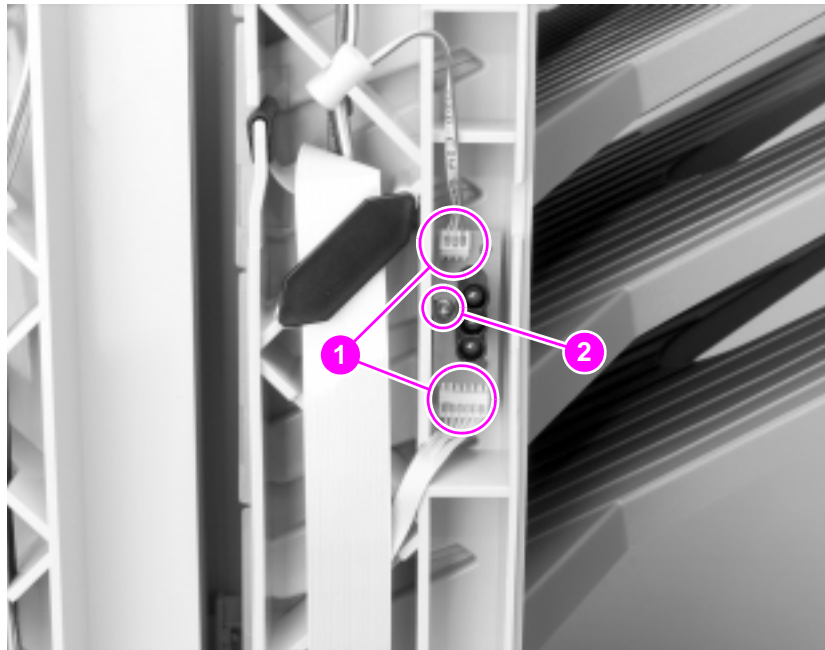


**Figure 177.** Interlock switch

- 3 Press the 2 retaining tabs together to remove the switch (callout 2).

## Diagnostic LED PCA

- 1 Remove the back cover (see page 287).
- 2 Unplug 2 connectors from the PCA (callout 1).



**Figure 178.** Diagnostic LED PCA

- 3 Remove 1 screw (callout 2).
- 4 Pull the PCA away from the frame.

## User status LED PCA

- 1 Remove the front cover (see page 287).
- 2 Disconnect the cable from the PCA (callout 1).

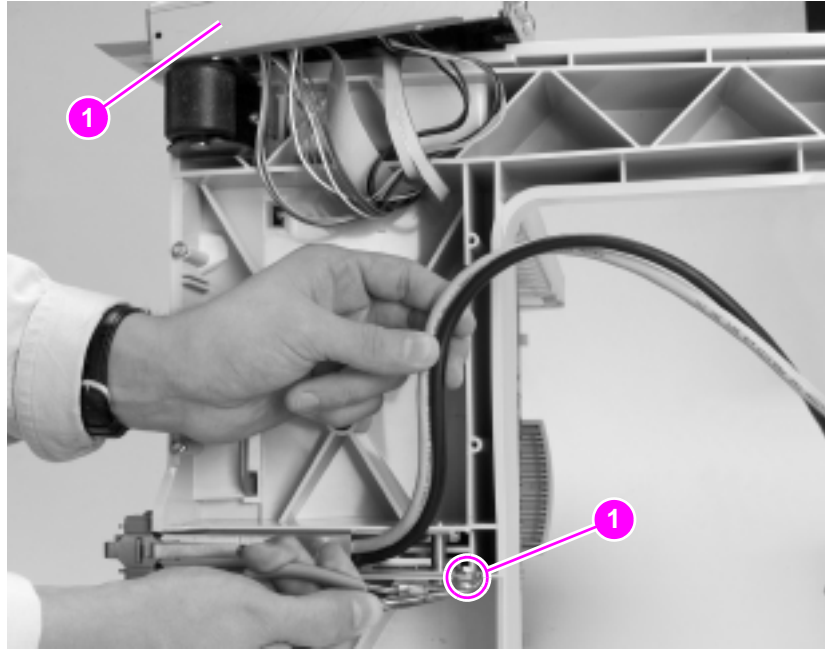


**Figure 179.** User status LED PCA

- 3 Remove 1 screw (callout 2).
- 4 Pull the PCA away from the frame.

## Attachment assembly

- 1 Remove the controller PCA, but leave cables connected (see page 299).
- 2 Set the controller PCA on top of the unit (callout 1).



**Figure 180.** Attachment assembly

- 3 Remove the e-ring (callout 2).
- 4 Release the pivot pin that holds the attachment assembly rod to the frame.
- 5 Remove the assembly.





# 7 Troubleshooting

## Chapter contents

Pre-troubleshooting checklist . . . . .	315
Printer message troubleshooting. . . . .	316
Aids to troubleshooting . . . . .	361
Configuration page . . . . .	361
Continuous configuration page . . . . .	363
Demonstration page . . . . .	364
Event log . . . . .	364
Service mode engine diagnostics . . . . .	365
Disabling interlocks . . . . .	370
Service mode formatter diagnostics . . . . .	375
Cold reset . . . . .	376
Fault log. . . . .	377
Paper path troubleshooting. . . . .	378
General paper path checklist. . . . .	378
Wrinkled pages . . . . .	378
Sealed envelopes . . . . .	379
Media jams . . . . .	379
Image formation troubleshooting. . . . .	383
Understanding color variations . . . . .	384
Common causes of color variation . . . . .	384

Image defects troubleshooting . . . . .	386
Image orientation . . . . .	386
Image defect examples . . . . .	387
Incorrect registration (late and early print) . . . . .	399
Image skew . . . . .	399
Blank or partially blank page . . . . .	400
Horizontal streaks (in one color) . . . . .	401
Horizontal streaks (in all colors, CMYK) . . . . .	402
Rain . . . . .	403
Speckled print . . . . .	403
Smear print . . . . .	404
Print on back of page (non-duplexed page) . . . . .	405
Poor fusing . . . . .	405
Ghosting . . . . .	406
Black, brown, or orange bands . . . . .	407
Background toner scatter . . . . .	407
Yellow or black streaks . . . . .	408
Mottled process colors or poor transfer . . . . .	408
Faint print . . . . .	409
Stray toner . . . . .	410
Banding (less than 10 mm) . . . . .	411
Banding (14 mm) . . . . .	411
Overhead transparency defects . . . . .	412
Dark yellow print or contaminated print . . . . .	413
Color balance adjustment . . . . .	414

Repetitive defects troubleshooting . . . . .	419
Color developer roller . . . . .	421
Charging roller . . . . .	421
Black developer roller . . . . .	421
Cleaning roller . . . . .	421
Developer DSD wheels . . . . .	421
Transfer roller . . . . .	422
Transfer drum . . . . .	422
Fuser . . . . .	424
Imaging drum . . . . .	424
Transfer belt . . . . .	425
2,000-sheet input unit troubleshooting . . . . .	426
Ways to troubleshoot the unit . . . . .	426
Status LED descriptions . . . . .	427
Service LED descriptions . . . . .	428
Standalone running test . . . . .	430
Motor test . . . . .	431
Sensor test . . . . .	432
Multi-bin mailbox troubleshooting . . . . .	434
Switching the multi-bin mailbox to test mode . . . . .	434
Power-up sequence test . . . . .	435
Paper path test . . . . .	435
Multi-bin mailbox LED descriptions . . . . .	436
Communications troubleshooting . . . . .	439
HP network interface support . . . . .	439
Third-party network interface support . . . . .	439
Diagrams . . . . .	440



## Pre-troubleshooting checklist

Before troubleshooting any specific printer problem, ensure that:

- The failure is associated with the printer before beginning troubleshooting by removing the printer from the network.
- The printer is being powered off with the power button, not by unplugging the printer to ensure the cooling fans run through their entire cycle.
- Any overdue maintenance is performed.
- The maintenance units are within their rated life.

---

### Note

---

The customer is responsible for ensuring that the items included in the consumable kits are in good condition.

- The printer has been maintained on a regular basis as described in chapter 4. Note the location of spilled or accumulated toner before troubleshooting. Toner contamination might indicate ventilation or printer environment problems.
- The customer is using supported media.
- The operating environment is within the specified parameters listed in chapter 1 of this manual.
- The printer is not exposed to ammonia gas such as that produced by diazo copiers or office cleaning materials.
- The printer is never exposed to direct sunlight.
- The media is stored correctly and within environmental limits.
- The printer is installed on a solid, level surface.
- The line voltage does not vary more than 20% from the nominal rated value specified on the Power Rating Label. Suspect this problem if large motors are used near the printer such that they might cause temporary voltage changes.
- Any non-HP components (toner, memory boards, and EIO cards) are removed from the printer.
- Printer hardware or software configuration has not changed, or the problem is not associated with any specific software. Refer customers to their software vendor for software-related problems.

## Printer message troubleshooting

This section contains explanations and recommended actions for messages that appear on the printer control panel.

- **Numbered messages** — Table 39 (beginning on this page)
- **Unnumbered messages (in alphabetical order)** — Table 40 (beginning on page 334)

### Note

The action field for each control panel message describes the steps to resolve the message. Each step is a self-contained resolution for the message; however, the steps should be followed in order.

**Table 39. Numbered printer messages**

*****	<b>Event log message:</b> None
<b>Description:</b> Displayed during startup as the individual tasks begin initializing and during a low-level self-test. A character other than (*) indicates an error has occurred.	<b>Action:</b> No action is required.
<b>20 INSUFFICIENT MEMORY</b>	<b>Event log message:</b> 20.00.00
<b>Description:</b> More data has been received from the computer than fits in the printer's internal memory.	<b>Action:</b> No action is required. Only the amount of data that fits in the printer's internal memory is printed. If this error occurs frequently or if large or complex print jobs are often sent to the printer, add more memory to the printer.
<b>22 EIO &lt;n&gt; BUFFER OVERFLOW</b>	<b>Event log message:</b> 22.00.01
<b>Description:</b> The EIO buffer has overflowed during a busy state. This might happen if several complex jobs are sent simultaneously via the network and are larger than the overflow will allow.	<b>Action:</b> No action is required. The current data in the print buffer will be lost.
<b>&lt;n&gt; = EIO slot number:</b> 1 = Bottom EIO slot 2 = Top EIO slot	

**Table 39. Numbered printer messages (continued)**

<b>22 PARALLEL I/O BUFFER OVERFLOW</b>	<b>Event log message:</b> 22.00.01
<b>Description:</b> Indicates the parallel buffer has overflowed. This might happen if several complex jobs are sent simultaneously via the parallel port and are larger than the overflow will allow.	<b>Action:</b> No action is required. The current data in the print buffer will be lost.
<b>40.&lt;n&gt; HP EIO ERROR</b>	<b>Event log message:</b> 40.00.00
<b>Description:</b> An EIO accessory connection has been abnormally broken while transferring data from the computer to the printer.  <b>&lt;n&gt; = EIO slot number</b> 1 = Bottom EIO slot 2 = Top EIO slot	<b>Action:</b> <ol style="list-style-type: none"><li>1 Print an EIO configuration page to verify that the EIO accessories are installed properly.</li><li>2 Check that all cables are connected to the EIO ports and that the EIO accessory is seated properly.</li><li>3 Turn the printer off and on to reset it.</li><li>4 If possible, print to another network printer to verify the network is working properly.</li></ol> All data in the print buffer will be lost.
<b>41.2 PRINTER ERROR</b>	<b>Event log message:</b> 41.00.02
<b>Description:</b> Indicates that a beam detect laser scanner error has occurred on the previous page. The page will reprint and continue.	<b>Action:</b> <ol style="list-style-type: none"><li>1 Open and close the front door of the printer to remove any remaining pages from the printer.</li><li>2 Turn the printer off and on to reset the printer.</li><li>3 Reconnect connector J1001 on the laser driver PCA and connector J205 on the controller board.</li><li>4 Reconnect connector J2 on beam detect PCA, relay connector J40, and connector J211 on the controller board.</li><li>5 Measure the voltage across connector J211-1 (+5 V) and J211-3 (GND) on the controller board after the printer is turned on. If the voltage is 5 V, replace the laser/scanner unit.</li><li>6 Replace the controller board.</li></ol>

**Table 39. Numbered printer messages (continued)**

<p><b>41.3 UNEXPECTED PAPER SIZE LOAD TRAY 1</b>  <b>&lt;width&gt; &lt;length&gt;</b></p> <p><b>Description:</b>  Tray 1 is configured for a specific media size, but the printer detects a different size being fed from tray 1. For example, the printer was expecting a letter-sized page but detected that an 11-by-17 inch-sized page was fed instead.</p> <p>&lt;width&gt; = Media width specified in the printer driver or application  &lt;length&gt; = Media length specified in the printer driver or application</p>	<p><b>Event log message:</b> 41.00.03</p> <p><b>Action:</b></p> <ol style="list-style-type: none"> <li>1 Verify the correct size paper (width and length) is loaded in tray 1.</li> <li>2 Verify the paper guides are set correctly.</li> <li>3 Load the requested size media in tray 1. Or, press <b>Go</b> to print on the default paper size.</li> <li>4 Verify that the media width sensor on the paper guides are working properly.</li> <li>5 Reconnect connector J1701 on the tray 1 width detection PCA, relay connector J33 and connector J208 on the controller board.</li> <li>6 Replace the tray 1 pick-up assembly.</li> </ol>
<p><b>41.5 UNEXPECTED PAPER TYPE LOAD TRAY &lt;x&gt;</b>  <b>&lt;type&gt; &lt;size&gt;</b></p> <p><b>Description:</b>  The printer was expecting one type of media to be fed from an input tray and a different type was fed. For example, the printer was expecting transparencies and plain paper was fed.</p> <p>&lt;x&gt; = Input tray number (2, 3, or 4)  &lt;type&gt; = Media type specified in the printer driver or application  &lt;size&gt; = Media size specified in the printer driver or application</p> <p><b>Note:</b> The size error in this message applies only to tray 1.</p>	<p><b>Event log message:</b> 41.00.05</p> <p><b>Action:</b></p> <ol style="list-style-type: none"> <li>1 Open and close the front door to remove the page from the printer.</li> <li>2 Verify that the correct media is loaded in the input tray and the printer control panel is configured correctly.</li> <li>3 Clean the detection windows of OHT sensors 1 and 2.</li> <li>4 Reconnect connectors J1801 and J1802 of OHT sensors 1 and 2, connector J214 on the controller board, and relay connector J17.</li> <li>5 Replace OHT sensors 1 and 2.</li> <li>6 Replace the controller board.</li> </ol>
<p><b>49.&lt;xxxx&gt; ERROR CYCLE POWER</b></p> <p><b>Description:</b>  Indicates that a software or data communications error has occurred, or corrupt data was sent to the printer. This can be caused during times of high network traffic or incomplete or out-of-bounds print data. This error can also occur because of defective EIO devices.</p>	<p><b>Event log message:</b> 49.&lt;xxxx&gt;</p> <p><b>Action:</b></p> <ol style="list-style-type: none"> <li>1 Verify that all cables are connected.</li> <li>2 Turn the printer off and on to reset the printer.</li> <li>3 Remove all EIO cards and reinstall them to ensure they are seated correctly.</li> <li>4 If using a parallel connection, verify that the cable is IEEE-1284 compliant.</li> </ol>



**Table 39. Numbered printer messages (continued)**

---

<b>50.1 FUSER ERROR CYCLE POWER</b>	<b>Event log message:</b> 50.00.01
<b>Description:</b> Indicates that a low temperature error has occurred in the fuser.	<b>Action:</b> <ol style="list-style-type: none"><li>1 Verify the fuser is completely seated inside the printer.</li><li>2 Turn the printer off and on to reset the printer.</li><li>3 Turn the printer off and remove the fuser. Measure the resistance across fuser connectors J26F-A4 (FXTHU) and J26F-A3 (GND). If it is not in the range of 250 kOhms to 600 kOhms (room temperature), check the wiring from the connector J222 on the controller board up to the upper thermistor. If the wiring is normal, replace the fuser kit.</li><li>4 Reconnect connector J222 on the controller board and connector J26 on the fuser.</li><li>5 Replace the fuser kit.</li><li>6 Replace the power supply PCA.</li></ol>
<b>50.2 FUSER ERROR CYCLE POWER</b>	<b>Event log message:</b> 50.00.02
<b>Description:</b> Indicates that a warmup error has occurred in the fuser.	<b>Action:</b> <ol style="list-style-type: none"><li>1 Turn the printer off and on to reset the printer.</li><li>2 Verify the fuser is completely seated inside the printer.</li><li>3 Check for media jams in the fuser.</li><li>4 Replace the fuser kit.</li></ol>
<b>50.3 FUSER ERROR CYCLE POWER</b>	<b>Event log message:</b> 50.00.03
<b>Description:</b> Indicates that a high temperature error has occurred in the fuser. This error is saved in the controller board by an electrical charge in capacitor C259.	<b>Action:</b> <ol style="list-style-type: none"><li>1 Turn the printer off and on to reset the printer.</li><li>2 Turn the printer off and unplug it. Place a flat blade of a screwdriver between the two wires of C259 to short out the capacitor and clear the memory.</li><li>3 Replace the fuser kit.</li><li>4 Replace the power supply.</li><li>5 Replace the controller board.</li></ol>

---

**Table 39. Numbered printer messages (continued)**

---

<b>50.4 FUSER ERROR CYCLE POWER</b>	<b>Event log message:</b> 50.00.04
<b>Description:</b> Indicates that a fuser drive or power unit error has occurred in the fuser.	<b>Action:</b> <ol style="list-style-type: none"><li>1 Turn the printer off and on to reset the printer.</li><li>2 Verify the fuser is completely seated inside the printer.</li><li>3 Replace the power supply.</li><li>4 Replace the controller board.</li></ol>
<hr/>	
<b>50.6 FUSER ERROR CYCLE POWER</b>	<b>Event log message:</b> 50.00.06
<b>Description:</b> Indicates that a heater error has occurred in the fuser.	<b>Action:</b> <ol style="list-style-type: none"><li>1 Turn the printer off and on to reset the printer.</li><li>2 Verify the fuser is completely seated inside the printer.</li><li>3 Reconnect connector J222 on the controller board, connector J26 on the fuser, and connector J101 on the power supply.</li><li>4 Replace the fuser kit.</li><li>5 Replace the power supply.</li><li>6 Replace the controller board.</li></ol>
<hr/>	
<b>51 LASER ERROR CYCLE POWER</b>	<b>Event log message:</b> 51.00.01
<b>Description:</b> Indicates that a laser malfunction has occurred.	<b>Action:</b> <ol style="list-style-type: none"><li>1 Turn the printer off and on to reset the printer.</li><li>2 Reconnect connector J1001 on the laser driver PCA and connector J205 on the controller board.</li><li>3 Reconnect connector J2 on the beam detect PCA, relay connector J40, and connector J211 on the controller board.</li><li>4 Replace the laser/scanner unit.</li><li>5 Measure the voltage across connector J211-1 (+5 V) and J211-3 (GND) on the controller board after the printer is turned on. If the voltage is not 5 V, replace the laser/scanner unit.</li><li>6 Replace the controller board.</li></ol>

---

**Table 39. Numbered printer messages (continued)**

---

<b>52 SCANNER ERROR CYCLE POWER</b>	<b>Event log message:</b> 52.00.00
<b>Description:</b> Indicates that the scanner motor is not turning properly.	<b>Action:</b> <ol style="list-style-type: none"><li>1 Turn the printer off and on to reset the printer.</li><li>2 Reconnect connector J901 on the scanner motor PCA, relay connector J40, and connector J211 on the controller board.</li><li>3 Measure the voltage across connector J647-B11 (+24UH) and J647-4 (GND) on the main relay PCA after the printer is turned on. If the voltage is not 24 V, replace the power supply.</li><li>4 Measure the voltage across connector J211-7 (SCND) and J211-6 (GND) on the controller board after the printer is turned on. If the voltage changes from 0 V to 17 V or more, replace the laser/scanner unit.</li><li>5 Replace the laser/scanner unit.</li><li>6 Replace the controller board.</li></ol>

---

**Table 39. Numbered printer messages (continued)**

---

<b>53.&lt;x&gt;&lt;y&gt;.&lt;zz&gt; ERROR DIMM SLOT &lt;n&gt;</b>	<b>Event log message:</b> 53.<x><y>.<zz>
<b>Description:</b> Indicates that a memory error occurred during the configuration and validation of DIMM memory.	<b>Action:</b>
<b>&lt;x&gt; = Hardware type:</b> 0 = ROM 1 = RAM 2 = Font DIMM	<b>1</b> Verify that the DIMM board is installed correctly and the DIMMs are configured correctly. DRAM DIMMs must be installed in synchronous pairs in adjacent slots, with the same size and speed in both slots. Only SDRAM is supported.
<b>&lt;y&gt; = Hardware device:</b> 0 = Onboard ROM/RAM 1 = DIMM slot 1 2 = DIMM slot 2 3 = DIMM slot 3 4 = DIMM slot 4 5 = DIMM slot 5 6 = DIMM slot 6 7 = DIMM slot 7 8 = DIMM slot 8	<b>2</b> Turn the printer off and on to reset the printer.
<b>&lt;zz&gt; = Error:</b> 00 = Unsupported memory 01 = Unrecognized memory 02 = Unsupported memory size 03 = Failed RAM test 04 = Exceeded maximum RAM size 05 = Exceeded maximum ROM size 06 = Invalid DIMM speed, check DRAM 07 = DIMM is reporting incorrect checksums 10 = DIMM address 11 = PDC XROM out of bounds 12 = Could not make temporary mapping 13 = Invalid RAM type 14 = DIMM not paired properly 15 = Bad firmware upgrade DIMM checksum 16 = More than one set of firmware upgrade DIMMs 17 = Not enough DRAM to run	<b>3</b> Remove and replace the DIMM that caused the error.
<b>&lt;n&gt; = EIO slot number:</b> 1 = Bottom EIO slot 2 = Top EIO slot	For more information about installing DIMMs, see page 93.

---

**Table 39. Numbered printer messages (continued)**

<b>54.1 TEMPERATURE SENSOR ERROR CYCLE POWER</b>	<b>Event log message:</b> 54.00.01
<b>Description:</b> Indicates that the temperature/humidity sensor in the printer has malfunctioned. The temperature/humidity sensor is located below tray 2.	<b>Action:</b> <ol style="list-style-type: none"><li>1 Reconnect connector J801 and relay connector J55 on the temperature/humidity sensor, and connector J206 on the controller board.</li><li>2 Replace the cassette crossmember assembly which includes the temperature/humidity sensor.</li><li>3 Replace the controller board.</li></ol>
<b>54.2 CAROUSEL ERROR CYCLE POWER</b>	<b>Event log message:</b> 54.00.02
<b>Description:</b> Indicates that the color toner carousel is not working correctly. This could be caused by an obstruction in the carousel path, such as a loose shutter or disengaged toner cartridge.	<b>Action:</b> <ol style="list-style-type: none"><li>1 Turn the printer off and on to reset the printer.</li><li>2 Open the carousel door and waste toner tray. Look for an obstruction, such as a toner cartridge shutter catching on the waste toner tray. Verify the toner lock lever is fully locked. If the message does not clear after closing the doors, turn the printer off and on to reset the printer.</li><li>3 Clean the carousel position sensor (PS3) with compressed air. If the problem persists, replace the sensor.</li><li>4 Reconnect connector J701 on carousel motor PCA; connectors J641, J642, J644, and J648 on the main relay PCA; connector J672 on the subrelay PCA; and connector J102 on the power supply.</li><li>5 Check operation of the carousel stopper arm. Replace the carousel stopper solenoid.</li><li>6 Check electrical continuity between connector J641-1 (+24 VB) and J642-3 (PMP) on the main relay PCA when the door switch (SW641) is turned on. If there is no electrical continuity, replace the main relay PCA.</li><li>7 Check electrical continuity between connector J644-1 (PBK) and J644-2 (PMP) on the main relay PCA when the door switch (SW644) is turned on. If there is no electrical continuity, replace the black toner cartridge on/off switch.</li></ol>

**Table 39. Numbered printer messages (continued)**

**(54.2 CAROUSEL ERROR  
CYCLE POWER, continued)**

- 8 Check electrical continuity between connector J642-1 (PYMC) and J642-2 (PBK) on the subrelay PCA when the door switch (SW673) is turned on. If there is no electrical continuity, replace the toner cartridge cover switch in the subrelay PCA.
- 9 Check electrical continuity between connector J642-1 (PYMC) and J648-1 (+24 VAR) on the main relay PCA when the door switch (SW642) is turned on. If there is no electrical continuity, replace the main relay PCA.
- 10 Measure the voltage across connector J648-1 (+24 VAR) and J648-3 (GND) on the main relay PCA after the printer is turned on. If the voltage is not 24 V, replace the main relay PCA.
- 11 Reconnect connectors J704 and J706 on the carousel motor PCA, and connector J220 on the controller board.
- 12 Reconnect connector J43 on the carousel position sensor, relay connector J42 and connector J207 on the controller board.
- 13 Measure the voltage across connector J220-A6 (RLSROT) and J220-B5 (GND) on the controller board after the printer is turned on. If the voltage changes to about 3.5 V from 0 V, replace the carousel motor PCA.
- 14 Replace the carousel motor (M1).
- 15 Replace the controller board.

---

**54.3 DENSITY SENSOR ERROR  
CYCLE POWER**

**Event log message:** 54.00.03

**Description:**

Indicates a density sensor error, or the printer is not receiving data back from the density sensor.

**Action:**

- 1 Turn the printer off and on to reset the printer.
- 2 Clean the density sensor (see page 100).
- 3 Reconnect connector J1101 on the density sensor PCA, intermediate connectors J75 and J46, and connector J206 on the controller board.
- 4 Replace the density sensor.

---

**54.4 WASTE TONER  
SENSOR ERROR  
CYCLE POWER**

**Event log message:** 54.00.04

**Description:**

The waste toner sensor has failed. Printing cannot continue.

**Action:**

- 1 Replace the waste toner sensor assembly.
  - 2 Replace the imaging drum.
-

**Table 39. Numbered printer messages (continued)**

<b>55 PRINTER ERROR CYCLE POWER</b>	<b>Event log message:</b> 55.00.01
<b>Description:</b> Indicates a printer command error. The commands cannot be exchanged between the printer and its controller.	<b>Action:</b> <ol style="list-style-type: none"><li>1 Turn the printer off and on to reset the printer.</li><li>2 Verify the controller board is fully seated.</li></ol>
<b>56.1 ERROR CYCLE POWER</b>	<b>Event log message:</b> 56.01.01
<b>Description:</b> Indicates an input feed error (such as requesting to feed transparencies through the duplexer), or the input tray is not installed.	<b>Action:</b> <ol style="list-style-type: none"><li>1 If the input tray you are trying to print from is not installed, install the input tray.</li><li>2 Turn the printer off and on to reset the printer.</li></ol>
<b>56.2 ERROR CYCLE POWER</b>	<b>Event log message:</b> 56.00.02
<b>Description:</b> Indicates an illegal output error. For example, the multi-bin mailbox is not installed and it was selected as the output destination, or there are transparencies in the duplexer.	<b>Action:</b> <ol style="list-style-type: none"><li>1 Open the printer and remove media from the paper path.</li><li>2 Verify that the media type is set in the printer control panel.</li><li>3 Turn the printer off and on to reset the printer.</li></ol>

**Table 39. Numbered printer messages (continued)**

---

<b>57.1 FAN FAILURE</b>	<b>Event log message:</b> 57.00.01
<b>Description:</b> One of the cooling fans failed or is obstructed.	<b>Action:</b>
1 = Fan 1 (FM 1)	<b>Caution: Turn the printer off and do not operate the printer in this condition or it can be seriously damaged.</b>
	<ol style="list-style-type: none"><li>1 Turn the printer off and on to reset it.</li><li>2 Reconnect connectors J702 and J706 on the carousel motor PCA, and connector J220 on the controller board.</li><li>3 Reconnect connector J701 on the carousel motor PCA, connectors J648 and J641 on the main relay PCA, and connector J102 on the DC power supply.</li><li>4 Measure the voltage across J702-3 (FAN1ON) and J701-2 (GND) on the carousel motor PCA after the printer is turned on. If the voltage changes from 0 V to 24 V, replace fan 1.</li><li>5 Measure the voltage across connector J701-1 (+24 VB) and J701-2 (GND) on the carousel motor PCA after the printer is turned on. If the voltage is about 24 V, replace the carousel motor.</li><li>6 Measure the voltage across connector J641-1 (+24 VB) and J641-4 (GND) on the main relay PCA after the printer is turned on. If the voltage is not 24 V, replace the main relay PCA.</li><li>7 Check the AC power supply.</li><li>8 If the problem is not rectified after the printer is turned off and on again, find the cause of activation of the overcurrent/overvoltage detection circuit in the power supply. Wait for more than two minutes before turning the power back on.</li><li>9 Replace the power supply.</li></ol>

---



**Table 39. Numbered printer messages (continued)**

---

<b>57.2 FAN FAILURE</b>	<b>Event log message:</b> 57.00.02
<b>Description:</b> One of the cooling fans failed or is obstructed.  2 = Fan 2 (FM 2)	<b>Action:</b>  <b>Caution: Turn the printer off and do not operate the printer in this condition or it can be seriously damaged.</b>  <ol style="list-style-type: none"><li>1 Turn the printer off and on to reset it.</li><li>2 Reconnect connectors J703 and J706 on the carousel motor PCA and connector J220 on the controller board.</li><li>3 Reconnect connector J701 on the carousel motor PCA, connector J648 on the main relay PCA, and connector J102 on the DC power supply.</li><li>4 Measure the voltage across connector J703-3 (FAN2ON) and J703-1 (GND) on the carousel motor PCA after the printer is turned on. If the voltage changes from 0 V to 24 V, replace fan 2.</li><li>5 Measure the voltage across connector J701-1 (+24 VB) and J701-2 (GND) on the carousel motor PCA after the printer is turned on. If the voltage is about 24 V, replace the carousel motor.</li><li>6 Measure the voltage across connector J641-1 (+24 VB) and J641-4 (GND) on the main relay PCA after the printer is turned on. If the voltage is 24 V, replace the main relay PCA.</li><li>7 Check the AC power supply.</li><li>8 If the problem is not rectified after the printer is turned off and on again, find the cause of activation of the overcurrent/overvoltage detection circuit in the power supply. Wait for more than two minutes before turning the printer back on.</li><li>9 Replace the power supply.</li></ol>

---

**Table 39. Numbered printer messages (continued)**

<b>57.3 FAN FAILURE</b>	<b>Event log message:</b> 57.00.03
<b>Description:</b> One of the cooling fans failed.  3 = Fan 3 (FM 3)	<b>Action:</b>  <b>Caution: Turn the printer off and do not operate the printer in this condition or it can be seriously damaged.</b>  <ol style="list-style-type: none"><li>1 Turn the printer off and on to reset it.</li><li>2 Reconnect connectors J645 and J647 on the main relay PCA, J18 and J74 relay connectors, and connector J227 on the controller board.</li><li>3 Reconnect connector J641 on the main relay PCA, and connector J102 on the power supply.</li><li>4 Measure the voltage across J645-3 (FAN3ON) and J645-1 (GND) on the main relay PCA after the printer is turned on. If the voltage changes from 0 V to 24 V, replace fan 3.</li><li>5 Measure the voltage across connector J641-1 (+24 VB) and J641-4 (GND) on the main relay PCA after the printer is turned on. If the voltage is not 24 V, replace the main relay PCA.</li><li>6 Measure the voltage across connector J641-1 (-24 VB) and J641-4 (GND) on the main relay PCA after the printer is turned on. If the voltage is not 24 V, replace the main relay PCA.</li><li>7 Check the AC power supply.</li><li>8 If the problem is not rectified after the printer is turned off and on again, find the cause of activation of the overcurrent/overvoltage detection circuit in the power supply. Wait for more than two minutes before turning the printer back on.</li><li>9 Replace the controller board.</li></ol>
<b>58.1 ERROR CYCLE POWER</b>	<b>Event log message:</b> 58.00.01
<b>Description:</b> Indicates that the paper diverter inside the right upper door is out of position, causing an error feeding media from tray 1.	<b>Action:</b>  <ol style="list-style-type: none"><li>1 Open the right upper door and check for a media jam or misfed media.</li><li>2 Turn the printer off and on to reset the printer.</li></ol>

**Table 39. Numbered printer messages (continued)**

<p><b>59.&lt;x&gt; MOTOR ERROR CYCLE POWER</b></p> <p><b>Description:</b> Indicates that the main motor (M4) is not working properly.</p> <p><b>&lt;x&gt; = Description:</b> 0 = General error 1 = Startup error 2 = Rotation error</p>	<p><b>Event log message:</b> 59.00.0&lt;x&gt;</p> <p><b>Action:</b></p> <ol style="list-style-type: none"> <li>1 Turn the printer off and on to reset the printer.</li> <li>2 Reconnect connector J219 and relay connector J1 on the controller board.</li> <li>3 Replace the main motor (M4).</li> <li>4 Reconnect connectors J641 to J643 and J647 on the main relay PCA, connectors J671 and J673 on the subrelay PCA, connector J102 on the power supply, and connector J227 on the controller board.</li> <li>5 Check electrical continuity between connector J641-1 (+24 VB) and J642-3 (PMP) on the main relay PCA when the door switch (SW641) is turned on. If there is no electrical continuity, replace the main relay PCA.</li> <li>6 Check electrical continuity between connector J671-2 (PMP) and J671-2 (PFUPR) on the subrelay PCA when the door switch (SW671) is turned on. If there is no electrical continuity, replace the subrelay PCA.</li> <li>7 Measure the voltage across connector J647-B11 (+24 UH) and J647-4 (GND) on the main relay PCA after the printer is turned on. If the voltage is not 24 V, replace the main relay PCA.</li> <li>8 Replace the controller board.</li> </ol>
<p><b>62.&lt;x&gt; SERVICE CYCLE POWER</b></p> <p><b>Description:</b> Indicates that a problem exists with the internal memory.</p> <p><b>&lt;x&gt; = Description:</b> 0 = Internal ROM or RAM 1-8 = DIMM slots 1-8</p>	<p><b>Event log message:</b> 62.00.0&lt;x&gt;</p> <p><b>Action:</b></p> <ol style="list-style-type: none"> <li>1 Turn the printer off and on to reset the printer.</li> <li>2 Perform DRAM DIMM test from the formatter diagnostics in the Service Menu.</li> <li>3 If the problem persists, replace the bad DIMM.</li> </ol>
<p><b>63 SERVICE CYCLE POWER</b></p> <p><b>Description:</b> Indicates that the internal RAM memory test failed.</p>	<p><b>Event log message:</b> 63.00.00</p> <p><b>Action:</b></p> <ol style="list-style-type: none"> <li>1 Turn the printer off and on to reset the printer.</li> <li>2 Perform DRAM DIMM test from the formatter diagnostics in the Service Menu.</li> <li>3 If the problem persists, replace the bad DIMM.</li> </ol>

**Table 39. Numbered printer messages (continued)**

<p><b>64 PRINTER ERROR CYCLE POWER</b></p> <p><b>Description:</b> Indicates a scan buffer error.</p>	<p><b>Event log message:</b> 64.00.00</p> <p><b>Action:</b> Turn the printer off and on to reset the printer.</p>
<p><b>65 PRINTER ERROR CYCLE POWER</b></p> <p><b>Description:</b> Indicates a DRAM controller error.</p>	<p><b>Event log message:</b> 65.00.00</p> <p><b>Action:</b></p> <ol style="list-style-type: none"> <li>1 Turn the printer off and on to reset the printer.</li> <li>2 Perform DRAM DIMM test from the formatter diagnostics in the Service Menu.</li> <li>3 If the problem persists, replace the bad DIMM.</li> </ol>
<p><b>66.&lt;x&gt;0.&lt;yy&gt; C-LINK COMM ERROR CHECK CABLES AND CYCLE POWER</b></p> <p><b>Description:</b> Indicates a communication error between the 2,000-sheet input unit or the multi-bin mailbox and the printer.</p> <p>&lt;x&gt; = Device number in the link &lt;yy&gt; = Error code from the optional device</p>	<p><b>Event log message:</b> None</p> <p><b>Action:</b></p> <ol style="list-style-type: none"> <li>1 Verify that the C-link and power cables are connected.</li> <li>2 Turn the printer off and on to reset the printer.</li> </ol>
<p><b>66.11.01 INPUT DEVICE FAILURE CHECK CABLES AND CYCLE POWER</b></p> <p><b>Description:</b> Indicates a 2,000-sheet input unit lifting motor error.</p>	<p><b>Event log message:</b> 66.11.01</p> <p><b>Action:</b></p> <ol style="list-style-type: none"> <li>1 Verify that the c-link and power cables are connected.</li> <li>2 Turn the printer off and on to reset the printer.</li> <li>3 Verify that there are no objects or paper stored in the left side of the tray.</li> <li>4 Verify that the lifting plate moves freely by hand.</li> <li>5 Verify that the paper size plates are installed correctly, and that they are not bent.</li> <li>6 Replace the paper deck drive assembly bushing.</li> <li>7 Replace the paper deck drive assembly.</li> <li>8 Replace the paper tray (tray 4) for the 2,000-sheet input unit.</li> </ol>

**Table 39. Numbered printer messages (continued)**

---

<b>66.11.02 INPUT DEVICE FAILURE CHECK CABLES AND CYCLE POWER</b>	<b>Event log message:</b> 66.11.02
<b>Description:</b> Indicates a 2,000-sheet input unit feed motor error.	<b>Action:</b> <ol style="list-style-type: none"><li>1 Verify that the c-link and power cables are connected.</li><li>2 Turn the printer off and on to reset the printer.</li><li>3 Verify that there are no objects in the left side of the tray.</li><li>4 Verify that the paper tray raised sensor (PS34) is working properly (perform a sensor test).</li><li>5 Check for proper installation of the pick-up roller.</li><li>6 Check the pick-up assembly and the paper deck drive assembly cabling.</li><li>7 Replace the pick-up assembly.</li><li>8 Replace the paper deck drive assembly.</li></ol>
<b>66.11.03 INPUT DEVICE FAILURE CHECK CABLES AND CYCLE POWER</b>	<b>Event log message:</b> 66.11.03
<b>Description:</b> Indicates a 2,000-sheet input unit lifting and feed motor error.	<b>Action:</b> <ol style="list-style-type: none"><li>1 Verify that the c-link and power cables are connected.</li><li>2 Turn the printer off and on to reset the printer.</li><li>3 Verify that there are no objects in the left side of the tray.</li><li>4 Verify that the lifting plate moves freely by hand.</li><li>5 Verify that the paper size plates are installed correctly, and that they are not bent.</li><li>6 Replace the paper deck drive assembly bushing.</li><li>7 Replace the paper deck drive assembly.</li><li>8 Check that the paper tray raised sensor (PS34) is working properly (perform a sensor test).</li><li>9 Check for proper installation of the pick-up roller.</li><li>10 Check pick-up assembly cabling.</li><li>11 Replace the pick-up assembly.</li></ol>

---

**Table 39. Numbered printer messages (continued)**

<p><b>66.22.08 OUTPUT DEVICE FAILURE CHECK CABLES AND CYCLE POWER</b></p>	<p><b>Event log message:</b> 66.22.08</p>
<p><b>Description:</b> Indicates a multi-bin mailbox flipper motor error.</p>	<p><b>Action:</b></p> <ol style="list-style-type: none"> <li>1 Verify that the c-link and power cables are connected.</li> <li>2 Turn the printer off and on to reset the printer.</li> <li>3 Check for jams in the flipper assembly area.</li> <li>4 Replace the flipper assembly.</li> <li>5 Replace the multi-bin mailbox controller board PCA.</li> </ol>
<p><b>66.22.09 OUTPUT DEVICE FAILURE CHECK CABLES AND CYCLE POWER</b></p>	<p><b>Event log message:</b> 66.22.09</p>
<p><b>Description:</b> Indicates a multi-bin mailbox external memory error.</p>	<p><b>Action:</b></p> <ol style="list-style-type: none"> <li>1 Verify that the c-link and power cables are connected.</li> <li>2 Turn the printer off and on to reset the printer.</li> <li>3 Replace the multi-bin mailbox controller board PCA.</li> </ol>
<p><b>66.22.&lt;xx&gt; OUTPUT DEVICE FAILURE CHECK CABLES AND CYCLE POWER</b></p>	<p><b>Event log message:</b> 66.22.&lt;xx&gt;</p>
<p><b>Description:</b> Indicates a multi-bin mailbox error.</p> <p>&lt;xx&gt; = Error code from the optional device</p>	<p><b>Action:</b></p> <ol style="list-style-type: none"> <li>1 Verify that the c-link and power cables are connected.</li> <li>2 Turn the printer off and on to reset the printer.</li> <li>3 Replace the C-link cables.</li> <li>4 Replace the multi-bin mailbox controller board PCA.</li> </ol>
<p><b>67.&lt;x&gt; ERROR POWER CYCLE</b></p>	<p><b>Event log message:</b> 67.00.0&lt;x&gt;</p>
<p><b>Description:</b> Indicates an electronic controller error.</p> <p><b>&lt;x&gt; = Description:</b> 1 = Controller board error 2 = Controller board IC malfunction 3 = Internal communication malfunction</p>	<p><b>Action:</b></p> <ol style="list-style-type: none"> <li>1 Turn the printer off and on to reset the printer.</li> <li>2 Replace the controller board.</li> </ol>

**Table 39. Numbered printer messages (continued)**

<b>68 NVRAM ERROR SETTINGS CHANGED</b>	<b>Event log message:</b> 68.00.00
<b>Description:</b> Indicates that a recoverable error has been detected in the NVRAM (nonvolatile random-access memory). Values for some NVRAM settings were found to be illegitimate in form and were set back to their default value.	<b>Action:</b> <ol style="list-style-type: none"><li>1 Verify the printer control panel settings. One or more fields have been reset to their factory defaults during the error recovery.</li><li>2 Perform a factory defaults reset (see page 78).</li><li>3 Perform a cold reset (see page 376).</li></ol>
<b>68 NVRAM FULL SETTINGS LOST</b>	<b>Event log message:</b> 68.00.01
<b>Description:</b> Indicates that the NVRAM is full, and the printer is unable to write new data to the NVRAM.	<b>Action:</b> Verify the printer control panel settings. One or more fields might have been reset to their factory defaults during error recovery. The next time the printer is turned off and on, NVRAM will be cleared and all factory defaults will be restored.
<b>79 SERVICE &lt;xxxx&gt; CYCLE POWER</b>	<b>Event log message:</b> 79.<xxxx>
<b>Description:</b> The firmware has detected a hardware failure within the formatter. This failure can be caused by defective EIO devices and communication ports  <b>&lt;xxxx&gt; Description</b> 01<xx> = IO ASIC register error 02<xx> = Video ASIC register error 03<xx> = IDE ASIC register error	<b>Action:</b> <ol style="list-style-type: none"><li>1 Turn the printer off. Disconnect all communication cables and EIO cards. Turn the printer back on.</li><li>2 Run extended formatter diagnostics from the Service Mode Menu to troubleshoot the failure.</li><li>3 If the problem persists without the communications connected, replace the formatter board.</li></ol>

**Table 40. Unnumbered printer messages**

<b>ACCESS DENIED</b>	<b>Event log message:</b> None
<b>Description:</b> A user has attempted to select a menu value while printer control panel locking is enabled.	<b>Action:</b> See the system administrator for access to the printer control panel. If it is necessary to override the password, perform a cold reset. See page 376 for information on performing a cold reset.
<b>CALIBRATING</b>	<b>Event log message:</b> None
<b>Description:</b> The printer is adjusting the print density (see page 148 for more information).	<b>Action:</b> No action is required.  <b>Note:</b> It might take five to six minutes for the printer to complete the calibration.
<b>CANCELING JOB</b>	<b>Event log message:</b> None
<b>Description:</b> The printer is canceling the current print job.	<b>Action:</b> No action is required.
<b>CHECK CONTROL PANEL SETTINGS</b>	<b>Event log message:</b> None
<b>Description:</b> Indicates that the page might not be printing because the control panel setting for media type and/or size does not match the media in the tray.	<b>Action:</b> See page 91 for information on configuring media type and size for each input tray.
<b>CHECK TRAY 1 PAPER GUIDES</b>	<b>Event log message:</b> None
<b>Description:</b> The width of the paper guides does not match the size of the media selected for the print job.	<b>Action:</b> Adjust the media width guides to the edge of the page. Ensure the media size selected for the print job is the same as the size of media loaded in tray 1.



**Table 40. Unnumbered printer messages (continued)**

---

<b>CLEAN DENSITY SENSOR CYCLE POWER</b>	<b>Event log message:</b> 54.00.0<x>
<b>Description:</b> The density sensor values are out of range or inconsistent. The density sensor might be dirty or the transfer drum might be damaged. A defective toner cartridge could cause this error as well.	<b>&lt;x&gt; = Description:</b> 5 = Sensor abnormality 6 = Out of range cyan 7 = Out of range magenta 8 = Out of range yellow 9 = Out of range black  <b>Action:</b> <ol style="list-style-type: none"><li>1 Verify the right upper door is closed all of the way.</li><li>2 Clean the density sensor.</li><li>3 Turn the printer off and on to reset the printer.</li><li>4 Clean the transfer drum. For information on cleaning the printer, see page 422.</li><li>5 If the problem persists in one color, replace the faulty toner cartridge.</li><li>6 Replace the density sensor.</li></ol>
<b>CLEAR DUPLEX JAM LOWER LEFT DOOR</b>	<b>Event log message:</b> 13.00.0<x>
<b>Description:</b> The printer senses a media jam in the duplexer.	<b>&lt;x&gt; = Description:</b> 7 = Two-sided turn around paper late jam 8 = Two-sided turn around paper stopped jam 9 = Two-sided path paper late jam  <b>Action:</b> <ol style="list-style-type: none"><li>1 Open the left lower cover, remove the duplexer, remove the jammed media, reinstall the duplexer, and close the left lower cover.</li><li>2 The fusing assembly and diverter assemblies can also cause duplex printing problems. Verify their operation.</li><li>3 Open the left lower cover and defeat the delivery cover interlock. Toggle the sensors at the paper exit and entrance. While running the sensor monitor test from the Service Mode Menu, verify sensors 8 and 9 on the printer control panel indicate 1 (on) when toggled. <b>Note:</b> This procedure will not work if the left lower cover interlock is not defeated.</li><li>4 Replace the duplexer.</li></ol>

---

**Table 40. Unnumbered printer messages (continued)**

<p><b>CLEAR FUSER JAM LOWER LEFT DOOR</b></p> <p><b>Description:</b> The printer senses a media jam in the fuser area. The printer expected a page to come through the fuser, but the paper has not toggled PS1903, or PS1903 has been toggled an extended amount of time.</p> <p>See table 42 on page 381 for an explanation of paper jam detection details.</p>	<p><b>Event log message:</b> 13.00.0&lt;x&gt;</p> <p><b>&lt;x&gt; = Description:</b> 3 = Fusing delivery paper delay jam 4 = Fusing delivery stationary jam</p> <p><b>Action:</b></p> <p><b>WARNING!</b> Do not touch the fuser; it could be very hot and could cause burns.</p> <ol style="list-style-type: none"><li>1 Open the left lower cover, remove the jammed media, and close the left lower cover.</li><li>2 On the left side of the fuser, check the fuser exit flag and the reflective absorptive sticker that the sensor (PS1903) uses.</li><li>3 Perform the sensor monitor test in the Service Mode Menu. Toggle PS1903 and check to make sure that sensor 2 on the printer control panel indicates 1 (on) when toggled.</li></ol>
<p><b>CLEAR INPUT DEVICE JAM</b></p> <p><b>Description:</b> There is a jam in the 2,000-sheet input tray.</p>	<p><b>Event log message:</b> 13.11.1&lt;x&gt;</p> <p><b>&lt;x&gt; Description:</b> 1 = Time-out at paper entry sensor (PS31) B = Time-out at paper exit sensor (PS32)</p> <p><b>Action:</b></p> <ol style="list-style-type: none"><li>1 Open the vertical transfer unit (VTU) and remove any media.</li><li>2 Verify that the paper entry sensor (PS31) moves freely.</li><li>3 Verify that the feed, separation, and the pickup rollers are properly seated.</li><li>4 If the problem persists, open the VTU and override the VTU closed sensor (PS35). Perform a paper path test feeding from the 2,000-sheet input unit, and verify that the feed rollers are advancing the paper. If rollers do not rotate, verify the connections at the pickup assembly and the controller PCA in the 2,000-sheet input unit.</li><li>5 If the rollers rotate and drop down but do not advance the paper, replace the feed and separation rollers using the maintenance kit.</li><li>6 If the rollers do not rotate or do not drop down, replace the pickup assembly.</li><li>7 If the problem persists, replace the VTU, which includes PS31.</li></ol>

**Table 40. Unnumbered printer messages (continued)**

**CLEAR INPUT  
DEVICE JAM (continued)**

---

**Event log message:** 13.11.2<x>

**<x> Description:**

1 = Page stays too long at paper entry sensor (PS31)

B = Page stays too long at paper exit sensor (PS32)

**Action:**

- 1 Open the vertical transfer unit (VTU) and remove any media.
- 2 Verify that the paper entry sensor (PS31) moves freely.
- 3 Verify that the feed, separation, and the pickup rollers are properly seated.
- 4 If the problem persists, open the VTU and override the VTU closed sensor (PS35). Perform a paper path test feeding from the 2,000-sheet input unit, and verify that the feed rollers are advancing the paper. If rollers do not rotate, verify the connections at the pickup assembly and the controller PCA in the 2,000-sheet input unit.
- 5 If the rollers rotate and drop down but do not advance the paper, replace the feed and separation rollers using the maintenance kit.
- 6 If the rollers do not rotate or do not drop down, replace the pickup assembly.
- 7 If the problem persists, replace the VTU, which includes PS31.

---

**Event log message:** 13.11.3<x>

**<x> Description:**

1 = At power on, paper entry sensor (PS31) in VTU is active

B = At power on, paper exit sensor (PS32) in VTU is active

**Action:**

- 1 Open the vertical transfer unit (VTU) and remove any media.
  - 2 Verify that PS31 and PS32 in the VTU move freely.
  - 3 If either PS31 or PS32 are damaged, replace the VTU.
-

**Table 40. Unnumbered printer messages (continued)**

<b>CLEAR INPUT JAM</b>	<b>Event log message:</b> None
<b>Description:</b> The printer senses a media jam in the transfer or registration area, in an input tray, or in the duplexer.	<b>Action:</b> <ol style="list-style-type: none"><li>1 Open the front door, press the white button on the lower (green) lever, and swing the lever to the right. Open the right upper door, remove the transfer drum, and remove the jammed media from under the metal paper guide. Reinstall the transfer drum, and close the right upper door. Swing the lower (green) lever to the left, and close the front door.</li><li>2 Open each input tray, remove any jammed media, and close the input tray.</li><li>3 Open the left lower cover, remove the duplexer, remove the jammed media, reinstall the duplexer, and close the left lower cover.</li><li>4 Check the entire paper path for paper.</li></ol>
<b>CLEAR MAILBOX JAM</b>	<b>Event log message:</b> 13.22.01, 13.22.02
<b>Description:</b> The printer senses a media jam in the multi-bin mailbox.	<b>Action:</b> <ol style="list-style-type: none"><li>1 Open the jam access door and remove any media.</li><li>2 Verify that the left (face-up) output bin full sensor (PSFaceFull) flag moves freely.</li><li>3 Verify that the flipper shaft is in place.</li><li>4 Replace the flipper assembly.</li><li>5 Replace the multi-bin mailbox controller board PCA.</li></ol>
	<b>Event log message:</b> 13.22.03
	<b>Action:</b> <ol style="list-style-type: none"><li>1 Check for a jam at the double-belt system and delivery head assembly.</li><li>2 Ensure free movement of the double belt (both belts).</li><li>3 Ensure parallel position of the double belt system.</li><li>4 Verify that the metallic tape is in place and in good condition.</li><li>5 Replace the transport belt motor (M5).</li><li>6 Replace the multi-bin mailbox controller board PCA.</li><li>7 Replace the delivery head assembly.</li></ol>

**Table 40. Unnumbered printer messages (continued)**

<b>(CLEAR MAILBOX JAM, continued)</b>	<hr/> <b>Event log message:</b> 13.22.04 <b>Action:</b> <ol style="list-style-type: none"><li>1 Check for a jam in the delivery head assembly.</li><li>2 Ensure free movement in (PSExit1) sensor flags on the delivery head assembly.</li><li>3 Verify that the delivery roller fingers are over the ejector rollers on the delivery head assembly.</li><li>4 Replace the flat ribbon cable that connects to the delivery head assembly to the controller board PCA.</li><li>5 Replace the multi-bin mailbox controller board PCA.</li><li>6 Replace the delivery head assembly.</li></ol> <hr/>
	<b>Event log message:</b> 13.22.05 <b>Action:</b> <ol style="list-style-type: none"><li>1 Check for a jam in the delivery head assembly.</li><li>2 Ensure free movement in (PSExit2) sensor flags on the delivery head assembly.</li><li>3 Verify that the delivery roller fingers are over the ejector rollers on the delivery head assembly.</li><li>4 Replace the flat ribbon cable that connects to the delivery head assembly to the controller board PCA.</li><li>5 Replace the multi-bin mailbox controller board PCA.</li><li>6 Replace the delivery head assembly.</li></ol> <hr/>
<b>CLEAR OUTPUT JAM UPPER LEFT DOOR</b>  <b>Description:</b> <p>The printer senses a media jam in the top (face-down) output bin. This message might be caused by the paper not reaching PS11 or by paper toggling PS11 for an extended period of time.</p> <p>See table 42 on page 381 for an explanation of paper jam detection details.</p>	<b>Event log message:</b> 13.00.0<x>  <b>&lt;x&gt; = Description:</b> <p>5 = Delivery paper delay jam 6 = Delivery stationary jam</p> <b>Action:</b> <ol style="list-style-type: none"><li>1 Open the left upper door, remove the jammed media, and close the left upper door.</li><li>2 Verify that PS30, PS10, PS11, and PS3 sensors and the surrounding area are clean.</li><li>3 Perform sensor monitor test in the Service Mode Menu to verify all paper path sensors are functioning properly or to locate the paper jam.</li></ol> <hr/>

**Table 40. Unnumbered printer messages (continued)**

<b>CLEAR PAPER JAM</b>	<b>Event log message:</b> 13.00.00
<b>Description:</b> The printer senses a media jam. Since this is a generic media jam message, the media might be at any point in the paper path.	<b>Action:</b> <ol style="list-style-type: none"><li>1 Open and shut the front door of the printer to clear any media from the printer. Be sure to check the fuser area because media can get wrapped around the fuser and be difficult to find.</li><li>2 Check all areas of the printer for jammed media since the printer is unable to determine the location of the media jam.</li><li>3 Perform sensor monitor test in the Service Mode Menu to verify all paper path sensors are functioning properly or to locate the paper jam.</li></ol>
<b>CLEAR TRANSFER JAM</b>	<b>Event log message:</b> 13.00.10
<b>Description:</b> The printer senses a media jam in the transfer drum area when media has not reached PS5. In some cases the media might wrap around the transfer drum and become lodged near the imaging drum.  See table 42 on page 381 for an explanation of paper jam detection sensors.	<b>Action:</b> Open the right upper door, remove the transfer drum, remove the jammed media, reinstall the transfer drum, and close the right upper door.
<b>CLEAR TRAY 4 JAM</b>	<b>Event log message:</b> None
<b>Description:</b> The printer senses a media jam in tray 4.	<b>Action:</b> Open tray 4 and the vertical transfer unit (VTU), remove the jammed media, and close both.
<b>CLEAR UNEXPECTED PAPER SIZE JAM THEN LOAD TRAY 1</b> <b>&lt;type&gt; &lt;size&gt;</b>	<b>Event log message:</b> 13.00.11
<b>Description:</b> The printer senses a media jam in tray 1, or the media fed is longer than what was expected.  <type> = Media type specified in the printer driver or application <size> = Media size specified in the printer driver or application  The <type> and <size> can be the default media type and size if an automatic paper override has occurred or if <b>Go</b> was pressed during a mount request.	<b>Action:</b> <ol style="list-style-type: none"><li>1 Open the right upper door and remove the jammed media.</li><li>2 Load the media type and size indicated on the printer control panel.</li></ol>

**Table 40. Unnumbered printer messages (continued)**

<b>CLEARING PAPER FROM PRINTER</b>	<b>Event log message:</b> None
<b>Description:</b> The printer is attempting to remove unusable media (such as a misfed page or media damaged in a media jam).	<b>Action:</b> No action is required.
<b>CLOSE &lt;location&gt; DOOR</b>	<b>Event log message:</b> None
<b>Description:</b> The printer senses that one of the doors is not closed properly.  <location> = A printer door	<b>Action:</b> <ol style="list-style-type: none"><li>1 Close the door indicated in the message.</li><li>2 Check the function of the door interlocks (see page 370 for interlock locations).</li></ol>
<b>COLD RESET</b>	<b>Event log message:</b> None
<b>Description:</b> The printer has recognized the key sequence for performing a cold reset. The printer will reset to the factory default settings.  <b>Note:</b> Before performing a cold reset, print a configuration page as a reference for resetting the printer settings. See page 361 for information on printing a configuration page.	<b>Action:</b> No action is required. For more information on factory default settings, see the menu maps beginning on page 68.  See page 376 for more information on performing a cold reset.
<b>CONFIG LANGUAGE</b>	<b>Event log message:</b> None
<b>Description:</b> The printer has recognized the key sequence for selecting the display language.	<b>Action:</b> Wait for the display language options to appear and select the appropriate language. For more information on selecting the display language, see page 84.
<b>CONTINUOUS TEST PRESS CANCEL JOB</b>	<b>Event log message:</b> None
<b>Description:</b> A continuous configuration page is printing.	<b>Action:</b> Press <b>CANCEL JOB</b> to exit the configuration page printout mode. If the printer is in the process of printing when <b>CANCEL JOB</b> is pressed, the printer finishes printing the buffered pages before returning online.
<b>DATA RECIEVED PRESS GO KEY</b>	<b>Event log message:</b> None
<b>Description:</b> The printer has received and processed data. The printer is waiting for a formfeed.	<b>Action:</b> Press <b>GO</b> .

**Table 40. Unnumbered printer messages (continued)**

<b>DISK DEVICE FAILURE</b>	<b>Event log message:</b> 30.00.01
<b>Description:</b> The printer hard disk's internal self-test routine has been invoked to read minimum and maximum logical block addresses (with no retries) and has detected a failure. If access to the printer hard disk is not required, printer operation can continue.	<b>Action:</b> Replace the printer hard disk.
<b>DISK FILE OPERATION FAILED</b>	<b>Event log message:</b> None
<b>Description:</b> The printer has received an illogical PJI command (such as download to nonexistent directory).	<b>Action:</b> No action is required.
<b>DISK IS FULL</b>	<b>Event log message:</b> None
<b>Description:</b> The printer hard disk is full.	<b>Action:</b> <ol style="list-style-type: none"><li>1 From the host computer, delete data from the printer hard disk using the printer drivers or a disk management application.</li><li>2 To clear <i>all</i> data from the printer hard disk, reformat the printer hard disk from the printer control panel. To reformat the printer hard disk:<ol style="list-style-type: none"><li>a Press <b>MENU</b> until CONFIGURATION MENU appears on the display.</li><li>b Press <b>ITEM</b> until INITIALIZE DISK appears on the display.</li><li>c Press <b>SELECT</b> to reformat the printer hard disk.</li></ol></li></ol>
<b>DISK IS WRITE PROTECTED</b>	<b>Event log message:</b> None
<b>Description:</b> A user has attempted to save to the printer hard disk while the printer hard disk is write-protected.	<b>Action:</b> See the system administrator for access to the printer hard disk.
<b>DRUM ERROR REPLACE DRUM KIT</b>	<b>Event log message:</b> None
<b>Description:</b> The printer has detected an error in the imaging drum memory device. Printing can continue but will be stopped as soon as the waste toner signal is triggered. Printing behavior is determined by the TONER LOW control panel setting.  See table 16 on page 75 for information on the TONER LOW setting.	<b>Action:</b> <ol style="list-style-type: none"><li>1 Turn the printer off and on to reset the printer.</li><li>2 Reconnect connector J209, and relay connectors J47 and J48 on the controller board.</li><li>3 Replace the drum kit.</li></ol>



**Table 40. Unnumbered printer messages (continued)**

<b>DRUM LIFE LOW REPLACE DRUM KIT</b>	<b>Event log message:</b> None
<b>Description:</b> The imaging drum is almost past its specified life. Printing can continue; however, print quality might be degraded.	<b>Action:</b> Although printing can continue, the drum kit should be replaced for optimum printer operation.
<b>DRUM LIFE OUT REPLACE DRUM KIT</b>	<b>Event log message:</b> None
<b>Description:</b> The imaging drum is past its specified life or the waste toner cartridge in the imaging drum is full. Printing cannot continue until the drum kit has been replaced.	<b>Action:</b> <ol style="list-style-type: none"><li>1 Replace the drum kit.</li><li>2 Remove the drum cartridge from the printer, and clean the waste toner sensor window with a dry cloth.</li><li>3 Reconnect connector J221 on the controller board, and connectors J631 to J633 and relay connector J71 on the waste toner sensor.</li><li>4 Reconnect connector J209, and relay connectors J47 and J48 on the controller board.</li><li>5 Replace the drum cartridge.</li><li>6 Replace the waste toner sensor.</li></ol>
<b>DUPLEX ERROR CHECK DUPLEXER</b>	<b>Event log message:</b> 54.00.03
<b>Description:</b> The printer has detected an error in the duplexer.	<b>Action:</b> <ol style="list-style-type: none"><li>1 Open the left lower cover, press the green tab on the right side of the duplexer, and pull the duplexer out of the printer. Check for and remove any jammed media from the duplexer. Reinstall the duplexer.</li><li>2 Turn the printer off and on to reset the printer.</li><li>3 Replace the duplexer.</li></ol>
<b>EIO &lt;n&gt; INITIALIZING</b>	<b>Event log message:</b> 40.00.01
<b>Description:</b> An EIO accessory is initializing.	<b>Action:</b> No action is required.
<b>&lt;n&gt; = EIO slot number:</b> 1 = Bottom EIO slot 2 = Top EIO slot	

**Table 40. Unnumbered printer messages (continued)**

<b>EIO &lt;n&gt; NOT FUNCTIONAL</b>	<b>Event log message:</b> 8<n>.<xxx>  <xxx> = Failure code
<b>Description:</b> Indicates an EIO card error, but printing can continue. The configuration page will indicate that EIO <n> is not supported.	<b>Action:</b> <ol style="list-style-type: none"><li>1 Turn the printer off and on to reset the printer.</li><li>2 Replace the offending EIO accessory.</li></ol>
<b>&lt;n&gt; = EIO slot number:</b> 1 = Bottom EIO slot 2 = Top EIO slot	
<b>ENGINE TEST</b>	<b>Event log message:</b> None
<b>Description:</b> The printer is running an internal test to verify operation. When the printer is finished, the printer returns to the ready state but remains offline.	<b>Action:</b> Press <b>Go</b> to bring the printer online.
<b>FACE UP OUTPUT BIN FULL</b>	<b>Event log message:</b> None
<b>Description:</b> The top output bin on the multi-bin mailbox is full.	<b>Action:</b> <ol style="list-style-type: none"><li>1 Remove all media from the top output bin in the multi-bin mailbox to continue printing.</li><li>2 Check the functionality of the Bin Full flag.</li></ol>
<b>FUSER LIFE LOW REPLACE KIT</b>	<b>Event log message:</b> None
<b>Description:</b> The fuser and paper rollers are almost past their specified life. The fuser kit has approximately 1,000 pages until the end-of-life warning will appear.	<b>Action:</b> Although printing can continue, the fuser kit should be replaced for optimum printer operation.  Replace the fuser kit and reset the fuser counter by pressing <b>SELECT</b> before attempting to print (or use the <b>RESETS</b> menu on the printer control panel).
<b>FUSER LIFE OUT REPLACE KIT</b>	<b>Event log message:</b> None
<b>Description:</b> The fuser and paper rollers are past their specified life.  If <b>TONER LOW</b> is set to <b>CONTINUE</b> in the Configuration Menu, printing can continue with degraded print quality. Otherwise printing will be halted.	<b>Action:</b> Replace the fuser kit and reset the fuser counter by pressing <b>SELECT</b> before attempting to print (or use the <b>RESETS</b> menu on the printer control panel).  See table 16 on page 75 for information on the <b>TONER LOW</b> setting.

**Table 40. Unnumbered printer messages (continued)**

<b>INCORRECT FUSER LOWER LEFT DOOR</b>	<b>Event log message:</b> 50.00.05
<b>Description:</b> The printer has detected that an incompatible fuser (possibly the wrong voltage of fuser for the printer) has been installed.	<b>Action:</b> <ol style="list-style-type: none"><li>1 Remove the fuser and install the fuser specified for use with this printer. Printing cannot continue until the correct fuser is installed in the printer. For information on ordering a fuser kit, see page 445.</li><li>2 Reconnect connector J222 on the controller board and connector J26 on the fuser.</li><li>3 Replace the controller board.</li></ol>
<b>INPUT DEVICE PAPER PATH OPEN</b>	<b>Event log message:</b> None
<b>Description:</b> The vertical transfer unit (VTU) on the 2,000-sheet input unit is open.	<b>Action:</b> Close the VTU.
<b>INSTALL &lt;color&gt;</b>	<b>Event log message:</b> None
<b>Description:</b> The toner cartridge is either not installed, not correctly installed in the printer, or not being detected by the cartridge sensor.  <Color> = Cyan, magenta, yellow, or black	<b>Action:</b> <ol style="list-style-type: none"><li>1 Insert the cartridge or make sure the installed cartridge is correctly seated in the printer.  <b>Note:</b> The color toner carousel will not rotate unless the following conditions are met:<ul style="list-style-type: none"><li>• The blue toner lever is locked.</li><li>• The clear door is closed.</li><li>• The imaging drum is installed.</li><li>• The black toner cartridge is installed completely, including removing the orange seal from the black toner cartridge and swinging the upper (blue) lever to the left.</li><li>• The right upper door is closed.</li></ul></li><li>2 Turn the printer off and on to reset the printer.</li><li>3 If the cartridge is installed correctly, check that the sensor PS1901C is functioning properly.</li><li>4 Clean the sensor with a toner wipe.</li><li>5 Reconnect connector J221 on the controller board, and connector J621 and relay connector J70 on the remaining color toner sensor.</li></ol>
<b>Caution:</b> Use the blue button to rotate the carousel to prevent damage to the printer.	

**Table 40. Unnumbered printer messages (continued)**

**(INSTALL <color>, continued)**

- 6 Make sure that the black toner cartridge is installed.
  - Install the black toner cartridge if it is not installed.
  - If the black toner cartridge is already installed, turn the printer off, reinstall the black toner cartridge, and turn the printer on again.
- 7 Reconnect connectors J641 and J644 on the main relay PCA, and connector J102 on the power supply.
- 8 Reconnect connector J227 on the controller board, and connector J647 on the main relay PCA.
- 9 Check electrical continuity between connector J644-1 (PBK) and J644-2 (PMP) when the door switch (SW644) is turned on. If there is no electrical continuity, replace the black toner cartridge on/off switch.
- 10 Check the upper (blue) lever (black toner cartridge lever) on the printer. Move the lever to the left. Replace the lever if it is cracked.
- 11 Replace the black toner cartridge if it is deformed or damaged.
- 12 Replace the remaining color toner sensor.
- 13 Replace the controller board.

---

**INSTALL FUSER  
LOWER LEFT DOOR**

**Description:**

The printer has detected that the fuser is not installed.

**Event log message:** None

**Action:**

- 1 Install the fuser and verify that it is working correctly.
  - 2 Reconnect connector J26 on the fuser.
  - 3 Reconnect connector J222 on the controller board.
  - 4 Replace the controller board.
-

**Table 40. Unnumbered printer messages (continued)**

<b>INSTALL IMAGING DRUM OPEN FRONT DOOR</b>	<b>Event log message:</b> None
<b>Description:</b> The printer has detected that the imaging drum is not installed.	<b>Action:</b> <b>1</b> Install the imaging drum before attempting to print. If the condition persists, take the imaging drum out and reinstall it.
<b>Note:</b> All doors must be closed for the printer to detect the imaging drum.	<b>Note:</b> The imaging drum must be installed and the upper lever must be to the left in order for the carousel to rotate.
	<b>2</b> Turn the printer off and on to reset the printer.
	<b>3</b> Replace the drum cartridge.
	<b>4</b> Replace the drum cartridge if the drum cartridge on/off switch guide is deformed.
	<b>5</b> Make sure that the drum cartridge is installed.
	<ul style="list-style-type: none"><li>• Install the drum cartridge if it is not installed.</li><li>• If the drum cartridge is already installed, turn the printer off, reinstall the drum cartridge, and turn the printer on again.</li></ul>
	<b>6</b> Reconnect connectors J641 to J643 and J647 on the main relay PCA, connectors J671 and J673 on the subrelay PCA, connector J102 on the power supply, and connector J227 on the controller board.
	<b>7</b> Check electrical continuity between connector J641-1 (+24 VB) and J642-3 (PMP) on the main relay PCA when the door switch (SW641) is turned on. If there is no electrical continuity, replace the right cover switch on the main relay PCA.
	<b>8</b> Check electrical continuity between connector J671-2 (PMP) and J671-2 (PFUPR) on the subrelay PCA when the door switch (SW671) is turned on. If there is no electrical continuity, replace the delivery cover/front cover switches on the subrelay PCA.
	<b>9</b> Measure the voltage across connector J641-1 (+24 VB) and J641-A1 (GND) on the main relay PCA after the printer is turned on. If the voltage is not 24 V, replace the power supply.
	<b>10</b> Measure the voltage across connector J647-B11 (+24UH) and J647-4 (GND) on the main relay PCA after the printer is turned on. If the voltage is not 24 V, replace the main relay PCA.

**Table 40. Unnumbered printer messages (continued)**

<p><b>(INSTALL IMAGING DRUM OPEN FRONT DOOR, continued)</b></p>	<p>11 Check the drum cartridge on/off switch lever on the printer. Set the lever at the correct position if it is disconnected. Replace the lever if it is cracked.</p> <p>12 Reconnect connector J209, and relay connectors J47 and J48 on the controller board.</p> <p>13 Replace the controller board.</p>
<p><b>INSTALL TRANSFER DRUM OPEN RIGHT DOOR</b></p>	<p><b>Event log message:</b> None</p>
<p><b>Description:</b> The printer has detected that the transfer drum is not installed.</p> <p><b>Note:</b> All doors must be closed for the printer to detect the transfer drum. If the right upper cover interlock is defeated, this error will occur unless the density sensor is covered with paper.</p>	<p><b>Action:</b></p> <p>1 Install the transfer drum before attempting to print.</p> <p>2 Take the transfer drum out and reinstall it.</p> <p>3 Make sure that the transfer drum is installed.</p> <ul style="list-style-type: none"> <li>• If the transfer drum is not already installed, install the transfer drum.</li> <li>• If the transfer drum is already installed, turn the printer off, verify the transfer drum is in the correct position, and turn the printer on again.</li> </ul> <p>4 Reconnect connector J1101 on the density sensor PCA, intermediate connectors J75 and J46, and connector J206 on the controller board.</p> <p>5 Measure the voltage across connector J704-1 (+24 VAR) and GND on the density sensor PCA after the printer is turned on. If the voltage is not about 24 V, replace the density sensor PCA.</p> <p>6 Replace the controller board.</p>
<p><b>LANGUAGE = &lt;xxxx&gt;</b></p>	<p><b>Event log message:</b> None</p>
<p><b>Description:</b> Displayed during start up. The printer has recognized the key sequence for changing the control panel language.</p>	<p><b>Action:</b> No action is required. For more information on changing the printer control panel display language, see page 84.</p>
<p>&lt;xxxx&gt; = Printer control panel display language</p>	

**Table 40. Unnumbered printer messages (continued)**

<b>LEFT OUTPUT BIN FULL</b>	<b>Event log message:</b> None
<b>Description:</b> The left (face-up) output bin on the printer is full.	<b>Action:</b> Remove all media from the left (face-up) output bin of the printer to continue printing.
<b>Note:</b> This message appears only if the optional multi-bin mailbox is installed.	
<b>LOCK TONER LEVER</b>	<b>Event log message:</b> None
<b>Description:</b> The blue lever inside the clear door is not locked.	<b>Action:</b> <ol style="list-style-type: none"><li>1 Open the front door of the printer, open the clear door, and swing the blue toner lock lever on the carousel to the right.</li><li>2 Remove the toner cartridge, and then reinstall it, making sure the cartridge is all the way in the printer.</li><li>3 Swing the blue toner lock lever on the carousel to the left until it clicks, and then close the clear and front doors.</li></ol>
<b>MAILBOX COMM ERROR CHECK CABLES CYCLE POWER</b>	<b>Event log message:</b> None
<b>Description:</b> Communication with the multi-bin mailbox has been lost.	<b>Action:</b> <ol style="list-style-type: none"><li>1 Verify all cables are connected correctly.</li><li>2 Turn the printer off and on to reset the printer.</li></ol>
<b>MAILBOX &lt;x&gt; OUTPUT BIN FULL</b>	<b>Event log message:</b> None
<b>Description:</b> A mailbox in the multi-bin mailbox is full.  <x> = Mailbox 1 through 8	<b>Action:</b> Remove all media from the multi-bin mailbox to continue printing.
<b>MAILBOX NOT ATTACHED</b>	<b>Event log message:</b> None
<b>Description:</b> The multi-bin mailbox is not correctly attached to the printer. The printer will print to the top (face-down) output bin when in this state.	<b>Action:</b> Push the multi-bin mailbox up against printer.

**Table 40. Unnumbered printer messages (continued)**

<b>MANUALLY FEED</b> <b>&lt;type&gt; &lt;size&gt;</b>	<b>Event log message:</b> None
<b>Description:</b> The printer is requesting a sheet of media or envelope to be manually fed.  <type> = Media type specified in the printer driver or application <size> = Media size specified in the printer driver or application	<b>Action:</b> Load the requested media type and size into tray 1. If the proper media size is already loaded into tray 1, press <b>Go</b> to initiate printing.
<b>MEMORY SHORTAGE</b> <b>PAGE SIMPLIFIED</b>	<b>Event log message:</b> None
<b>Description:</b> The printer is compressing the print job so that all of the job will fit into the available printer memory. The print job's appearance might be altered by the compression of the data.	<b>Action:</b> <ol style="list-style-type: none"><li>1 If possible, simplify the print job by lowering the resolution of graphics.</li><li>2 Install more printer memory. For more information on printer memory options, see page 445.</li></ol>
<b>NO JOB TO CANCEL</b>	<b>Event log message:</b> None
<b>Description:</b> <b>CANCEL JOB</b> was pressed and there is no job to cancel.	<b>Action:</b> No action is required.
<b>NO JOBS PENDING</b>	<b>Event log message:</b> None
<b>Description:</b> While in the Proof and Print Menu, <b>ITEM</b> was pressed and there are no pending proof and print jobs.	<b>Action:</b> No action is required.
<b>OFFLINE</b>	<b>Event log message:</b> None
<b>Description:</b> The printer is offline.	<b>Action:</b> Press <b>Go</b> to bring the printer online.



**Table 40. Unnumbered printer messages (continued)**

<b>OUT OF MEMORY JOB CLEARED</b>	<b>Event log message:</b> None
<b>Description:</b> The printer personality for the current job could not be run in the available memory. The job was canceled, and no pages were printed.	<b>Action:</b> <ol style="list-style-type: none"><li>1 Reprint the job. If the message still appears, turn the printer off and on to reset the printer before sending the print job again.</li><li>2 Install more printer memory. For more information on printer memory options, see page 445.</li></ol>
<b>PCL MEMORY FULL STORED DATA LOST</b>	<b>Event log message:</b> None
<b>Description:</b> The resource save area for the printer personality is full. Fonts downloaded to the printer RAM might have been deleted.	<b>Action:</b> Turn the printer off and on to clear the printer RAM.
<b>PJL OPERATIONS FAILED</b>	<b>Event log message:</b> None
<b>Description:</b> The requested PJL operation could not be completed because the option is unavailable or the PJL data was corrupt.	<b>Action:</b> No action is required.
<b>PLEASE WAIT</b>	<b>Event log message:</b> None
<b>Description:</b> The printer is in the process of going offline or into the menus.	<b>Action:</b> No action is required.
<b>POWERSAVE ON</b>	<b>Event log message:</b> None
<b>Description:</b> The printer is in Power Save mode. Power Save settings can be changed on the printer control panel through the Configuration Menu (see page 75).	<b>Action:</b> Clear this message by pressing any key. <b>Note:</b> This message will also be cleared if a print job is sent to the printer or if an error condition is detected by the printer.

**Table 40. Unnumbered printer messages (continued)**

<p><b>PRESS SELECT IF FUSER IS NEW</b></p> <p><b>Description:</b> The printer has detected that a new fuser might have been installed.</p> <p><b>Note:</b> This message will also occur if the printer is turned off and on and the internal fuser count indicates the fuser is near the end of its life, or the fuser door is opened. The message displays for 10 seconds.</p>	<p><b>Event log message:</b> None</p> <p><b>Action:</b></p> <ol style="list-style-type: none"><li>1 If the fuser has been replaced, press <b>SELECT</b> to reset the internal counter. If the message clears before pressing <b>SELECT</b>, the value can be reset in the RESETS menu.</li><li>2 If the fuser has not been replaced, press <b>Go</b>.</li></ol>
<p><b>PRESS SELECT IF TRANSFER IS NEW</b></p> <p><b>Description:</b> The printer has detected that a new transfer drum might have been installed.</p> <p><b>Note:</b> This message will also occur if the printer is turned off and on and the internal transfer count indicates the transfer drum is near the end of its life, or the transfer door is opened. The message displays for 10 seconds.</p>	<p><b>Event log message:</b> None</p> <p><b>Action:</b></p> <ol style="list-style-type: none"><li>1 If the transfer drum has been replaced, press <b>SELECT</b> to reset the internal counter. If the message clears before pressing <b>SELECT</b>, the value can be reset in the RESETS menu.</li><li>2 If the transfer drum has not been replaced, press <b>Go</b>.</li></ol>
<p><b>PRESS SELECT TO INITIALIZE DISK</b></p> <p><b>Description:</b> The printer hard disk is new or has been formatted for another file system.</p>	<p><b>Event log message:</b> None</p> <p><b>Action:</b></p> <ol style="list-style-type: none"><li>1 Press <b>SELECT</b> to reformat the printer hard disk. All data currently on the printer hard disk will be lost.</li><li>2 If you don't want to initialize the printer hard disk, wait until the message clears (10 seconds) or press <b>Go</b> and the disk will not be initialized. This will render the disk non-functional, but the configuration page will show that the disk is installed.</li></ol>

**Table 40. Unnumbered printer messages (continued)**

<b>PRESS SELECT TO LOSE DISK DATA PRESS GO KEY TO CANCEL</b>	<b>Event log message:</b> None
<b>Description:</b> This is a request to confirm initialization of the printer hard disk (see PRESS SELECT TO INITIALIZE DISK above). Initialization will perform a high-level check of the disk and register the disk with the disk manager software.	<b>Action:</b> <ol style="list-style-type: none"><li>1 If you want to proceed with initialization, press <b>SELECT</b>.</li><li>2 If you don't want to initialize the printer hard disk, wait until the message clears (10 seconds) or press <b>Go</b> and the disk will not be initialized. This will render the disk non-functional, but the configuration page will show that the disk is installed.</li></ol>
<b>PRINTER LANGUAGE NOT AVAILABLE JOB CANCELED</b>	<b>Event log message:</b> None
<b>Description:</b> PjL encountered a request for a printer personality that does not exist in the printer. The job was canceled and no pages were printed.	<b>Action:</b> No action is required.
<b>PRINTING CONFIGURATION</b>	<b>Event log message:</b> None
<b>Description:</b> The printer is printing the configuration page. When the configuration page is printed, the printer returns to an online and ready state.	<b>Action:</b> No action is required.
<b>PRINTING DEMONSTRATION</b>	<b>Event log message:</b> None
<b>Description:</b> The printer is printing a demonstration page. When the demonstration page is printed, the printer returns to an online and ready state.	<b>Action:</b> No action is required.
<b>PRINTING EVENT LOG</b>	<b>Event log message:</b> None
<b>Description:</b> The printer is printing the event log. When the event log is printed, the printer returns to an online and ready state.	<b>Action:</b> No action is required.

**Table 40. Unnumbered printer messages (continued)**

<b>PRINTING FILE DIRECTORY</b>	<b>Event log message:</b> None
<b>Description:</b> The printer is printing the disk directory. When the file directory is printed, the printer returns to an online and ready state.	<b>Action:</b> No action is required.
<b>PRINTING FONT LIST</b>	<b>Event log message:</b> None
<b>Description:</b> The printer is printing the font list. When the font list is printed, the printer returns to an online and ready state.	<b>Action:</b> No action is required.
<b>PRINTING MENU MAP</b>	<b>Event log message:</b> None
<b>Description:</b> The printer is printing the menu map. When the menu map is printed, the printer returns to an online and ready state.	<b>Action:</b> No action is required.
<b>PROCESSING COPY &lt;x&gt; OF &lt;y&gt;</b>	<b>Event log message:</b> None
<b>Description:</b> The printer is processing a proof and print or mopy print job.	<b>Action:</b> No action is required.
<x> = Number of the copy in process <y> = Total number of copies	
<b>PROCESSING JOB</b>	<b>Event log message:</b> None
<b>Description:</b> The printer is actively processing a print job.	<b>Action:</b> No action is required.
<b>PROCESSING JOB FROM TRAY &lt;x&gt;</b>	<b>Event log message:</b> None
<b>Description:</b> The printer is actively processing a print job.	<b>Action:</b> No action is required.
<x> = Input tray (1, 2, 3, or 4).	

**Table 40. Unnumbered printer messages (continued)**

<b>PS MEMORY FULL STORED DATA LOST</b>	<b>Event log message:</b> None
<b>Description:</b> The resource save area for the printer personality is full. Fonts downloaded to the printer RAM might have been deleted.	<b>Action:</b> Turn the printer off and on to clear the printer RAM.
<b>READY</b>	<b>Event log message:</b> None
<b>Description:</b> The printer is online and ready for data. No status or printer attention messages are pending.	<b>Action:</b> No action is required.
<b>RESETTING ACTIVE IO</b>	<b>Event log message:</b> None
<b>Description:</b> The printer is resetting active I/O ports.	<b>Action:</b> No action is required.
<b>RESETTING ALL IO</b>	<b>Event log message:</b> None
<b>Description:</b> The printer is resetting all I/O ports.	<b>Action:</b> No action is required.
<b>RESTORING FACTORY SETTINGS</b>	<b>Event log message:</b> None
<b>Description:</b> The printer is resetting the printer's factory defaults. The printer is in the process of completing a cold reset. When the reset is completed, the printer returns to the ready state but remains offline.	<b>Action:</b> Reset the EIO type and configure the printer before bringing the printer online. For more information on factory defaults and configuring the printer control panel, see page 68.
<b>SEPARATOR OUTPUT BIN FULL</b>	<b>Event log message:</b> None
<b>Description:</b> The multi-bin mailbox output bins are full.	<b>Action:</b> Remove all media from the output bins on the multi-bin mailbox to continue printing.
<b>STACKER OUTPUT BIN FULL</b>	<b>Event log message:</b> None
<b>Description:</b> The multi-bin mailbox output bins are full.	<b>Action:</b> Remove all media from the output bins on the multi-bin mailbox to continue printing.

**Table 40. Unnumbered printer messages (continued)**

<b>TONER LOW REPLACE &lt;color&gt;</b>	<b>Event log message:</b> None
<b>Description:</b> The printer is almost out of the specified toner. The printer remains online and ready to print; however, the print quality might be degraded.  <color> = Cyan, magenta, yellow, or black	<b>Action:</b> Although printing can continue, the toner cartridge should be replaced for optimum printer operation.  <b>Note:</b> Do not shake the toner cartridge in attempts to extend the cartridge life.  For more information on configuring the printer response to this message, see the description of the TONER LOW setting on page 75.
<b>TONER OUT REPLACE &lt;color&gt;</b>	<b>Event log message:</b> None
<b>Description:</b> The printer is out of the specified toner and cannot continue.  <color> = Cyan, magenta, yellow, or black	<b>Action:</b> <ol style="list-style-type: none"><li>1 Replace the toner cartridge specified.</li><li>2 Reconnect connector J226 on the controller board and connector J5001 on high-voltage converter 1 PCA.</li><li>3 Check the contact for remaining toner detection on the black toner cartridge and the contact for remaining toner detection on the printer for deformation or damage.<ul style="list-style-type: none"><li>• Replace defective parts. (Replace the black toner cartridge if it is defective.)</li><li>• Check the contacts. If they are disconnected, return them to their correct positions.</li></ul></li><li>4 Replace the high-voltage converter 1 PCA.</li><li>5 Replace the controller board.</li></ol>
<b>TOO MANY FILE STORAGE DEVICES REMOVE EITHER DISK</b>	<b>Event log message:</b> None
<b>Description:</b> The printer can support only one physical printer hard disk and two have been detected. Printing will not be possible until one of the hard disks has been removed.	<b>Action:</b> Turn the printer off and remove the extra printer hard disk.  <b>Note:</b> The DN model comes with a factory installed internal hard disk on the formatter board.

**Table 40. Unnumbered printer messages (continued)**

<b>TOP OUTPUT BIN FULL</b>	<b>Event log message:</b> None
<b>Description:</b> The top (face-down) output bin of the printer is full.	<b>Action:</b> <ol style="list-style-type: none"><li>1 Remove all media from the top (face-down) output bin on the printer to continue printing.</li><li>2 Verify that PS30, PS10, PS11, and PS3 sensors and the surrounding area are clean.</li></ol>
<b>TRANSFER KIT LOW REPLACE KIT</b>	<b>Event log message:</b> None
<b>Description:</b> The transfer drum, transfer belt, cleaning roller, and charcoal filter are almost past their specified life. The transfer kit has approximately 750 color or 1,000 black-and-white images left until the printer will signal the end of the kit life.	<b>Action:</b> Although printing can continue, the transfer kit should be replaced for optimum printer operation.  Replace the transfer kit and reset the transfer counter by pressing <b>SELECT</b> before attempting to print (or use the RESETS menu on the printer control panel).
<b>TRANSFER KIT OUT REPLACE KIT</b>	<b>Event log message:</b> None
<b>Description:</b> The transfer drum, transfer belt, cleaning roller, and charcoal filter are past their specified life. If TONER LOW is set to continue, printing can continue with degraded print quality; otherwise printing will be halted.	<b>Action:</b> Replace the transfer kit and reset the transfer counter by pressing <b>SELECT</b> before attempting to print (or use the RESETS menu on the printer control panel).  For more information on configuring the printer response to this message, see the description of the TONER LOW setting on page 75.
<b>TRAY 1 CONTAINS UNKNOWN MEDIA</b>	<b>Event log message:</b> None
<b>Description:</b> Media was stacked in tray 1 for continuous manual feed printing, and the job has been completed. However, there is still media in the input tray. The printer considers the input tray not to be configured.	<b>Action:</b> Configure the media type for tray 1 or remove the remaining media.  For more information on configuring the media type, see page 90.

**Table 40. Unnumbered printer messages (continued)**

<b>TRAY 1 LOAD</b> <b>&lt;type&gt; &lt;size&gt;</b>	<b>Event log message:</b> None
<b>Description:</b> A user has requested a media size that is not currently installed in tray 1.  <type> = Last media type configured for the input tray <size> = Last media size configured for the input tray	<b>Action:</b> Load the media type and size specified on the printer control panel display. After tray 1 is loaded, the printer automatically brings itself online.  If the correct media type and size are loaded in tray 1 and the media does not feed into the printer, verify that the printer control panel settings for tray 1 (Cassette mode) match the media type and size requested.
<b>TRAY 1 SIZE = &lt;size&gt;</b>	<b>Event log message:</b> None
<b>Description:</b> This message is displayed when media is placed in tray 1 and the tray is configured for Cassette Mode.  <size> = Last media size configured for the input tray	<b>Action:</b> <ol style="list-style-type: none"><li>1 Press <b>– VALUE +</b> to view the choices.</li><li>2 Press <b>SELECT</b> when the choice you want is displayed.</li><li>3 Press <b>Go</b> to bring the printer online.</li></ol> If no key is pressed for 30 seconds after the media is detected in the input tray, the displayed size is automatically selected, the message is cleared, and printing begins.
<b>TRAY 4</b> <b>COMM ERROR</b> <b>CHECK CABLES</b> <b>CYCLE POWER</b>	<b>Event log message:</b> None
<b>Description:</b> Communication with the 2,000-sheet input unit has been lost.	<b>Action:</b> <ol style="list-style-type: none"><li>1 Verify all cables are connected correctly.</li><li>2 Turn the printer off and on to reset the printer.</li></ol>



**Table 40. Unnumbered printer messages (continued)**

<p><b>TRAY &lt;x&gt; EMPTY</b> <b>&lt;type&gt; &lt;size&gt;</b></p> <p><b>Description:</b> An input tray not currently selected has run out of media.</p> <p>&lt;x&gt; = Input tray number (2, 3, or 4) &lt;type&gt; = Last media type configured for the input tray &lt;size&gt; = Last media size configured for the input tray</p>	<p><b>Event log message:</b> None</p> <p><b>Action:</b></p> <ol style="list-style-type: none"> <li>1 Load the media type and size specified on the printer control panel display.</li> <li>2 Replace the upper/lower cassette lifter (remaining paper sensor lever) if it is damaged or deformed. Also, if the lifter is out of position, set it in its correct position.</li> <li>3 Reconnect connector J1201 on the pick-up PCA and connector J210 on the controller board.</li> <li>4 Replace the tray 2 and tray 3 remaining paper sensors 1 and 2.</li> <li>5 Replace the pick-up PCA.</li> <li>6 Replace the controller board.</li> </ol>
<p><b>TRAY &lt;x&gt; LIFTING</b></p> <p><b>Description:</b> The specified input tray is lifting the media into position for printing.</p> <p>&lt;x&gt; = Input tray number (2, 3, or 4)</p>	<p><b>Event log message:</b> None</p> <p><b>Action:</b> No action is required.</p>
<p><b>TRAY &lt;x&gt; LOAD</b> <b>&lt;type&gt; &lt;size&gt;</b> <b>CHECK CONTROL</b> <b>PANEL SETTING</b></p> <p><b>Description:</b> A user has requested a media size and type combination that is not currently installed or configured in the printer. This message is also generated when the current input tray runs out of media and no other auto-selectable input trays contain that size and type of media.</p> <p>&lt;x&gt; = Input tray number (1, 2, 3, or 4) &lt;type&gt; = Last media type configured for the input tray &lt;size&gt; = Last media size configured for the input tray</p>	<p><b>Event log message:</b> None</p> <p><b>Action:</b> Load the media type and size specified on the printer control panel display, and configure the media type in the printer control panel. After the requested input tray is loaded, the printer automatically goes online.</p> <p>Pressing <b>Go</b> causes the printer to attempt to print the page on the default type and size media. If the condition persists, check the input tray type and size configuration in the control panel.</p>

**Table 40. Unnumbered printer messages (continued)**

<b>TRAY &lt;x&gt; NOT FUNCTIONAL</b>	<b>Event log message:</b> None
<b>Description:</b> The installed tray is not supported by the printer.	<b>Action:</b> Press <b>Go</b> to continue printing.
<x> = Input tray number (2, 3, or 4)	
<b>TRAY &lt;x&gt; OPEN</b>	<b>Event log message:</b> None
<b>Description:</b> An input tray is open.	<b>Action:</b> Close the input tray before resuming printing.
<x> = Input tray number (2, 3, or 4)	
<b>TRAY &lt;x&gt; TYPE = &lt;type&gt;</b>	<b>Event log message:</b> None
<b>Description:</b> This message is displayed when media is placed in an input tray.	<b>Action:</b>
<x> = Input tray number (1, 2, 3, or 4) <type> = Last media type configured for the input tray	<ol style="list-style-type: none"><li>1 Press <b>- VALUE +</b> to view the choices.</li><li>2 Press <b>SELECT</b> when the choice you want is displayed.</li><li>3 Press <b>Go</b> to bring the printer online.</li></ol> <p>If no key is pressed for 30 seconds after the media is detected in the input tray, the displayed type is automatically selected, the message is cleared, and printing begins.</p>
<b>WARMING UP</b>	<b>Event log message:</b> None
<b>Description:</b> The fuser is warming up.	<b>Action:</b> No action is required.

## Aids to troubleshooting

This section describes various tools service personnel can use to diagnose hardware problems.

In addition to the tools described in this section, the service and support CD (which is included with your service manual) contains the user documentation. Use this additional information to supplement the information found in this manual.

### Configuration page

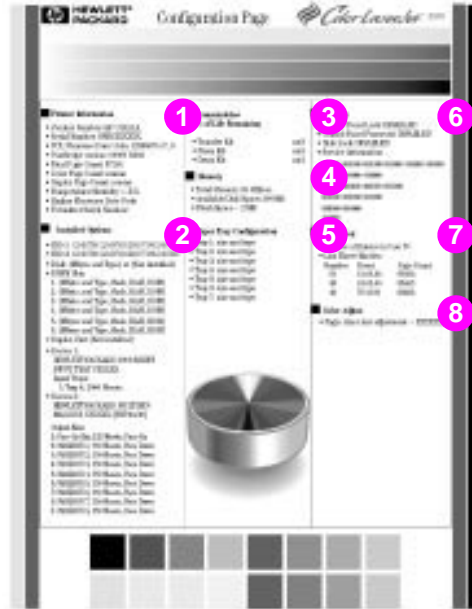
Print a configuration page to verify that the printer is set up correctly or to verify information about the printer's configuration. The page includes the following information:

- serial number
- formatter board number
- page counts (use if the controller board is being replaced as well)
- transfer kit count for percentage of life remaining
- fuser kit count for percentage of life remaining
- engine settings for verifying that the registration settings are accurate (the last two digits of the engine settings might vary from those found on the sticker)

### Printing a configuration page

- 1 Press **MENU** until INFORMATION MENU appears on the printer control panel display.
- 2 Press **ITEM** until PRINT CONFIG PAGE appears on the display.
- 3 Press **SELECT** to print the page.

## Interpreting a configuration page



**Figure 181.** Example of a configuration page

- 1 Printer Information** — Lists the following information:
  - printer product number
  - serial number
  - PCL firmware date code
  - PostScript version
  - total pages printed during the life of the printer
  - number of color pages printed during the life of the printer
  - number of black-and-white pages printed during the life of the printer
  - number of duplex pages printed during the life of the printer
- 2 Installed Options** — Shows whether options have been installed, such as the printer hard disk, DIMMs, duplexer, multi-bin mailbox, and optional input trays.
- 3 Consumables: % of Life Remaining** — Shows the percentage of the maximum rated life remaining for the transfer kit, fuser kit, and drum kit.

- 4 **Memory** — Shows the total memory installed in the printer (including the printer hard disk) and the settings that affect how the memory is used.
- 5 **Paper Tray Configuration** — Lists the types and sizes of media configured for each input tray.
- 6 **Security** — Shows whether the security features have been activated, such as the printer control panel lock, printer control panel password, and printer hard disk lock. There is also a service information code for service personnel.
- 7 **Event Log** — Lists the last three printer events, including media jams, service errors, and other printer actions.
- 8 **Color Adjust** — Lists the number of pages since the last manual color adjustment.

## Continuous configuration page

Continuous configuration pages can be printed to simulate full color printing in which two pages are developed on the transfer drum per rotation (two-page mode).

### Printing a continuous configuration page

- 1 Press **MENU** until INFORMATION MENU appears on the printer control panel display.
- 2 Press **ITEM** until PRINT CONTINUOUS CONFIG PAGES appears on the display.
- 3 Press **SELECT** to print the page.

---

**Note**

---

Press **CANCEL JOB** to stop printing. The printer will print all of the pages in the buffer before stopping.

## Demonstration page

Use this page to simulate printing a color image. If the image print quality is in question, a demonstration page should be printed to assure that the problem is not related to software, communications, or file quality.

### Printing a demonstration page

- 1 Press **MENU** until INFORMATION MENU appears on the printer control panel display.
- 2 Press **ITEM** until PRINT LASERJET DEMONSTRATION appears on the display.
- 3 Press **SELECT** to print the page.

## Event log

Detailed service information is noted in the event log. The following is a list of the types of messages logged in the event log:

- media jam errors
- disk failures
- EIO errors
- catastrophic errors

The last 50 errors are listed, with the most recent error first. Reoccurring events give indications of failing parts or problem areas within the printer. See the printer control panel message descriptions beginning on page 316 for more information on items found in the event log.

### Printing the event log

- 1 Press **MENU** until INFORMATION MENU appears on the control panel display.
- 2 Press **ITEM** until PRINT EVENT LOG appears on the display.
- 3 Press **SELECT** to print the page.

## Service mode engine diagnostics

Engine diagnostics can be used to perform mechanical tests on the print engine and its related components to help pinpoint components in the printer that need replacement or repair.

---

### WARNING!

Take care when you use engine diagnostics — some tests require door interlocks to be defeated, and defeating interlocks can expose potential hazards in the engine. High-voltage supplies and the laser are shut down whenever the printer is in diagnostic mode. However, any defeating of interlocks without entering the engine diagnostic mode results in potential exposure to the laser and high voltages.

---

### Entering the Service Mode Menu

- 1 From a READY state, press **MENU** until SERVICE MENU appears.
- 2 Press **ITEM –** (the left side of the key) and **VALUE –** simultaneously.

For a menu map of the Service Mode Menu, see page 80.

### Paper path test

The paper path test simulates a page moving through the paper path from input trays 1, 2, and 3 to the output bins. Removing some engine parts (such as the transfer drum) prevents paper from feeding completely. It is possible to select the input and output trays for the test by indicating in the Paper Path Menu which input tray and output bins should be accessed (by selecting ON or OFF). Multiple input trays can be selected, but only a single output can be selected. A page is fed from each input tray to the selected output. If a jam occurs during the test, the test should continue with the next input tray in the list.

---

### CAUTION

Jam detection is OFF in this mode and an unattended test might result in damage to the printer.

---

The pick-up rollers, feed rollers, registration roller, transfer belt press clutch (CL4), cleaning roller press cam and solenoid (SL1), fuser, transfer belt, and output feed roller can be exercised during the paper path test. For safety reasons, the fuser, high-voltage supplies, and scanner are all turned off during testing.

- 1 From the Service Mode Menu, press **MENU** until PAPER PATH appears.

- 2 Press **ITEM** until REPETITIONS appears.
- 3 Press **- VALUE +** to display the number of repetitions (1 to 10).
- 4 Press **SELECT** to choose the number of repetitions.
- 5 Press **ITEM** until the desired input source appears.
- 6 Press **- VALUE +** until ON or OFF appears on the display.
- 7 Press **SELECT**.

---

**Note**

You can select more than one input source for the test.

- 8 Press **ITEM** until OUTPUT= appears on the display.
- 9 Press **- VALUE +** until TOP OUTPUT BIN or LEFT OUTPUT BIN appears on the display.
- 10 Press **SELECT** to choose an output destination.
- 11 Press **ITEM** until EXECUTE TEST appears on the display.
- 12 Press **SELECT** to perform the paper path test.

---

**Notes**

To stop the paper path test, press **CANCEL JOB**.

The transfer drum can be removed with the right upper door open and the right cover interlock defeated (see figure 182 on page 370). However, media might not feed past the transfer area unless 11-by-17 inch or A3-sized media is used.

---



## Developer motor test

Visually and audibly inspect the cartridge motor (M3) and carousel motor (M1) as they rotate during this test. To view the printer components, run the test with the right upper door open and the transfer drum removed and the front cover and right upper door interlocks defeated (see figure 186 on page 372 and figure 182 on page 370). The engine runs this test for a fixed duration and then stops. Multiple repetitions of the test are allowed.

---

### Notes

For safety reasons, the fuser, high-voltage supplies, and scanner are all turned off during testing.

The carousel cannot turn with the imaging drum removed since the supply voltage to the carousel is cut off to avoid a pinch hazard.

---

- 1 From the Service Mode Menu, press **MENU** until DEVELOPER MOTOR appears.
- 2 Press **ITEM** until REPETITIONS appears.
- 3 Press **- VALUE +** to display the possible number of repetitions.
- 4 Press **SELECT** to choose the number of repetitions.
- 5 Press **ITEM** until EXECUTE TEST appears on the display.
- 6 Press **SELECT** to perform the developer motor test.

## Drum motor test

This test activates the drum motor (M2), imaging drum, transfer drum, and imaging drum waste paddle simultaneously. To view the printer components, run the test with the right upper door open, the transfer drum and imaging drum removed, and the right upper door interlock defeated (see figure 182 on page 370). The engine runs this test for a fixed duration and then stops.

---

### Note

---

For safety reasons, the fuser, high-voltage supplies, and scanner are all turned off during testing.

- 1 From the Service Mode Menu, press **MENU** until DRUM MOTOR appears.
- 2 Press **ITEM** until REPETITIONS appears.
- 3 Press **- VALUE +** to display the possible number of repetitions.
- 4 Press **SELECT** to choose the number of repetitions.
- 5 Press **ITEM** until EXECUTE TEST appears on the display.
- 6 Press **SELECT** to perform the drum motor test.

## Sensor monitor test

This test allows service personnel to activate and deactivate sensors in the printer to verify that the sensors are working properly.

---

### Note

---

For safety reasons, the fuser, high-voltage supplies, and scanner are all turned off during testing.

- 1 From the Service Mode Menu, press **MENU** until SENSOR MONITOR appears.
- 2 Press **ITEM** until EXECUTE TEST appears on the display.
- 3 Press **SELECT** to perform the sensor monitor test.
- 4 Determine whether each sensor is working by viewing the test results for each sensor on the printer control panel. A single character in the upper line of the display provides a label for each sensor bit. A 0 (off) or 1(on) is displayed for each sensor bit, indicating whether the sensor is activated or deactivated. See table 41 for an explanation of the test results.

**Table 41. Sensor monitor test**

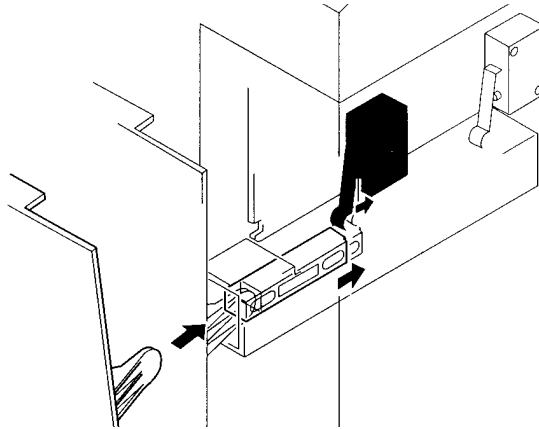
<b>Designator</b>	<b>Sensor name</b>
0	Registration roller paper sensor (PS1)
1	Pick-up unit paper sensor (PS17)
2	Separation sensor (PS5)
3	Fusing delivery sensor (PS1903)
4	Top (face-down) output bin delivery sensor (PS11)
5	Tray 1 paper sensor (PS1301)
6	Tray 2 sensor (PS1202)
7	Tray 3 sensor (PS1201)
8	Duplex paper sensor (PS24) Paper sensor in the duplexer in the output position
9	Reverse sensor (PS26) Paper sensor in the duplexer at the reversing position
A	Bit 0 of temperature/humidity sensor
B	Bit 1 of temperature/humidity sensor
	The ambient temperature and humidity sensor data are combined into 2 bits showing 4 states of temperature and humidity. 00 = Normal/normal 01 = High/high 10 = Normal/low 11 = Low/low

See figure 60 on page 172 for more information on these sensors.

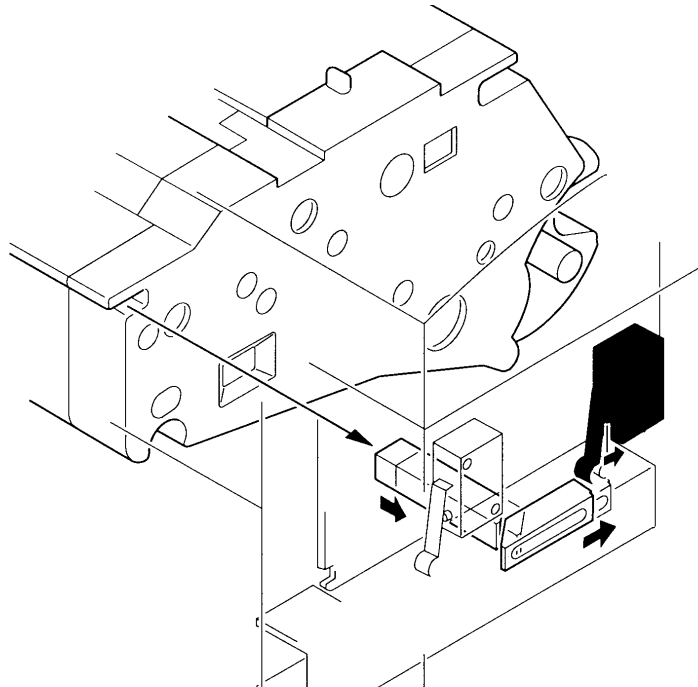
### **Exiting the service mode**

Exit the service mode by cycling through the menu until EXIT SERVICE MODE is reached, and press **SELECT**. It is not necessary to turn the printer off and on again unless you have accessed the formatter diagnostics.

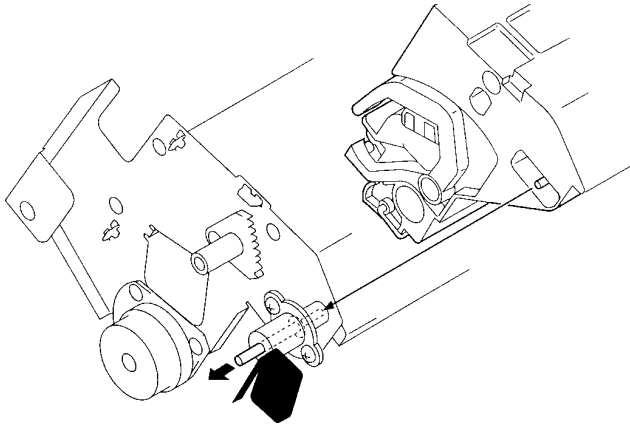
## Disabling interlocks



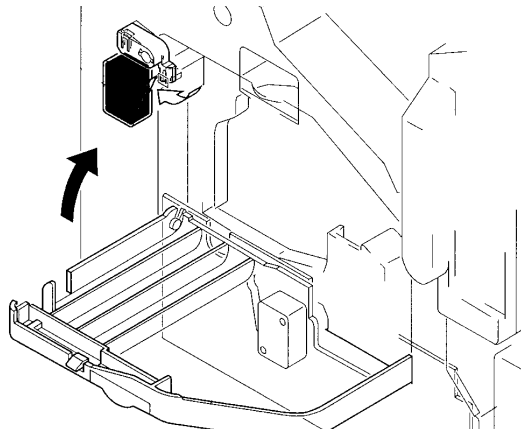
**Figure 182.** Right upper cover detection interlock



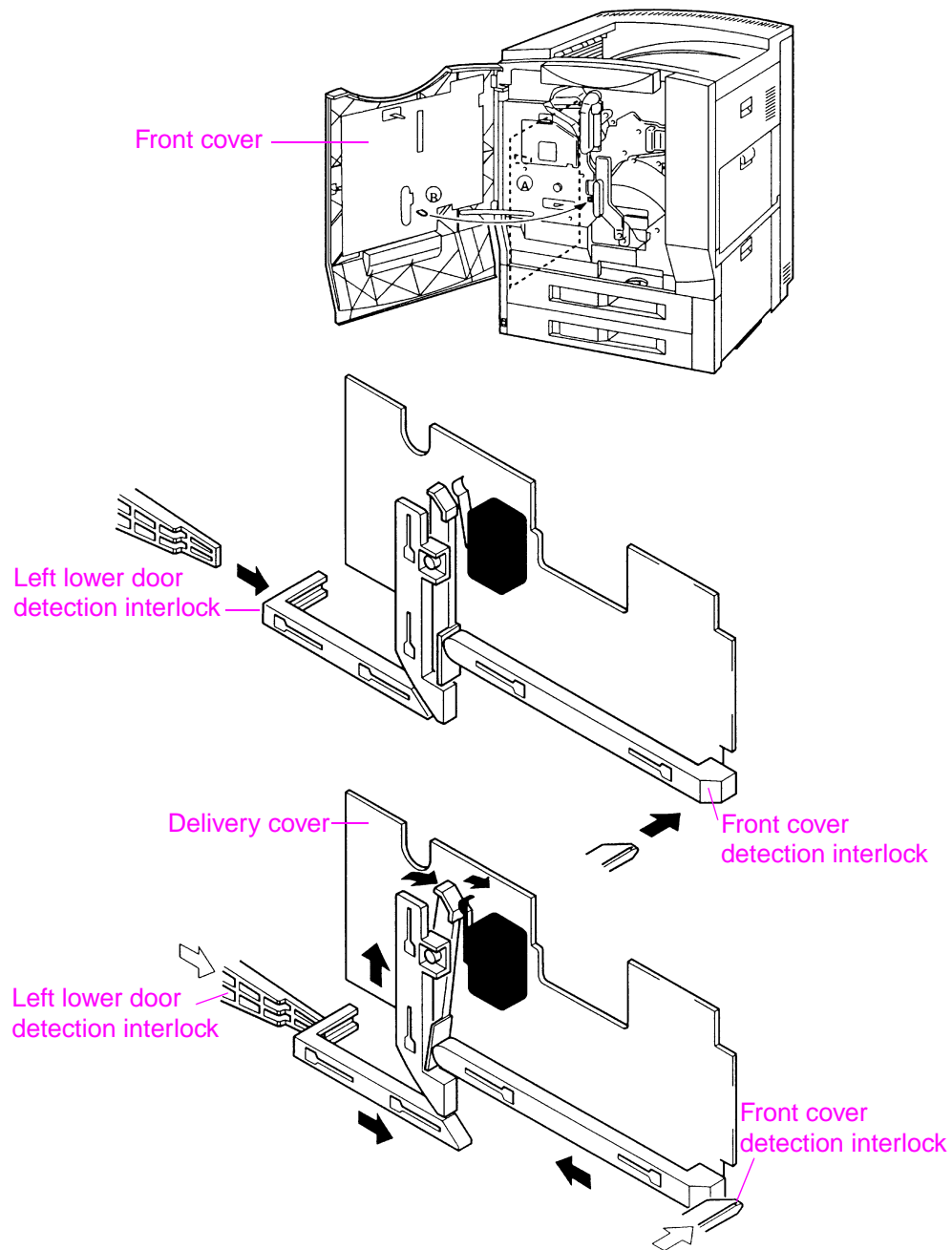
**Figure 183.** Drum cartridge detection interlock



**Figure 184.** Black toner cartridge detection interlock

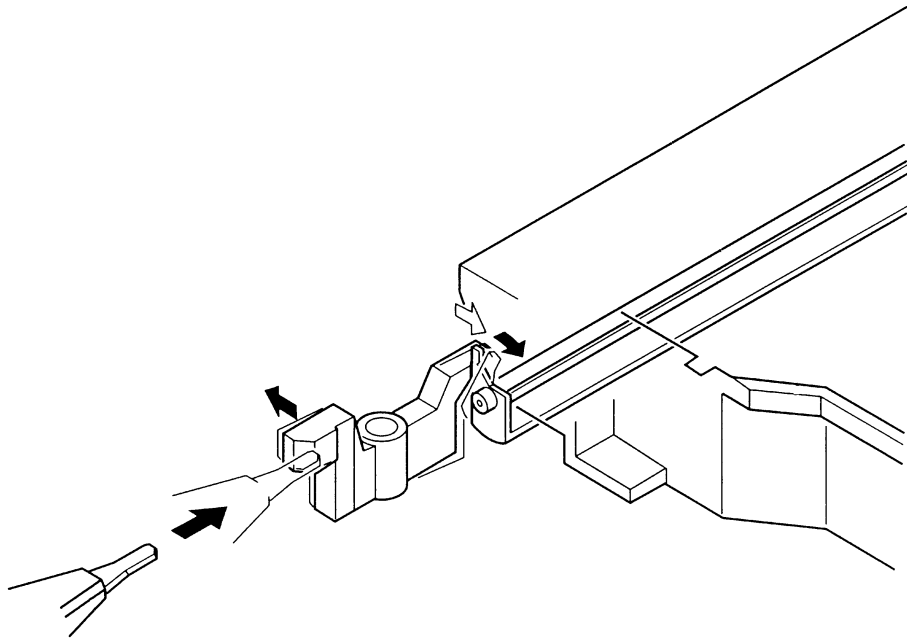
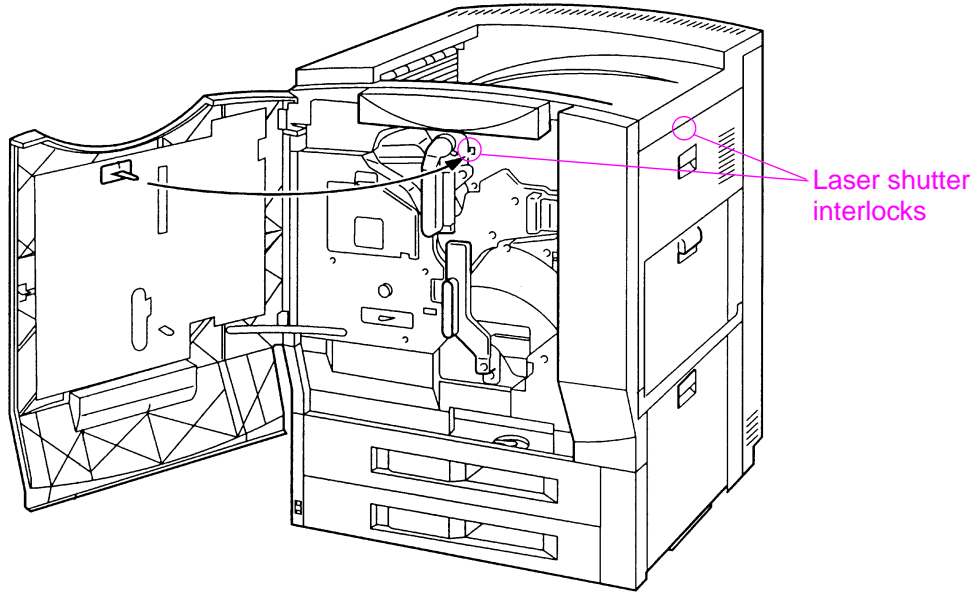


**Figure 185.** Toner carousel door detection interlock

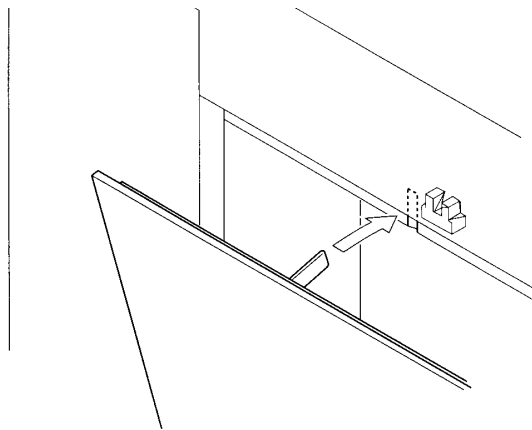


**Figure 186.** Front cover/delivery cover detection interlocks

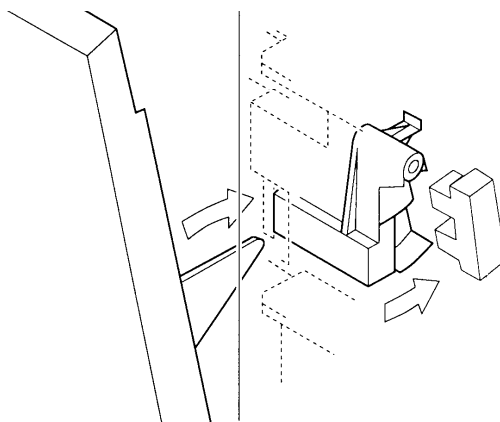
## Laser shutters



**Figure 187.** Laser shutters



**Figure 188.** Left upper cover detection



**Figure 189.** Right lower cover detection



## Service mode formatter diagnostics

- 1 From the Service Mode Menu, press **MENU** until FORMATTER DIAGNOSTICS appears.
- 2 Press **SELECT**. WARNING MEMORY LOSS appears on the printer control panel briefly. Then EXECUTE TESTS appears.
- 3 Press **ITEM** until one of the following tests appears on the printer control panel:
  - **ROM CRC** — The read-only memory cyclic redundancy check reads the values stored in the firmware ROMs, computes checksum variables based on the read information, and compares the computed checksums with those stored in the ROM.
  - **DRAM DIMMS** — Installed DIMMs are tested to ensure that they are supported by the formatter board and are functioning properly. The time that this test takes to run varies depending on the amount of memory installed. DRAM DIMMs are tested using a pattern test, an address test, and a walking ones test.
  - **IDE ASIC** — This test is performed on the IDE ASIC of the formatter board to ensure read and write integrity. Values are written to the ASIC registers and then read for verification.
  - **DISK** — The disk drive test does the following:
    - a instructs the disk drive (if installed) to perform its internal self-test (similar to a power-on test)
    - b enters into sleep mode and wakes up again
    - c seeks and reads sequential sectors forward for 30 seconds
    - d seeks and reads sequential sectors backward for 30 seconds
    - e seeks and reads random sectors for 30 seconds
    - f performs read and write tests
  - **VX ASIC** — This test is performed on the VX ASIC of the formatter board to ensure read and write integrity. Values are written to the ASIC registers and then read for verification.
- 4 Press **- VALUE +** until ON or OFF appears on the display.
- 5 Press **SELECT**.
- 6 Press **ITEM** until EXECUTE TEST appears on the printer control panel display.
- 7 Press **SELECT**.

---

**Note**

Turn the printer off and on to exit the formatter diagnostics.

## Cold reset

The following are effects of performing a cold reset:

- While a cold reset is being performed, all control panel keys are ignored.
- A cold reset changes all user-accessible printer variables stored in NVRAM to their factory defaults except for the following items:
  - page counts
  - fuser life count
  - transfer life count
  - multi-bin mailbox mode
  - display language
- Color adjust values revert to the factory defaults.
- User-accessible EIO values are reset to the factory defaults by a cold reset.
- None of the service mode variables such as the following are affected by a cold reset:
  - serial numbers
  - model name
  - model number
  - registration values
  - cold reset paper size
- The event log is not cleared.

### Performing a cold reset

- 1 Print a configuration page (see page 361) to record the previous printer settings.
- 2 Turn the printer off.
- 3 Hold down **Go** while turning the printer on. Release **Go** after COLD RESET appears on the printer control panel display.

COLD RESET (in English) appears on the display for one second to verify that the key sequence has been recognized, followed by the power-on self-test message.

Once the power-on self-test is finished, the message RESTORING FACTORY SETTINGS displays in English.

## Fault log

The fault log is implemented within the formatter diagnostics to record error messages. This log provides service personnel with an account of all errors that occurred while the formatter diagnostics tests were executing. This log is completely separate from the event log. No entries are made in the event log for any diagnostic mode failure.

## Error message logging

When a test in formatter diagnostics detects an error, the Attention LED is lit and a message describing the error is added to the fault log. The fault log holds a maximum of 50 entries. When the fault log is full and a new message needs to be added, the oldest message is discarded. The contents of the fault log are erased when the printer is powered off or when the fault log is cleared.

## Viewing the fault log

The fault log menu appears as an Item selection only when one or more error messages exist in the log. The fault log menu is entered automatically at the end of a test run if any error messages were recorded. If there are items in the fault log to be viewed, the fault log can be entered by using **ITEM** to view the fault log entry.

## Error message format

Each error message has the form:

*mm.NAME\_t<description>[<data>]*

where:

mm	Message number in the fault log, 1 being the oldest message
NAME	Name of the test that found the failure
t	Error number within the test
<description>	Type of failure
<data>	Pertinent data related to the failure

## Paper path troubleshooting

### General paper path checklist

- Verify the green lever on the fuser is down.
- Check that the post charger cleaner is pushed all the way to the right. Media jams could occur when it is out of place.
- Clean the printer. Toner and paper dust in the paper path inhibit free movement of media through the printer and block the sensors.
- Vary the input and output selections of the printer to determine if the problem is associated with a particular area of the printer.
- Worn separation rollers on the input tray cause last-page multi-feeds. Check the condition of the pick-up rollers and separation rollers when troubleshooting multi-feeds. Bent separation tabs cause misfeeds and multi-feeds. Replace the tray if necessary.
- Defective input tray switches can cause media jams by indicating the wrong size media to the formatter board.
- Scraps of paper left in the paper path can cause intermittent media jams. Always check that the paper path is clear when cleaning the printer and when clearing media jams. Also, remove the fuser and carefully check it for jammed media.
- Reduce curl of black-only transparencies by:
  - placing the transparencies in a presentation sleeve
  - printing to the left (face-up) output bin
- Verify the media requirements starting on page 26 are met.

### Wrinkled pages

- Verify the green fuser lever is down.
- Verify the media size and type are set correctly in the printer driver and the printer control panel.
- Verify the media meets the specifications listed in the *HP LaserJet Printer Family Paper Specification Guide*.

## Sealed envelopes

To prevent envelopes from sealing in the printer, set the envelope size in the printer driver as a custom size. However, setting envelopes as a custom size can cause poor fusing.

## Media jams

When troubleshooting media jams, remember that jams are posted as a result of timing errors. That is, media fails to arrive at, or fails to clear the paper path sensor in the allotted time. The paper path timing is set by the controller board. Stuck or defective sensors cause the paper path timing to post a jam message at power on, as do scraps of paper caught in the paper path.

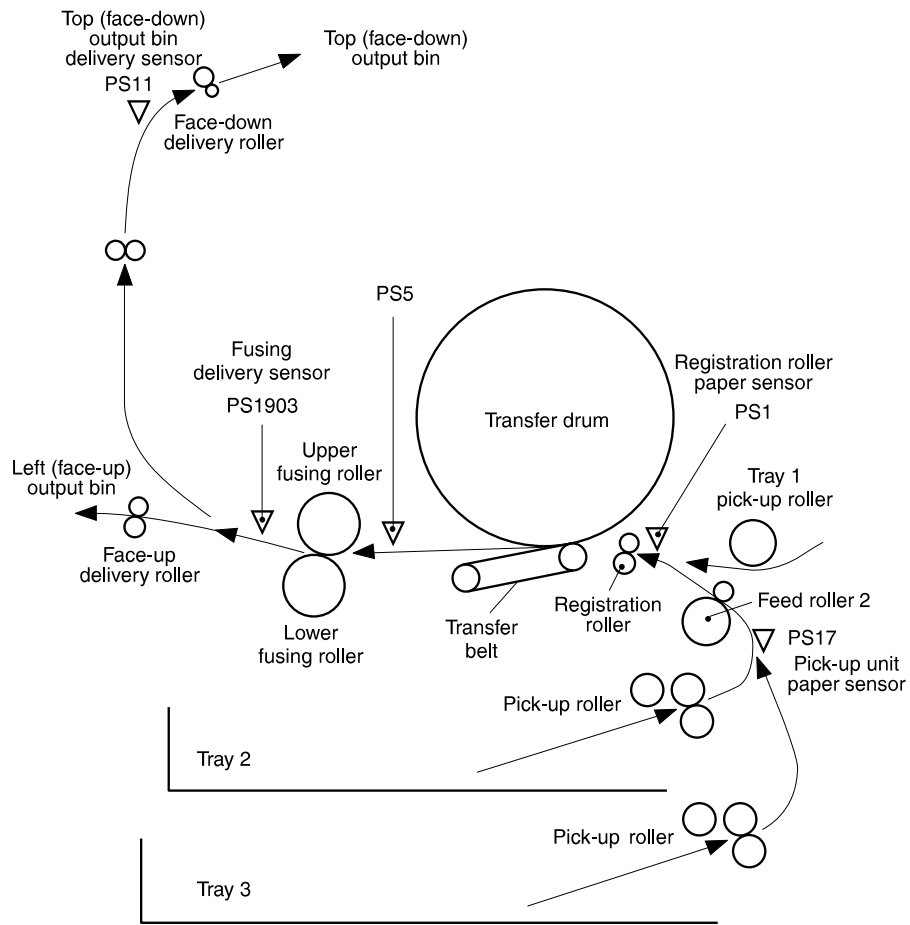
Use figure 190 to locate the paper path sensors. The media jam message code identifies the sensor that failed to change state in the required time.

---

**Note**

Check that the paper path sensors are free throughout their full range of travel. All interlock switches must be operational in order for the printer to clear media jam messages.

---



**Figure 190. Printer paper path**

For information on printer and paper handling accessory sensors, see chapter 5.

Following are possible media jams:

**Table 42. Media jam detection**

Location of jam	Detected when . . .
Pick-up delay jam 1	<p>The page has not reached the pick-up unit paper sensor (PS17) within about:</p> <ul style="list-style-type: none"> <li>● 1.2 seconds after leaving tray 2</li> <li>● 1.3 seconds after leaving tray 3</li> </ul>
Pick-up delay jam 2	<p>The media does not reach the registration roller paper sensor (PS1) within about:</p> <ul style="list-style-type: none"> <li>● 1.9 seconds after leaving tray 2</li> <li>● 2.0 seconds after leaving tray 3</li> <li>● 1.8 seconds after leaving tray 1</li> </ul>
Transfer jam	<p>The separation sensor (PS5) does not detect the media for the specified time or longer within 1.5 to 2.2 seconds after the top of paper signal:</p> <ul style="list-style-type: none"> <li>● about 0.1 seconds (normal mode)</li> <li>● about 0.4 seconds (overhead transparency mode)</li> <li>● about 0.3 seconds (high-gloss mode)</li> </ul>
Fusing delivery paper delay jam	<p>The media has not reached the fusing delivery sensor (PS1903) since the top of paper signal within about:</p> <ul style="list-style-type: none"> <li>● 3.2 seconds (normal mode)</li> <li>● 12.8 seconds (overhead transparency mode)</li> <li>● 9.6 seconds (high-gloss mode)</li> </ul>
Fusing delivery stationary jam	<p>The media has not passed through the fusing delivery sensor (PS1903) within the specified time after PS1903 detects the leading edge of the media within about:</p> <ul style="list-style-type: none"> <li>● 2.4 seconds (normal mode/letter-sized media landscape)</li> <li>● 9.6 seconds (overhead transparency mode/letter-sized media landscape)</li> <li>● 7.2 seconds (high-gloss mode/letter-sized media landscape)</li> <li>● 4.2 seconds (normal mode/11-by-17 inch-sized media)</li> <li>● 17.0 seconds (overhead transparency mode/11-by-17 inch-sized media)</li> <li>● 12.7 seconds (high-gloss mode/11-by-17 inch-sized media)</li> </ul>
Fusing unit paper coil jam	<p>The fusing delivery sensor (PS1903) does not detect the media for the specified time or longer within 0.2 to 1.2 seconds after PS1903 detects the leading edge of the media within about:</p> <ul style="list-style-type: none"> <li>● 0.8 seconds (normal mode)</li> <li>● 3.2 seconds (overhead transparency mode)</li> <li>● 2.4 seconds (high-gloss mode)</li> </ul>

**Table 42. Media jam detection (continued)**

Location of jam	Detected when . . .
Top (face-down) output bin delivery delay media jam	<p>The media has not reached the top (face-down) output bin delivery sensor (PS11) within the specified time after the fusing delivery sensor (PS1903) detects the media:</p> <ul style="list-style-type: none"> <li>● about 4.0 seconds (normal mode)</li> <li>● about 16.0 seconds (overhead transparency mode)</li> <li>● about 12.0 seconds (high-gloss mode)</li> </ul>
Top (face-down) tray delivery stationary jam	<p>The media has not passed through the top (face-down) output bin delivery sensor (PS11) within the specified time after PS11 detects the media within about:</p> <ul style="list-style-type: none"> <li>● 2.4 seconds (normal mode/letter-sized media landscape)</li> <li>● 9.6 seconds (overhead transparency mode/letter-sized media landscape)</li> <li>● 7.2 seconds (high-gloss mode/letter-sized media landscape)</li> <li>● 4.2 seconds (normal mode/11-by-17 inch-sized media)</li> <li>● 17.0 seconds (overhead transparency mode/11-by-17 inch-sized media)</li> <li>● 12.7 seconds (high-gloss mode/11-by-17 inch-sized media)</li> </ul>
Wrong media size feed jam	<p>The controller board detects media size with the registration roller paper sensor (PS1), and it stops the engine if the media size differs more than 15 mm between the specified media size and the actual media size. On the other hand, if the difference is within +7.5 to 15 mm, or -3.7 mm or more, the media is automatically delivered.</p>
Door-open jam	<p>The sensors listed below detect the media when a cover is opened or closed:</p> <ul style="list-style-type: none"> <li>● registration paper roller sensor (PS1)</li> <li>● pick-up unit paper sensor (PS17)</li> <li>● separation sensor (PS5)</li> <li>● top (face-down) output bin delivery sensor (PS11)</li> <li>● fusing delivery sensor (PS1903)</li> </ul>
Initial residual jam	<p>The sensors listed below detect the media the specified time after the power switch is turned ON:</p> <ul style="list-style-type: none"> <li>● separation sensor (PS5)</li> <li>● fusing delivery sensor (PS1903)</li> </ul>



## Image formation troubleshooting

Before beginning image formation troubleshooting:

- 1 Verify the media type is set correctly in the printer control panel, and that the media type selected in the printer driver matches the media being printed on.
- 2 Verify that the media meets the specifications listed in the *HP LaserJet Printer Family Paper Specification Guide*. The following media-related items are responsible for many image formation and print-quality defects:
  - rough paper
  - heavy paper (heavier than 58 lb, 216 g/m<sup>2</sup> bond)
  - transparencies out of the specified thickness range (thicker than 0.5 mil)
  - paper that has absorbed moisture from the atmosphere
  - room environment (humidity too high or low)
- 3 Print a configuration page. The configuration page tests the ability to print each primary and process color. For information on printing a configuration page, see page 361.

In addition to items listed above, the configuration page does the following:

- shows that all colors print
  - checks that the room humidity is within specifications
  - shows varying levels of color
  - shows that the formatter board is working properly
- 4 Print a demonstration page to check the following:
    - image quality
    - half-tones
    - process colors

## Understanding color variations

The printed output might not match the computer screen, and the colors printed on successive pages might not match. While color variations are inherent in this printing method, they also might indicate changes in the printing environment, print media, or printer components.

## Common causes of color variation

The following list outlines the major causes of color variations between computers, applications, and output devices.

- Half-tone patterns produced on monitors and the types of patterns used in the print jobs are different and might cause apparent differences between the printed output and the screen.
- Different papers have different color, brightness, and gloss, which will affect the color appearance.
- Printed colors with identical CMYK or RGB values but with a different half-tone (ColorSmart, text, graphic, or image) might look different when printed. Select the custom colors option in the driver (manual color) and change the half-toning options to vary the shading and quality of the colors.
- The printed output differs from the image on the monitor because the monitor and the print media have different reference values for black and white. The monitor screen has charcoal gray for the black level, and the white on the monitor screen is actually a light blue. Black on the print media is limited only by the fill capability of the printer, and most good-quality paper has a very high white level. In addition, phosphor (used in color monitors) and toner have entirely different spectra characteristics and different color rendering capabilities. Blues generally match better than reds.
- The color of the ambient light changes the perception of color. Fluorescent light lacks emphasizes different colors than incandescent light, and the color range of natural light is broader than any artificial light. When comparing color, choose a standard light source for reference and understand that the perceived color will change as the light changes.
- Long-term color variations occur as the paper ages. Use high quality paper and protect the paper from sunlight to help minimize discoloration.
- Environmental changes can cause color variation. The development process places a high potential across an air gap to attract toner to the imaging drum. Changes in relative humidity vary the point at which the toner travels to the imaging drum. The

printer has a humidity sensor that adjusts operating parameters as the humidity changes to minimize the effects of environmental changes.

- All consumable components have a finite life span, and as these components reach the end of their useful life, their ability to produce consistent print quality diminishes.
- When printing on transparencies, **OHT** must be selected in the printer driver in order for the colors to be treated properly on the transparencies.

### **Color selection process**

The user selects the color in the application, but the operating system might convert or modify some characteristics of the color before sending the information to the printer driver. The printer driver might also modify color characteristics depending upon the selected output mode.

Any color characteristics not addressed by the printer driver or applications are set to the printer default. The default color might not match the color the user selected.

Some applications (such as Adobe® PageMaker, Illustrator, and Photoshop™) bypass the printer driver altogether. If color information is not sent, the printer has no way of knowing the white point, black point, and chromaticity assumptions used by the application. This mismatch can cause color differences.

### **Matching screen colors**

Matching input, on-screen, and output colors is a very sophisticated process. The input device software and output device each influence the ability to select and produce printed color output. To improve color matching between the printed output and the monitor:

- Turn off any color matching feature in the software that does not specifically mention ColorSync, ICM, or ICC.
- Calibrate the monitor. One option for monitor calibration is the Colorific software included on the color productivity CD.
- If a color management system is being used, make sure the input (monitor) and output (composite) profiles are correct.
- If a color management system is available, try turning it off or on to see if changing the setting changes the color match.
- Compare monitor and output colors by placing the output in a neutral surrounding 18 to 24 inches (46 to 61 cm) away from the monitor. This will help the eye make the transition from the monitor white point (blue) and the paper white point.

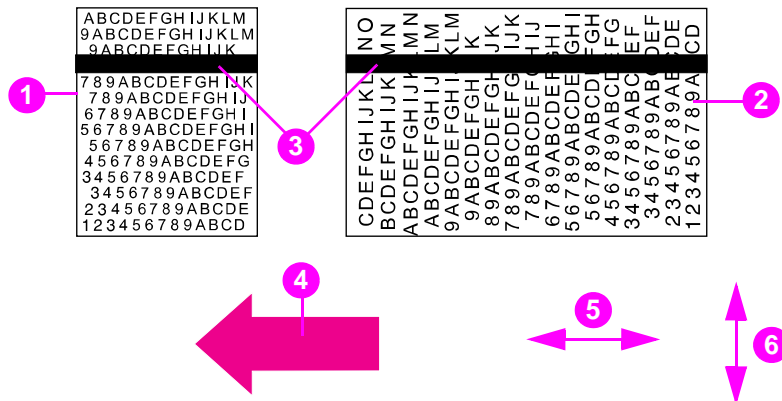
## Image defects troubleshooting

### Image orientation

Unless otherwise specified, all references in this section to horizontal or vertical directions of print quality problems refer to problems found on letter- and A4-sized media. These media sizes are fed into the printer long edge first.

Because media sizes other than letter or A4 are fed into the printer short edge first, the orientations of print quality problems are the opposite of those on letter- or A4-sized media. Print quality problems that appear horizontally on a letter- or A4-sized page when it is held with the short edge up run vertically on other media sizes when the page is held with the short edge up. The same is true for a vertical defect on a letter- or A4- sized page; it will appear as a horizontal defect on other sizes of media.

The following figure shows a print quality problem printed on both a letter- or A4-sized page and the same defect on an 11-by-17 inch or A3-sized page (or any other size of media).



**Figure 191.** Image orientation and direction of travel

- 1 Letter- or A4-sized media
- 2 11-by-17 inch or A3-sized media (or any other size of media)
- 3 Print quality problem
- 4 Direction media moves through the printer (process direction)
- 5 Direction streaking occurs on pages
- 6 Direction banding occurs on pages

---

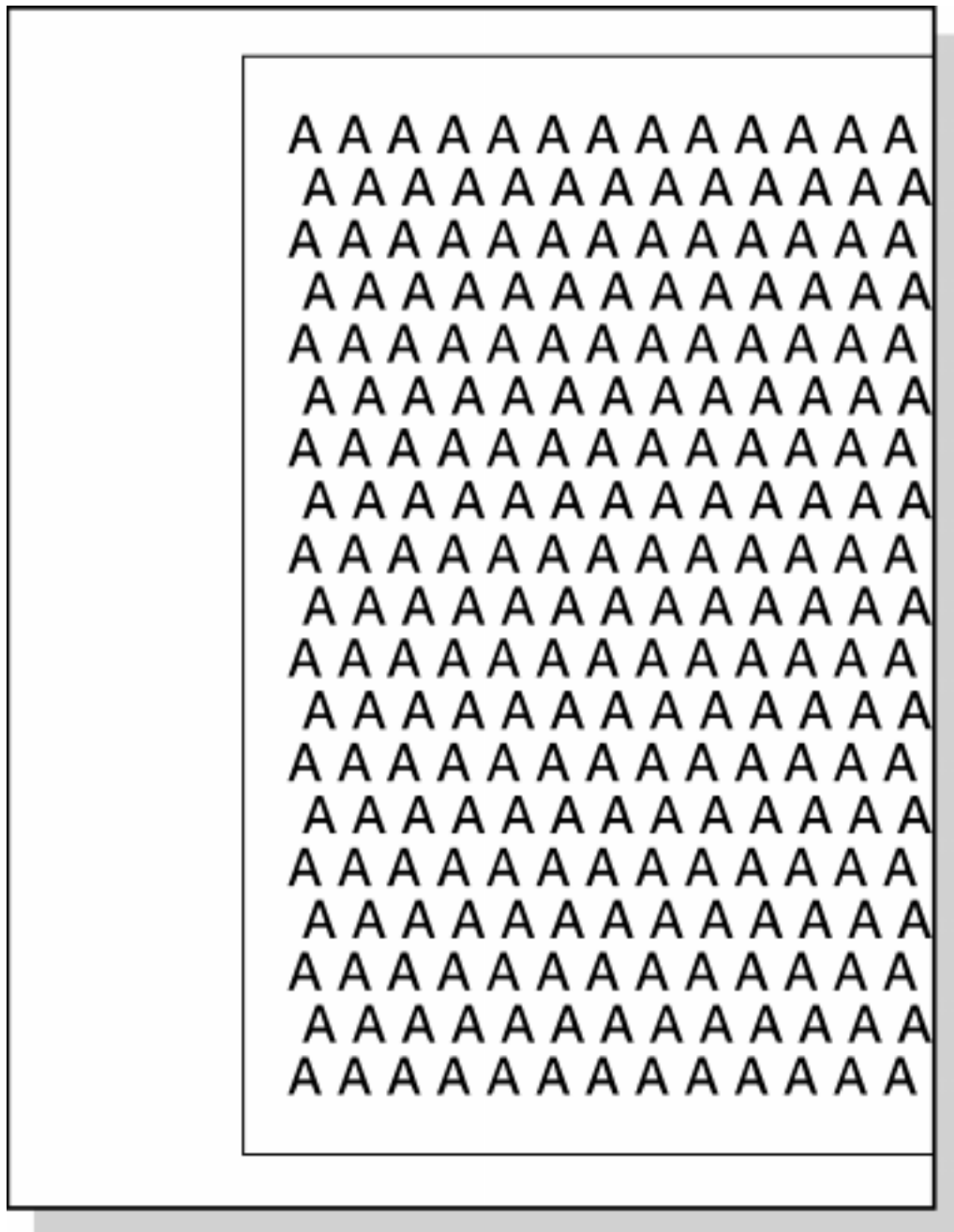
**Note**

PostScript print samples are located on the service and support CD (which is included with your service manual). Print these files by copying them to the parallel port (LPT 1), for example:  
`copy magnta.ps lpt1`

---

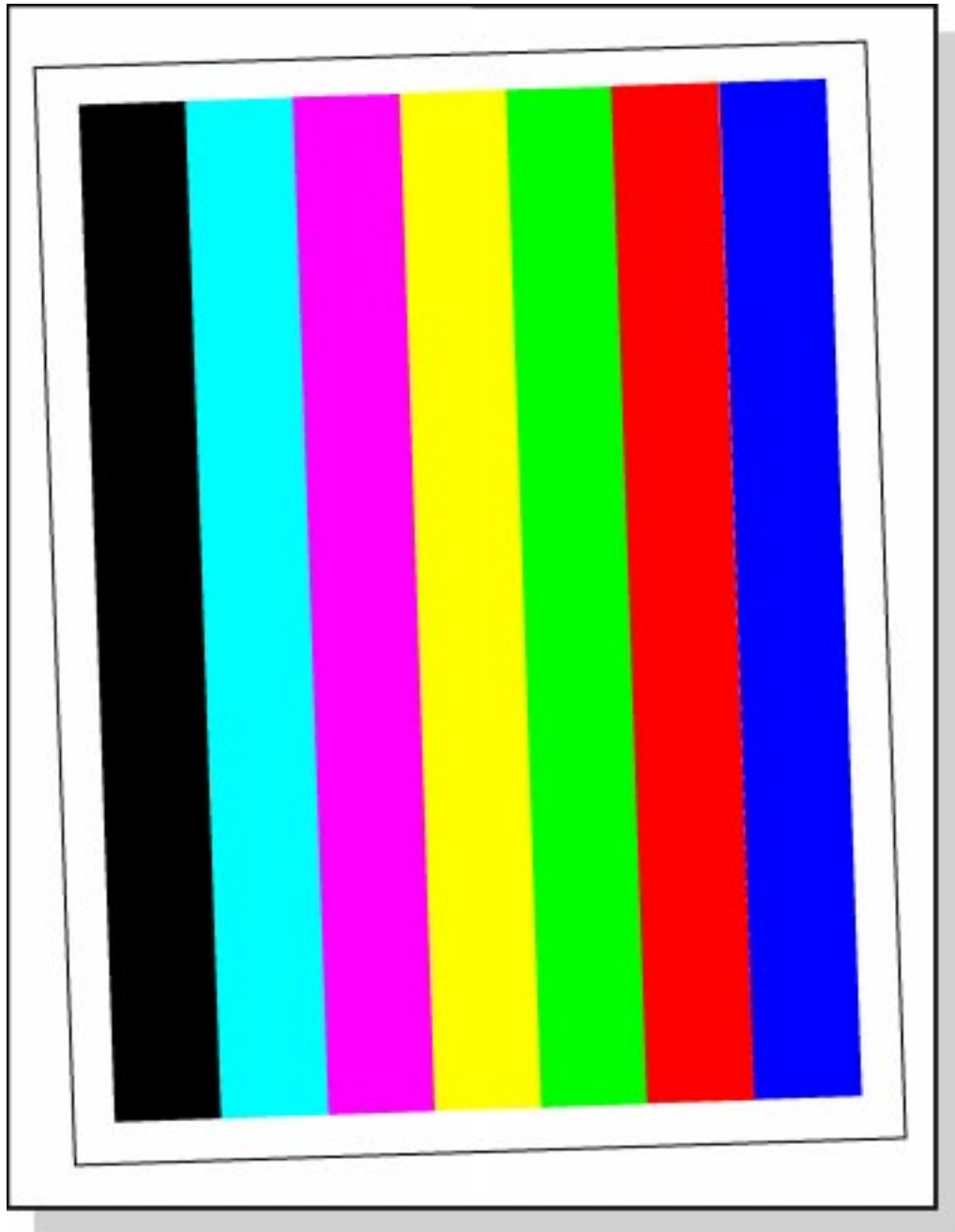
## Image defect examples

Figures 192 through 202 show examples of image defects. Resolutions for these defects follow the illustrations.



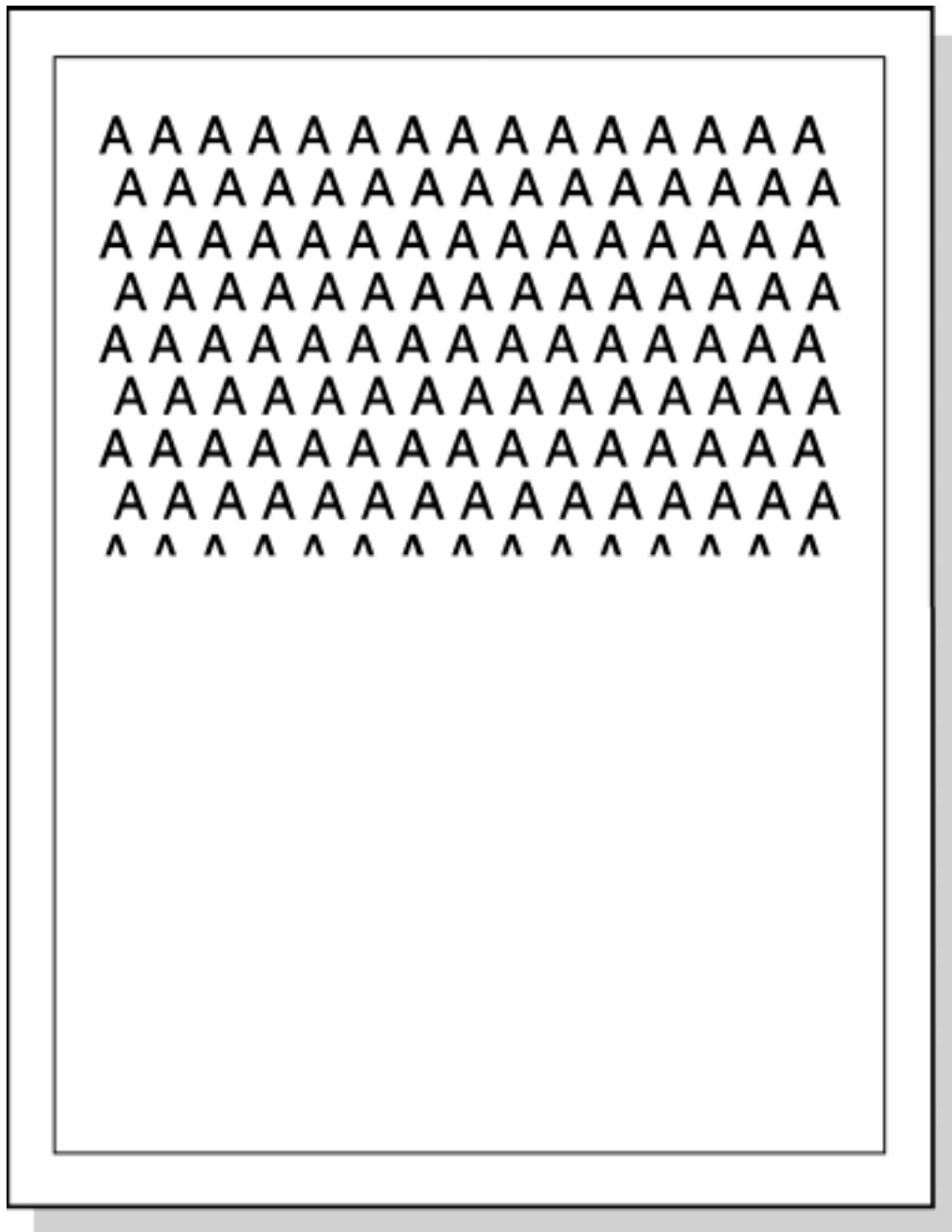
**Figure 192.** Incorrect registration (late and early print)

See page 399 for a resolution to this print defect.



**Figure 193.** Image skew

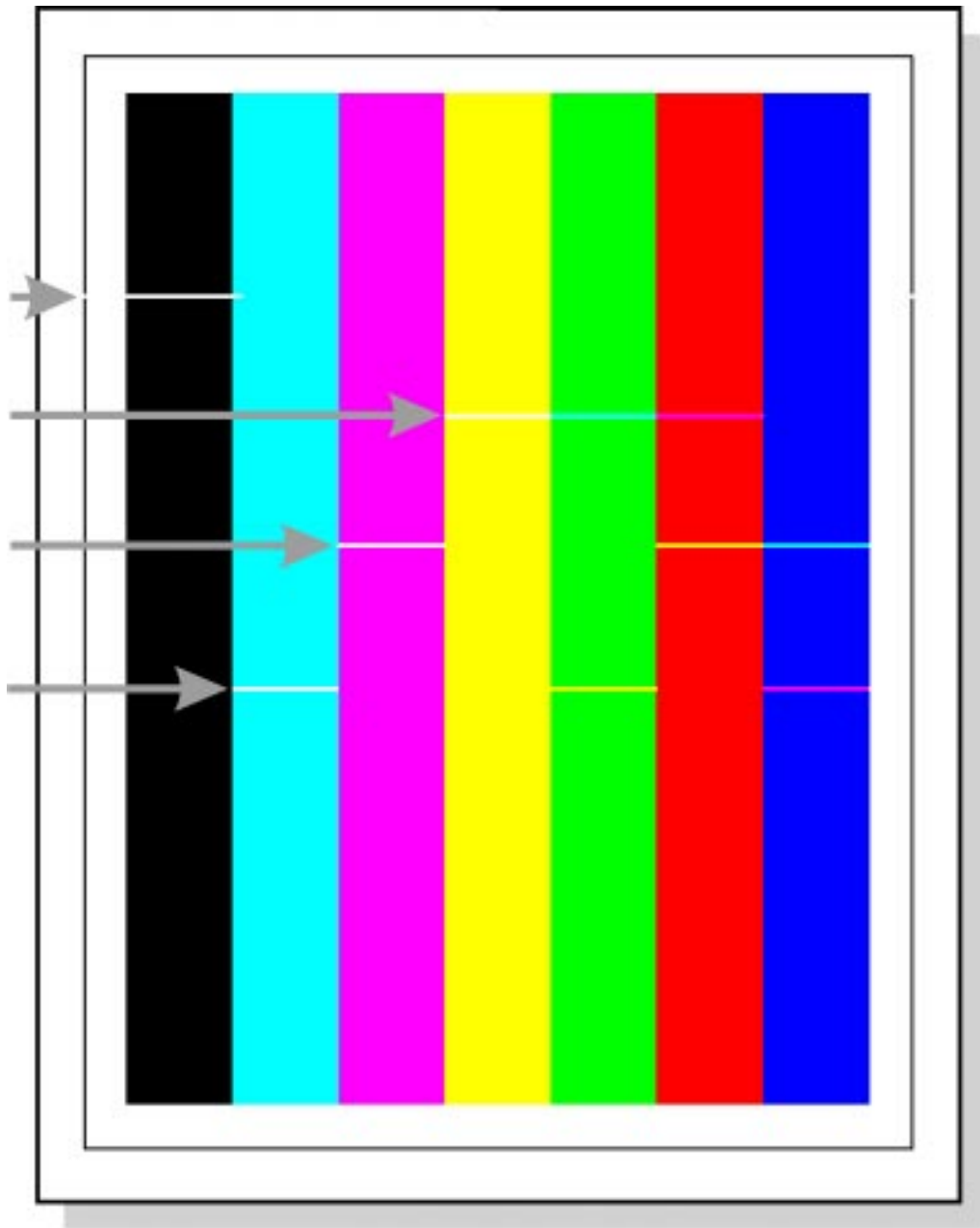
See page 399 for a resolution to this print defect.



**Figure 194.** Blank or partially blank page

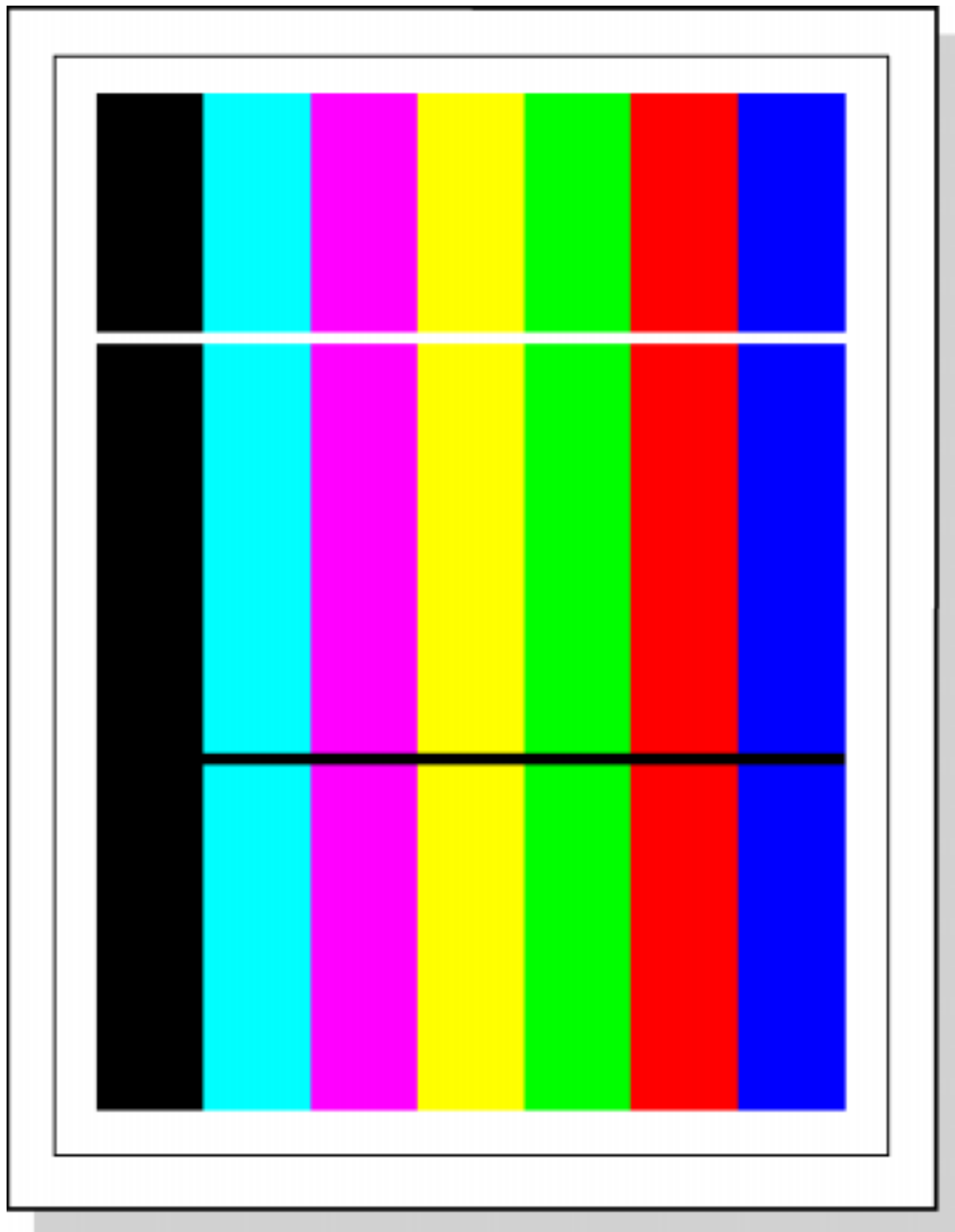
See page 400 for a resolution to this print defect.





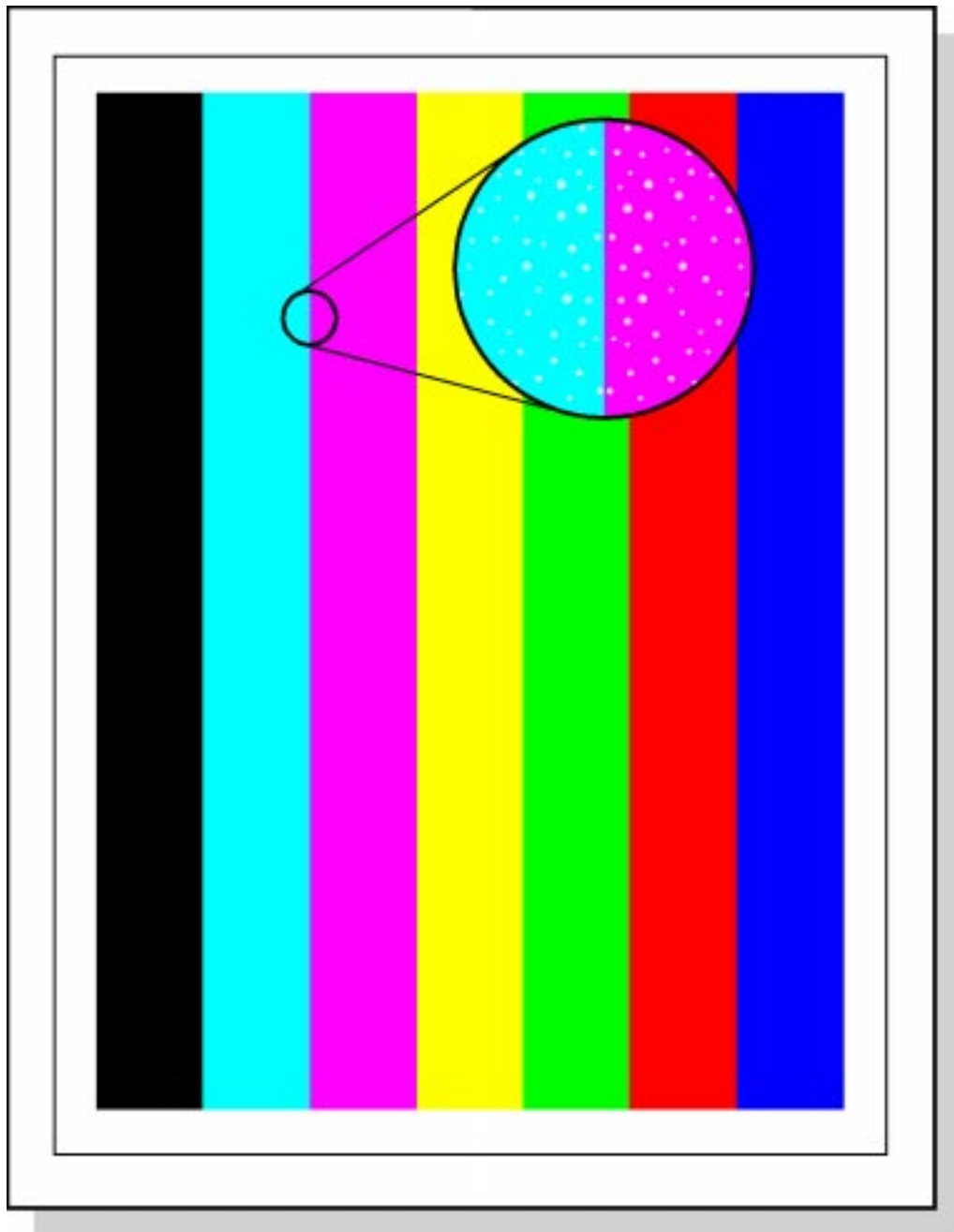
**Figure 195.** Horizontal lines (in one color)

See page 401 for a resolution to this print defect.



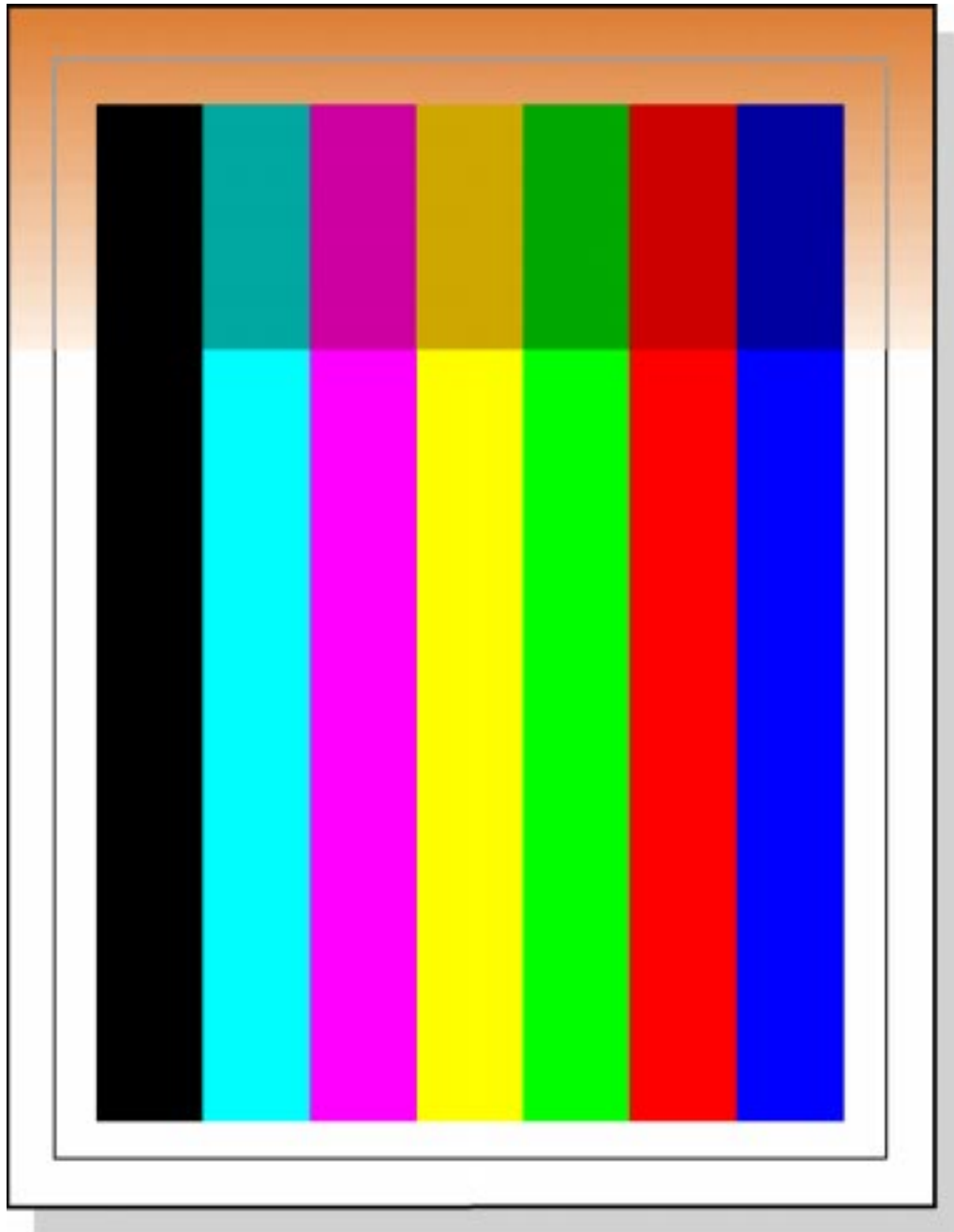
**Figure 196.** Horizontal lines (in all colors, CMYK)

See page 402 for a resolution to this print defect.



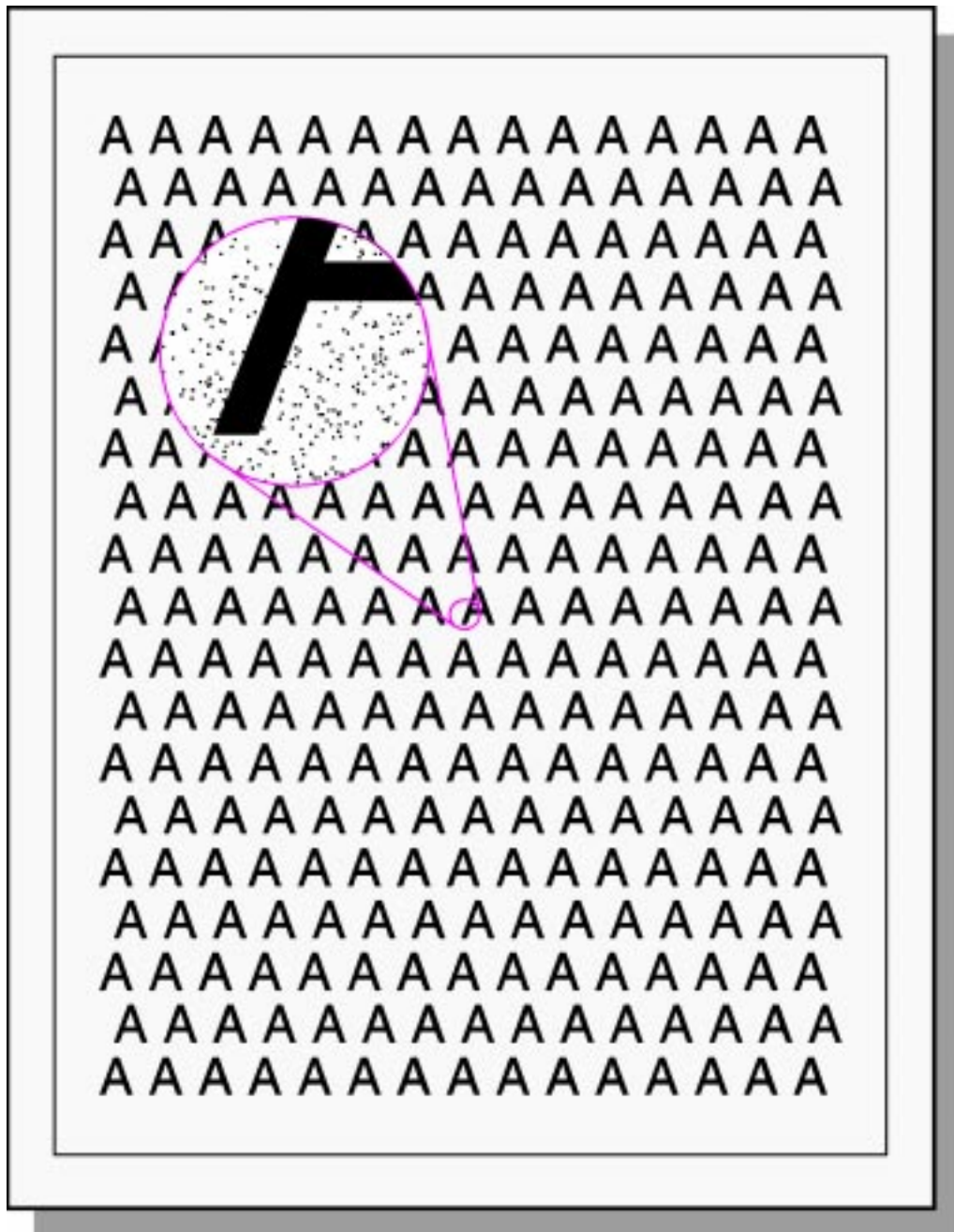
**Figure 197.** Rain or speckled print

See page 403 for a resolution to this print defect.



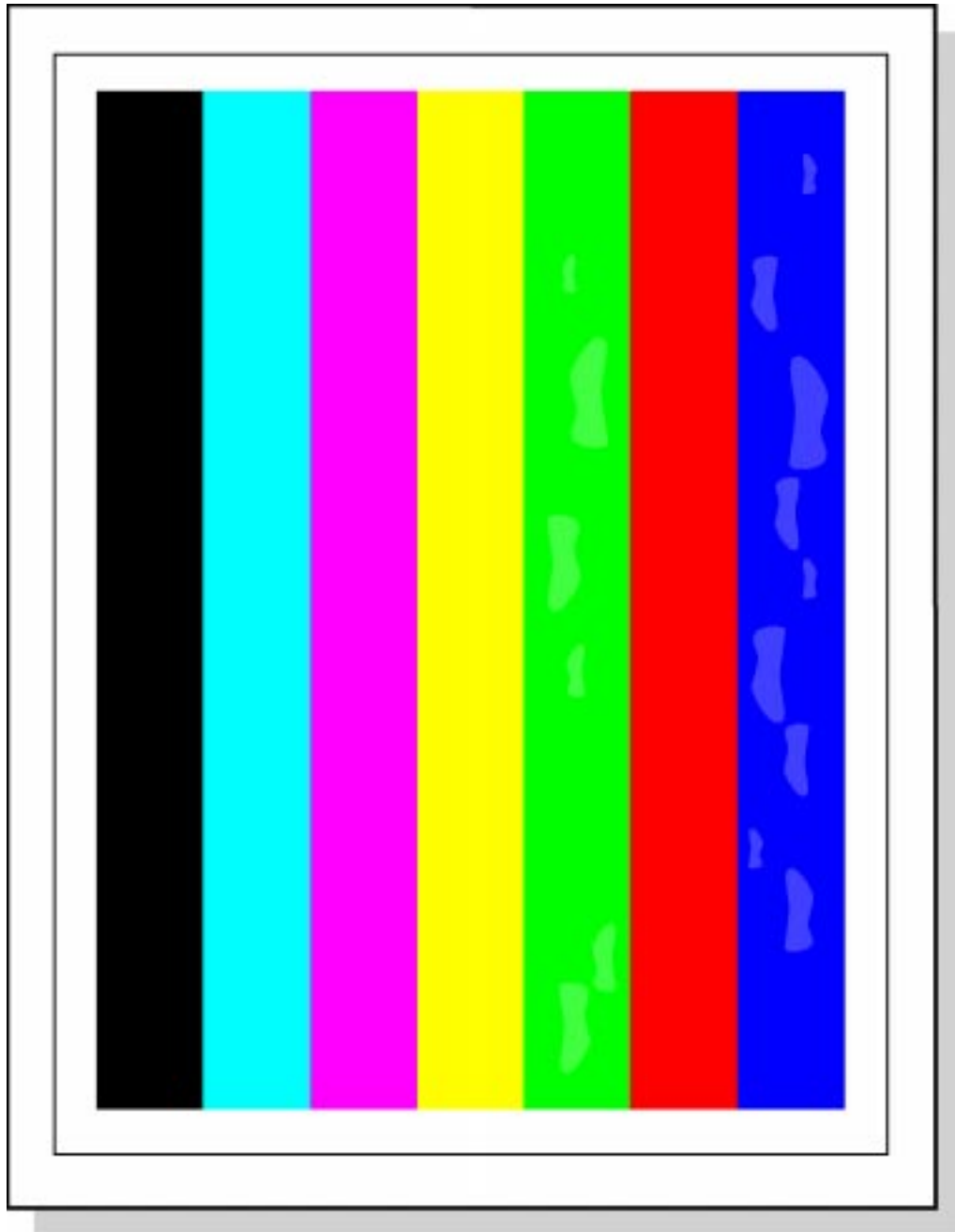
**Figure 198.** Black, brown, or orange bands

See page 407 for a resolution to this print defect.



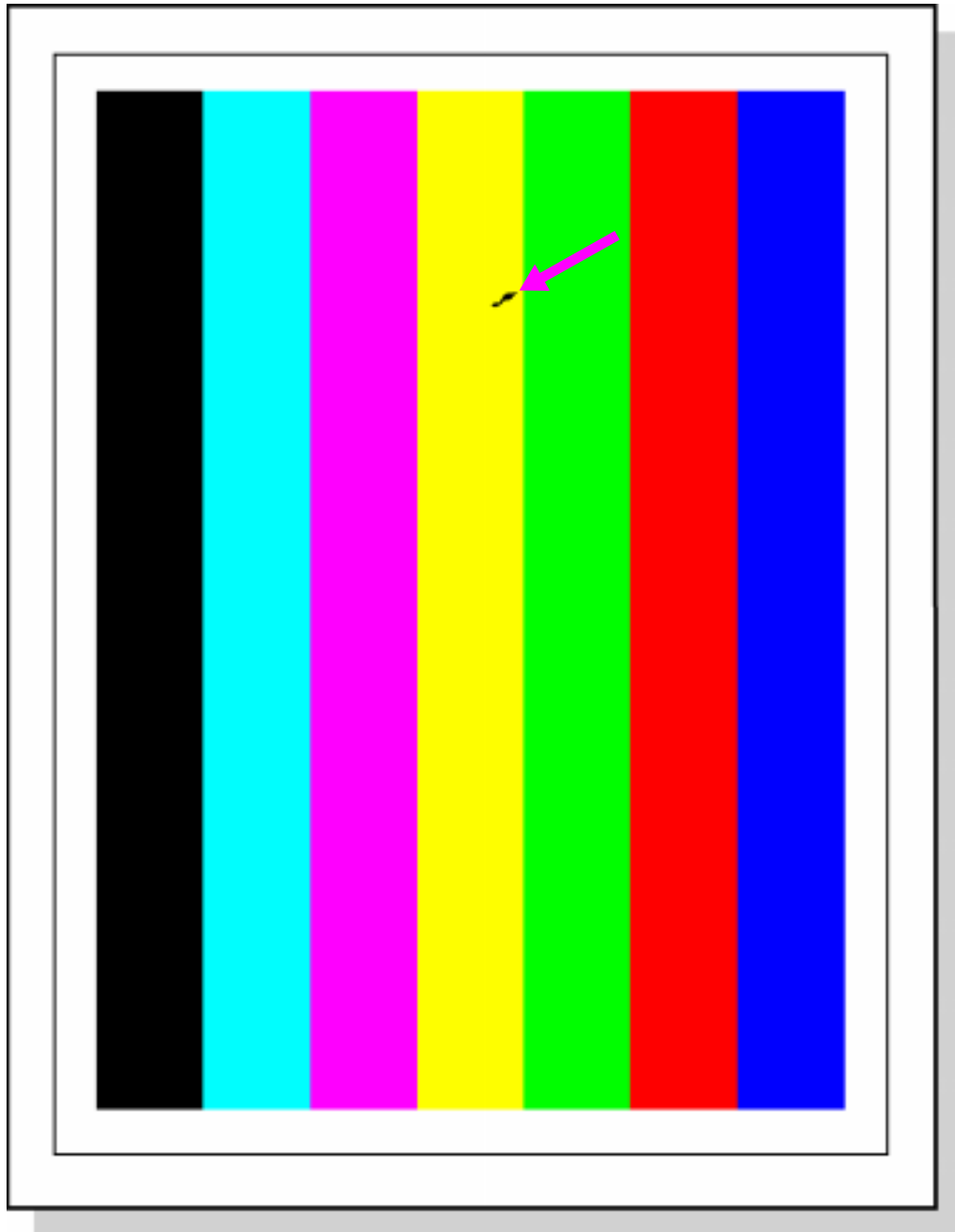
**Figure 199.** Background toner scatter

See page 407 for a resolution to this print defect.



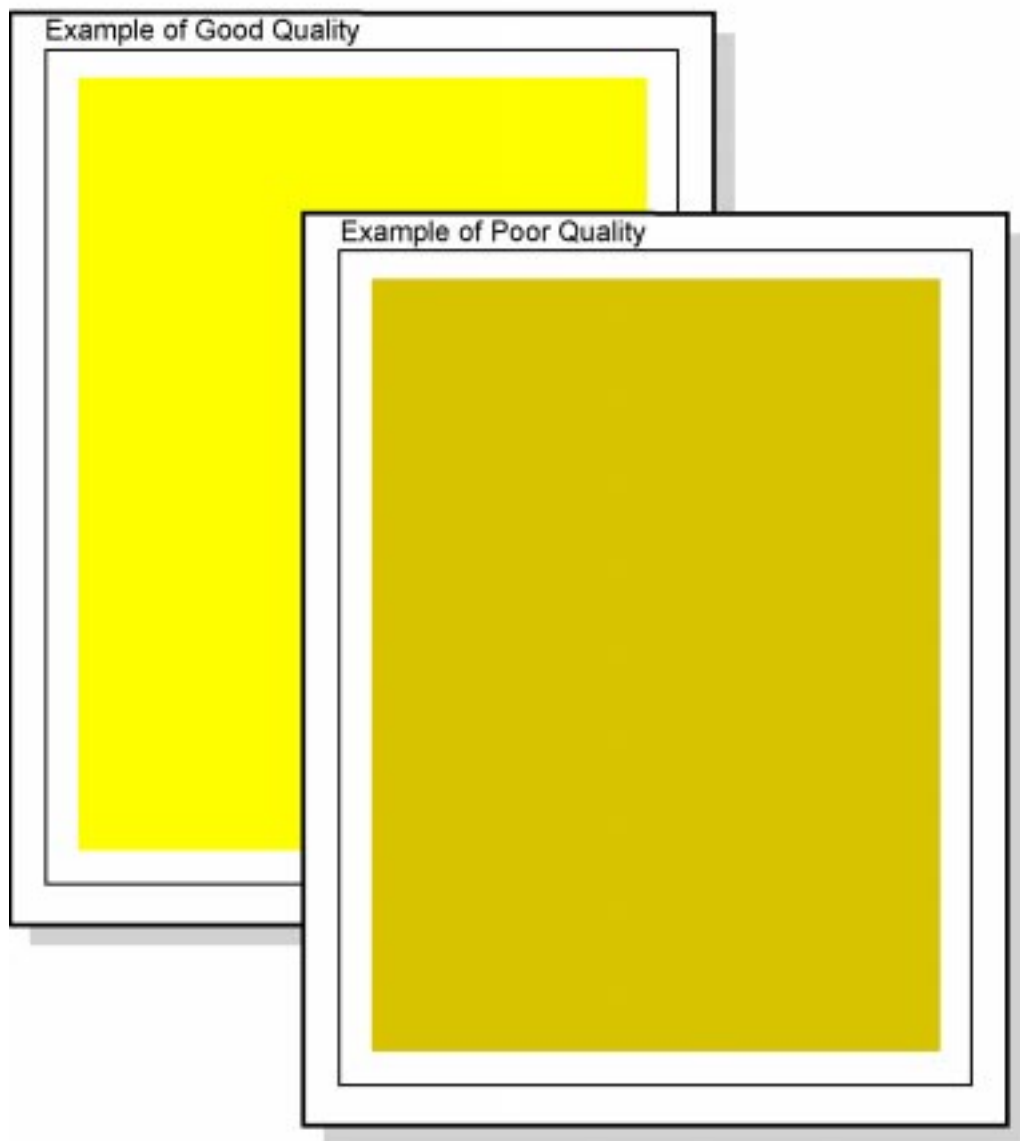
**Figure 200.** Mottled process colors or poor transfer

See page 408 for a resolution to this print defect.



**Figure 201.** Stray toner

See page 410 for a resolution to this print defect.



**Figure 202.** Dark yellow or contaminated print

See page 413 for a resolution to this print defect.



## Incorrect registration (late and early print)

(See figure 192 on page 388 for an example.)

Incorrect registration is when the entire image is offset from the leading edge of the page (the left edge for letter- and A4-sided media, and the top of the page for all other media sizes). Before troubleshooting incorrect registration as an engine problem, check the margins and image placement in the software application. If the same file consistently prints in the wrong location on the page, suspect a software problem.

If the image is late on the page, the paper is arriving at the drum/transfer interface too soon. Check engine settings 1 and 2 in the Service Mode Menu to ensure that the values match the registration sticker on the printer (inside the front of the printer, to the left of the printer control panel); however, the last two digits of the engine settings might vary from those printed on the sticker.

## Image skew

(See figure 193 on page 389 for an example.)

The specification for image skew is less than 1.5 mm over a 250-mm span. Image skew might be caused by burrs on the paper registration plate, or paper not feeding from the paper tray correctly.

- Check that the media does not stick together at the edges. Verify that the media meets the specifications listed in the *HP LaserJet Printer Family Paper Specification Guide*.
- Ensure the media guides are adjusted properly against the edge of the media.
- Carefully examine the printed output for signs of nicking or folding. These marks might indicate problems elsewhere in the paper path. For instance, imperfections in a paper guide might stop the page inside the printer.
- Check the paper pick-up rollers for signs of wear, such as glazing and cracking. Replace the pick-up rollers, if necessary.

## Blank or partially blank page

(See figure 194 on page 390 for an example.)

- Print a configuration page and listen for the carousel to rotate at least twice. Open the right upper door and remove the transfer drum. If the image does not appear on the transfer drum, look for obstructions in the scanner shutters.
- Verify that the media meets the specifications listed in the *HP LaserJet Printer Family Paper Specification Guide*.
- Use the continuous configuration page to prove the printer feeds paper reliably. Rough media or light media might cause the printer to feed multiple pages, which results in blank output.
- Check for host communications problems, or problems in the network configuration.
- Check for banner pages and form feed commands in the software.
- Verify that the number of lines per page is correct. Too many lines per page results in “creeping text.” In this condition, each successive page begins its print further down the page. Part of each page is blank.
- If random lines are missing from the page, print a configuration page. If the error still occurs, upgrade the firmware by installing firmware upgrade DIMMs. If the condition persists, replace the formatter board.
- Check for scanner failure. Turn the printer off and on to reset the scanner.

## Horizontal streaks (in one color)

(See figure 195 on page 391 for an example.)

- Horizontal lines might occur because of low toner. Check the printer control panel display for a TONER LOW REPLACE <color> or TONER OUT REPLACE <color> message.
- Dark or light horizontal lines or streaks appearing in colors might occur because of a defective toner cartridge. Use the service and support CD to help troubleshoot print quality problems by printing slimlt21.ps and vcolt21.ps on letter-sized paper or slima421.ps and vcola421.ps on A4-sized paper from tray 2. Type the following command at the DOS prompt to print the files:  
`copy <file name> lpt1`
- Use the table below to diagnose which toner cartridge is causing the streaking problems. Replace the toner cartridge if necessary.

**Table 43. Streaking**

<b>If the streak is only in . . .</b>	<b>The problem is in . . .</b>
Red, Yellow, Green	Yellow toner cartridge
Red, Magenta, Blue	Magenta toner cartridge
Green, Cyan, Blue	Cyan toner cartridge
Black	Black toner cartridge

## Horizontal streaks (in all colors, CMYK)

(See figure 196 on page 392 for an example.)

- Inspect the paper path and the transfer area for foreign materials that might be coming in contact with the unfused image.
- The post charging unit or transfer charger might be contaminated. Clean both as described on page 99 and page 101.
- Check for obstructions and contamination in the scanning area.
- Use the service and support CD to help troubleshoot print quality problems by printing `slimlt21.ps` and `vcolt21.ps` on letter-sized paper or `slima421.ps` and `vcola421.ps` on A4-sized paper from tray 2. Type the following command at the DOS prompt to print the files:  

```
copy <file name> lpt1
```
- Look for an imaging drum defect. Replace the imaging drum, if necessary.
- Inspect all fuser rollers for radial lines, and if found replace the fuser.
- Verify the post charging unit is all the way to the right.
- Clean the paper path rollers with a hand wipe.
- Align a page showing the horizontal line defect with the face-up exit assembly. If the lines align with any of the sets of ribs on the assembly, replace the face-up exit assembly (see page 236).
- Align a page showing the horizontal line defect with both the input and the output sides of the fuser. If the lines align with any of the sets of ribs on the fuser, replace the fuser.

## Rain

(See also “Speckled print” and figure 197 on page 393.)

This defect appears as small specks of toner missing and is usually most visible with dark solid colors.

- Check the percentage of life remaining for the drum kit on the configuration page. Replace the drum kit if it is past its rated life.
- Check for contamination on the transfer drum and replace if necessary.
- Use the service and support CD to help troubleshoot print quality problems by printing blkftb31.ps on 11-by-17 inch sized paper or blk331.ps on A3-sized paper from tray 3. Type the following command at the DOS prompt to print the files:  
`copy <file name> lpt1`
- If a new imaging drum has been installed recently, this defect might appear during initial printing but should resolve itself. If it does not, replace the imaging drum.

## Speckled print

(See also “Rain” and figure 197 on page 393.)

Speckled print (or toner popping) defects are characterized by small speckles caused by missing toner.

- This can be caused by excess moisture in the print media. Prove the cause of this defect by printing with a properly stored ream of paper. Check that the media is stored in a dry area, and is not opened until ready to be used. Also, verify that the printer is not in a humid area.
- Verify that the green lever on the fuser is locked down. When the green lever is up, the toner does not fuse properly and toner can flake off the page.
- If the print is speckled on the second side of a duplexed page, use a heavier weight media (greater than 28 lb, 105 g/m<sup>2</sup>, bond).

## Smear print

- An undetected jam in the printer can smear print. Open and close the front door to allow the printer to clear the jam. If the problem persists, remove the transfer drum. Look between the transfer drum surface and the transfer drum handles for the piece of media. Remove any media, then reinstall the transfer drum.
- If the printer recently had a media jam, open and close the front door to complete a printer self-cleaning cycle.
- Verify that the green lever on the fuser is locked down. Also check that the fuser does not have toner build-up on the inputs. Clean any loose toner accumulated around the fuser.
- If the waste toner container is full, print might smear. Check the imaging drum life by printing a configuration page. If the drum kit is past its rated life, replace the drum kit.
- Perform a paper path test from the Service Mode Menu (see page 365) and look for obstructions in the paper path.
- Check that the media meets the specifications listed beginning on page 26. Rough media is most likely to show this defect. If media is heavier than 28 lb (105 g/m<sup>2</sup>) bond, you must select **Heavy Paper** as the paper type on the paper tab in the printer driver to ensure the correct finish on the media.
- Bent corners on the page can smear print. During the paper pick, particularly on rough media, the corner of the page might be bent. If the page retains the bend as it enters the fuser, print in the area of the bend might smear. Ensure that the paper is correctly loaded in the paper tray. If the defect persists, turn the paper stack over and end-for-end. Finally, try another media type.
- Ensure the transfer belt is installed correctly and is seated in its notches.

## Print on back of page (non-duplexed page)

- If the previous page printed was a prepunched media and there was an image in the location of the prepunched holes, then this toner is deposited on the back of the next page printed. Open and close the front door to complete a printer self-cleaning cycle.
- If smears appear on the back of the page, the transfer belt is dirty. Open and close the front door to complete a printer self-cleaning cycle.
- Print a configuration page to check the percentage of life remaining for the transfer kit. If the transfer kit is past its rated life, replace it.
- Ensure the transfer belt is installed correctly and is seated in its notches.
- Inspect the imaging drum for a jammed page. Remove the media.

## Poor fusing

Poor fusing is characterized by loose toner on the printed output. Unfused or poorly fused toner can be easily wiped off the page.

- Verify that the green lever on the fuser is locked down. Also check that the fuser does not have toner build-up in the input area. Clean any loose toner accumulated around the fuser.
- Verify that the media type is set correctly in the printer driver and the printer control panel.
- Check that the media is within the weight and smoothness specifications listed in the *HP LaserJet Printer Family Paper Specification Guide*.
- Check that the printer does not multi-feed. If more than one sheet enters the fuser, toner on the top sheet might not fuse.

## Ghosting

Ghosting appears as a latent image of previously printed material on the page with the currently printed text or graphic. It also can look like a repetitive defect, and is generally caused by a toner cartridge, transfer drum, imaging drum, or transfer belt problems.

- Open the right upper door and front door, and defeat the right upper cover detection interlock (see figure 182 on page 370). Place a piece of paper over the density sensor, remove and reinstall the imaging drum, and close the front door. As the engine begins calibrating, verify the red preconditioning exposure LED is lit.
- Print a configuration page (see page 361) and verify the consumable kits are not past their specified life.
- Print the following files from the service and support CD to help troubleshoot print quality problems.
  - Print optdtb31.ps on 11-by-17 inch sized paper or optda331.ps on A3-sized paper from tray 3 to troubleshoot the imaging drum.
  - Print glictb31.ps on 11-by-17 inch sized paper or glica331.ps on A3-sized paper from tray 3 to troubleshoot the toner cartridges.

Type the following command at the DOS prompt to print the files:  
`copy <file name> lpt1`

- If ghosting is occurring at a frequency of 150 mm, this defect could be a “hot fuser offset.” If the media does not meet the specifications for this printer, such as transparencies that are too thin, the fuser can lift the toner off of the page. The toner will stick to the fuser roller and be transferred to the next page, thus giving the appearance of a ghosted image. Verify the media meets the specifications in the *HP LaserJet Printer Family Paper Specification Guide*.



## Black, brown, or orange bands

(See figure 198 on page 394 for an example.)

Black, brown, or orange stripes (horizontal or vertical) across the page are caused by light leaking into the printer onto the imaging drum. This happens while the covers are off, such as when servicing the printer. Generally, the imaging drum will recover from exposure to room light, but the useful life of the imaging drum might be reduced. This defect is usually gradated along the page, with no clear starting or stopping point. If the black/brown/orange defect is not limited to a definite horizontal stripe, it might be necessary to replace the imaging drum. Imaging drum failure is also characterized by a black page.

---

### CAUTION

Ambient room light can permanently damage the imaging drum. Store the imaging drum in total darkness to protect the photosensitive coating.

---

### Note

If the entire page is black/brown/orange, this can indicate a high-voltage power supply problem.

---

## Background toner scatter

(See figure 199 on page 395 for an example.)

This defect appears as haze around text and graphics. It can occur with any color. Thoroughly clean the printer, and ensure the defect persists before troubleshooting it.

- Ensure media meets the specifications listed in the *HP LaserJet Printer Family Paper Specification Guide*. Some papers, especially recycled papers, have specks in them as manufactured. Compare printed and unprinted media for pre-existing specks.
- Replace any toner cartridge that is past its maximum life.
- Inspect the charging roller for contamination and replace, if necessary.

## Yellow or black streaks

- The imaging drum is past its maximum life. Print a configuration page and verify the imaging drum is not past its rated life. If it is, replace the drum kit.
- Oxide can build up on the post charging unit. Clean the post charging unit (see page 99).
- Look for any fibers or foreign objects that are in contact with the imaging drum. Clean or remove the objects as necessary.
- Replace the imaging drum if this problem persists.

## Mottled process colors or poor transfer

(See figure 200 on page 396 for an example.)

This defect appears as splotchy light areas in dark colors.

- Ensure media meets the specifications listed in the *HP LaserJet Printer Family Paper Specification Guide*. Rough, heavy, or moist media can cause this problem.
- Clean the transfer charger as shown page 101, and reseal the transfer belt. Oxide build-up on the transfer charger adversely affects how the printer transfers the developed image to the page. If the defect persists, replace the transfer kit.
- Verify the printer driver and printer control panel settings are correct for the media type.
- Print on different media to determine whether the problem is related to the media.
- Transparencies printed to the left (face-up) output bin can show this defect because the transparencies stick to each other. Try printing in smaller batches.

## Faint print

(See also “Mottled process colors or poor transfer” on page 408.)

A faint print image is a defect characterized by the image being developed at a reduced print density in any of the primary colors (CMYK).

- Ensure media meets the specifications listed in the *HP LaserJet Printer Family Paper Specification Guide*.
- The moisture content of the media is uneven or too high or some areas of media might reject toner. Try media from a different source or from an unopened ream of media. Also, make sure the printer is operating within the environmental specifications listed on page 21.
- Excessively rough paper can cause transfer problems. Change to a smooth xerographic paper.
- A toner cartridge might be running out of toner. Check for a TONER LOW REPLACE <color> or TONER OUT REPLACE <color> message on the printer control panel. Replace the toner cartridge indicated on the display.
- If the faint print, or missing print, is on the second side of a duplex page, the media might be too light for proper transfer. For media specifications, see page 28.
- Print a configuration page and verify the transfer kit is not past its maximum life. If necessary, replace the transfer kit.
- Verify media type set in the printer driver and printer control panel is correct.
- Ensure the transfer belt is installed correctly and is seated in its notches.

## Stray toner

(See figure 201 on page 397 for an example.)

- Check for toner build-up inside the printer, especially on horizontal surfaces. Use a hand wipe to remove any toner.
- Check the paper weight and smoothness. Rough paper can stick together, causing multi-feeds. Heavy media or the extra thickness of multiple sheets of paper can cause poor fusing, which deposits toner on the fuser rollers. This toner comes off on later pages as stray toner.
- If a media jam occurred recently, open and close the front door to complete a printer self-cleaning.
- If the stray toner is on the back of a simplex page, the reverse charge to clean the transfer belt is not being applied, or there is not enough bias to transfer the toner back to the transfer drum. Clean the printer by opening and closing the front door.
- Verify the cleaning roller rotates freely and is clean. Replace if necessary.
- Check the event log for fusing errors. If the fuser does not heat properly, the unfused toner accumulates around the fuser and is deposited on the page as stray toner.
- Clean the waste toner tray (see page 102).
- If contamination is made up of all four toner colors, verify that the imaging drum is not contaminated and that the waste toner cartridge is not too full (a full waste toner cartridge will make the imaging drum much heavier than a new imaging drum). If the cartridge is full, check the waste toner detection connections if no error message appeared on the printer control panel.

## Banding (less than 10 mm)

Banding is characterized by light or dark lines of color appearing perpendicular to the paper path direction. Banding can be caused by old maintenance units, by worn or damaged gears, and by consumables that are beyond their rated life. Also, some banding might appear at the beginning and at the end of the imaging drum life.

- Check the imaging drum life by printing a configuration page. Replace the drum if necessary.
- Remove the toner cartridges and inspect the drive gears for damage. Replace if necessary.
- Print the following files from the service and support CD to help troubleshoot print quality problems:
  - Print vcoltb31.ps on 11-by-17 inch sized paper or vcola331.ps on A3-sized paper from tray 3 to troubleshoot the toner cartridge banding.
  - Print grastb31.ps on 11-by-17 inch sized paper or grasa331.ps on A3-sized paper from tray 3 to troubleshoot imaging drum and main gear train banding.

Type the following command at the DOS prompt to print the files:

```
copy <file name> lpt1
```

## Banding (14 mm)

This defect is characterized by light or dark lines of color appearing repetitively at 195 mm (imaging drum repetitive defect). This can be caused by high or low humidity conditions at the beginning of the imaging drum life. The 14-mm band correlates to the unexposed area of the imaging drum sealed by the cleaner blade and sweeper strip (see figure 38 on page 140).

- Leave the printer in Power Save mode for 24 hours. The imaging drum will rotate periodically.
- Perform a sensor monitor test (see page 368) to get a reading from the temperature/humidity sensors.
- Print continuous configuration pages (10 to 100 pages) to see if the print quality improves.

## Overhead transparency defects

Overhead transparencies can display any of the image quality defects shown in figures 192 through 202 (pages 388 through 398). In addition, because transparencies are pliable while in the print path, they are subject to being marked by the media-handling components. Print from tray 1 to the left (face-up) output bin to reduce the chances of print defects on transparencies.

- Verify that the green lever on the fuser is locked down.
- Check that the transparencies meet the specifications listed on page 31.
- Make sure that **Transparency** is checked as the media type in the Paper tab in the printer driver. Also, make sure that the media input tray is correctly configured for transparencies.
- If transparencies show lines and creases in the media and/or the printed output, compare the defect against the repetitive defects ruler to help isolate the cause to a particular component (see page 420).
- If the transparencies have spots or smudges, reprint them being careful not to touch the surface of the media. Oil from your hands can contaminate transparencies, causing spots and smudges.
- Small-random-dark areas on the trailing edge of solid-fill pages might be caused by transparencies sticking together in the left (face-up) output bin. Try printing the job in smaller batches.
- Small random spots can be caused by dust on the transparency surface.

---

### Note

Allow transparencies to cool at least 30 seconds before handling them.

Transparencies created on the printer should not be used on reflective-type (portable) transparency projectors. Colors will project better on transmissive projectors.

---

## Dull or dark transparencies

If the transparency colors are dull or dark:

- Try printing the image on plain paper to verify the image is good.
- Ensure the transparencies meet the specifications for this printer (see page 31).
- Verify that the green lever on the fuser is locked down.

## Dark yellow print or contaminated print

(See figure 202 on page 398 for an example.)

This defect can be caused by toner being deposited on yellow areas. If the transfer kit is past its maximum life, colors might be contaminated.

- Try to avoid printing black or dark-colored images on pages preceding yellow or light-colored images.
- The cleaning roller might not be cleaning the transfer drum correctly. Open and close the front door of the printer to complete a cleaning cycle.
- Print a configuration page to check the life of the transfer kit. Replace the transfer kit if it is past its rated life.
- Print continuous configuration pages (10 to 20 pages) to see if the print quality improves.
- Print a configuration page to check the life of the drum kit. Replace the drum kit if it is past its rated life.
- If contamination is made up of all four toner colors, verify that the imaging drum is not contaminated and that the waste toner cartridge is not too full (a full waste toner cartridge will make the imaging drum much heavier than a new imaging drum). If the cartridge is full, check the waste toner detection connections if no error message appeared on the printer control panel.
- Use the service and support CD to help troubleshoot print quality problems. Print clean.ps (found on the CD) on letter- or A4-sized paper from tray 2 and on 11-by-17 inch or A3-sized paper from tray 3 to troubleshoot the cleaning and contamination problems. Type the following command at the DOS prompt to print the files:  
`copy <file name> lpt1`

## Color balance adjustment

---

### CAUTION

---

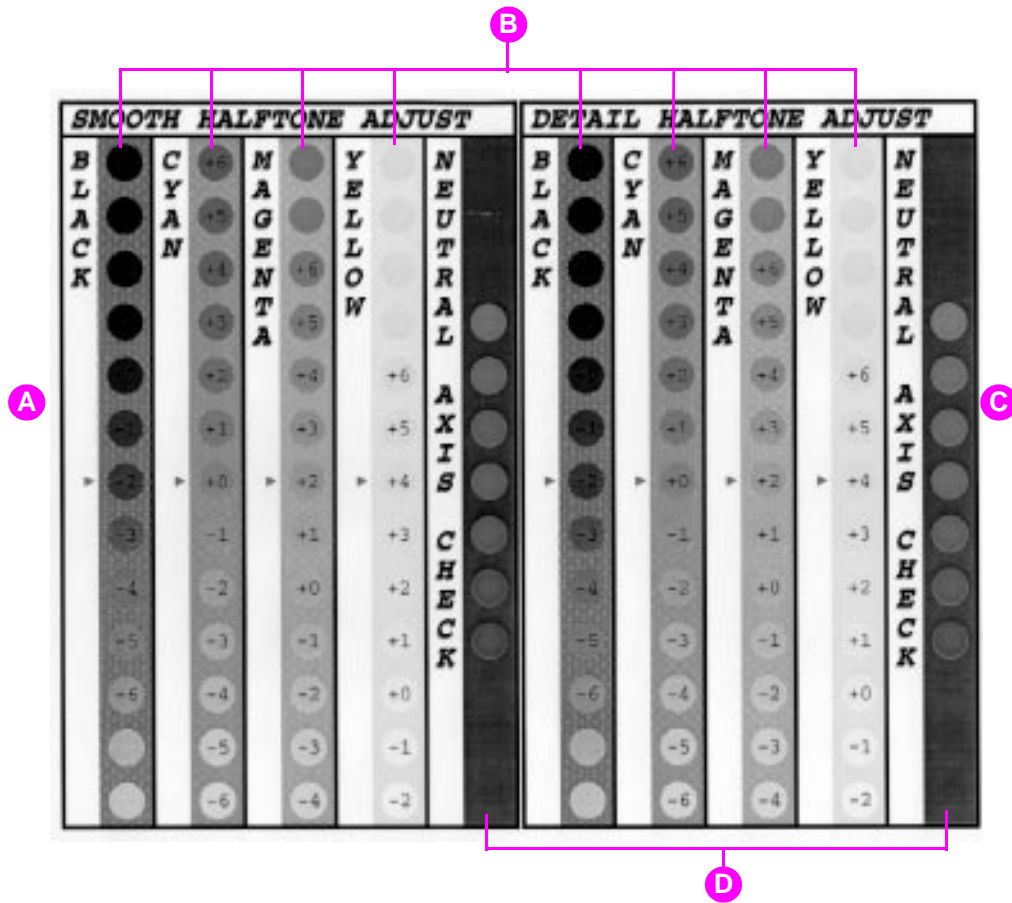
Adjusting the color balance changes the printer's calibration. Because this procedure adjusts parameters within the printer hardware, it will affect all print jobs.

The printer automatically recalibrates the color settings. However, you can adjust the color manually from the default settings by changing the densities of the four toners (black, cyan, magenta, and yellow). Changing the Detail Half-tone Adjust and Smooth Half-tone Adjust allow you to independently adjust the color of objects on a page that use the smooth and detail half-tones (such as text and graphics). Any settings you change remain in effect until you change them again or restore the factory defaults.

Do not perform the color balance adjustment procedure until all of the following troubleshooting methods have been completed:

- Experiment with the printer driver and application settings to adjust the color output. For more information on application settings, see the online help.
- Clean the density sensor (see page 100).
- Complete the troubleshooting solutions earlier in this chapter for the color printing problem you are experiencing.





**Figure 203. Color adjust page**

- A** Smooth Half-tone Adjust section
- B** Color ramps
- C** Detail Half-tone Adjust section
- D** Neutral axis

**1 Print the color adjust page.**

- a Press **GO** and **- VALUE +** at the same time. **COLOR ADJUST MENU** appears on the printer control panel display.
- b Press **ITEM** until **PRINT TEST PAGE** appears on the display.
- c Press **SELECT** to print the color adjust page.
- d Press **GO** to exit the Color Adjust Menu.

The color adjust page allows you to adjust the printer's two half-tone screens for each of the four colors (black, cyan, magenta, and yellow) for a total of eight adjustments. Make these adjustments after examining the color adjust page.

The color adjust page consists of two sections: the Detail Half-tone Adjust section and the Smooth Half-tone Adjust section. Each section shows the adjustment ramps for black, cyan, magenta, and yellow and a neutral axis check ramp, which can be used to verify the adjustment after the correction values have been entered for each of the primary colors. Figure 203 is an example of the color adjust page.

**2 Note the numbers beside the red arrows for later reference.**

The color adjust page indicates the last set of saved color settings with a red arrow next to the saved setting. The default for each color is 0 (other possible settings include -6 through 6).

**3 Determine the color adjustment numbers for each color in the color ramps.**

- a Examine the color adjust page from a distance of 6 ft (approximately 2 m).
- b Find the circle of each color that most closely matches the background color. It might be necessary to squint slightly to match the colors.
- c Record the number in the circle.

**4 Enter the color adjustment numbers in the printer control panel.**

- a Press **GO** and **- VALUE +** at the same time. **COLOR ADJUST MENU** appears on the display.
- b Press **ITEM** until the option you want appears on the display. The options are listed below:
  - **BLACK SMOOTH VALUE =**      ● **CYAN SMOOTH VALUE =**
  - **MAGENTA SMOOTH VALUE =**      ● **YELLOW SMOOTH VALUE =**
  - **BLACK DETAIL VALUE =**      ● **CYAN DETAIL VALUE =**
  - **MAGENTA DETAIL VALUE =**      ● **YELLOW DETAIL VALUE =**
- c Press **- VALUE +** until the number recorded in step 3c appears on the display.
- d Press **SELECT** to enter the number into the printer memory. An asterisk (\*) appears to the right of the selection.
- e Repeat steps 4a through 4d to adjust the color screens, as necessary.

**5 Reprint the color adjust page.**

**6 Examine the new color adjust test page and verify that the color adjustment is correct.**

- Verify that each of the color ramps (black, cyan, magenta, and yellow) matches the background for each color and has a red arrow next to the circle. If another circle matches the background more closely, return to step 4 to reset the values on the printer control panel to the number shown in that circle.
- Verify that the circles in the neutral axis areas of the color adjust test page are neutral gray (gray without a color tint), and then verify that one of the circles in the ramp is a color very close to the background. If the circles are not neutral gray, additional corrections to cyan, magenta, or yellow might be necessary. If there is an overall tint of color in the circles, make the adjustments suggested by the following table. However, the most accurate correction is determined by the circles in the individual black, cyan, magenta, and yellow ramps.

**Table 44. Neutral axis adjustments**

<b>Overall color of circles</b>	<b>Correction if all circles are darker than background</b>	<b>Correction if all circles are lighter than background</b>
Cyan tint	Reduce cyan	Increase magenta and yellow
Magenta tint	Reduce magenta	Increase cyan and yellow
Yellow tint	Reduce yellow	Increase magenta and cyan
Green tint	Reduce yellow and cyan	Increase magenta
Red tint	Reduce yellow and magenta	Increase cyan
Purple or blue tint	Reduce cyan and magenta	Increase yellow

For example, if the circles in the neutral axes show a green tint and the circle appears lighter than the background, the magenta ramp should be examined closely to determine if magenta should be increased.

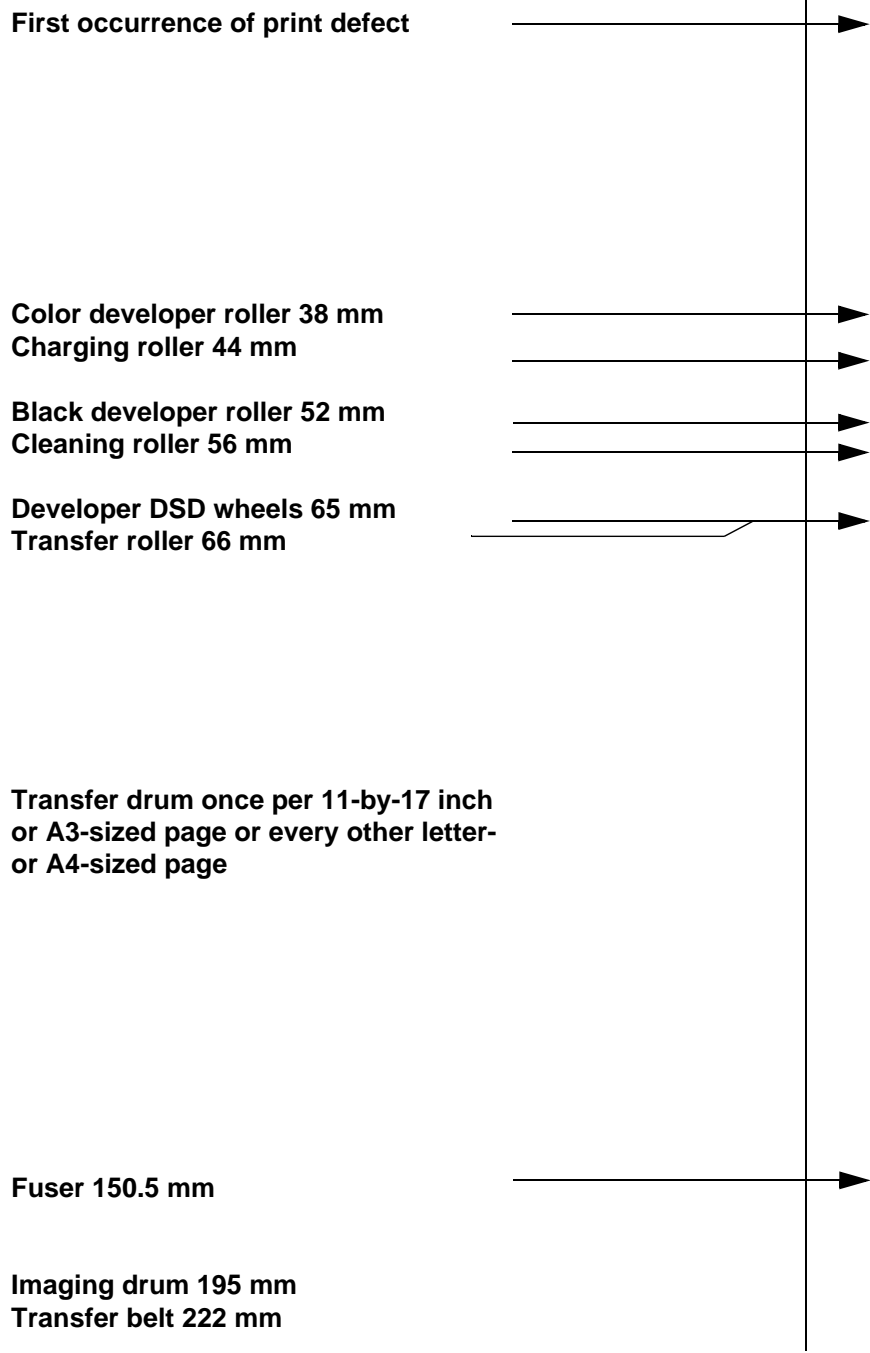
**Note**

If the color settings are less accurate when you finish the color adjustment than when you started, reset all color values to 0 (zero) in the printer control panel and try the adjustment again.

## Repetitive defects troubleshooting

Repetitive defects are defects that occur in the same vertical position on the page, but not necessarily on each page. Most repetitive defects are caused by problems with one of the following:

- developer roller (38 mm)
- charging roller (44 mm)
- cleaning roller (56 mm)
- developer DSD wheels (65 mm)
- transfer roller (66 mm)
- transfer drum (once per 11-by-17 inch or A3-sized page, or every other letter- or A4-sized page)
- fuser (150.5 mm)
- imaging drum (195 mm)
- transfer belt (222 mm)



**Figure 204.** Repetitive defect ruler

## **Color developer roller**

**Symptoms:** Print defect occurring every 38 mm.

**Cause:** Dirty or damaged developer roller.

**Actions:** Replace the toner cartridge.

## **Charging roller**

**Symptoms:** Print defect occurring every 44 mm.

**Cause:** Dirty or damaged charging roller.

**Actions:** Replace the toner cartridge.

## **Black developer roller**

**Symptoms:** Print defect occurring every 38 mm.

**Cause:** Dirty or damaged developer roller.

**Actions:** Replace the toner cartridge.

## **Cleaning roller**

**Symptoms:** Print defects occurring every 56 mm.

**Cause:** Dirty or damaged cleaning roller.

**Actions:** Clean the cleaning roller with a hand wipe. If cleaning does not resolve the defect, replace the cleaning roller.

## **Developer DSD wheels**

**Symptoms:** Print defect occurring every 65 mm.

**Cause:** Dirty or damaged developer DSD wheels. These wheels are located on the outer ends of the color toner cartridge and appear as a black bushing.

**Actions:** Replace the toner cartridge of the color producing the repetitive defect.

## Transfer roller

**Symptoms:** Print defect occurring every 66 mm.

**Cause:** Dirty or damaged transfer roller.

**Actions:** Clean the transfer roller with isopropyl alcohol and a hand wipe. If cleaning does not resolve the defect, replace the transfer belt.

## Transfer drum

**Symptoms:** Print defect occurring once per page on 11-by 17 inch- or A3-sized media, or on every other letter- or A4- sized page.

**Cause:** Dirty or damaged transfer drum.

**Actions:** Clean the transfer drum (see below). If the defect is not resolved by cleaning, replace the transfer drum.

## Cleaning the transfer drum

Many, but not all, repetitive defects can be removed using the following procedures. Defects that appear as light spots in dark areas of print are more likely to be corrected by this procedure than dark spots in unprinted areas.

---

### CAUTION

---

If the procedures are performed incorrectly or without proper care, the transfer drum can be permanently damaged.

This procedure requires the following items:

- a print sample showing the repetitive defect
- a clean, flat surface to work on
- isopropyl alcohol
- a hand wipe

---

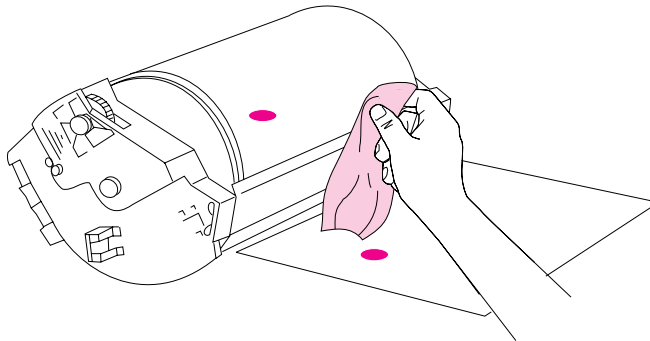
### CAUTION

---

You can also use a dry, clean, soft, lint-free cloth, such as cheesecloth, to clean the transfer drum. To prevent scratches on the drum, do not use any paper products (such as tissue or paper towels) to clean the drum.



- 1 Turn the printer off and open the front door.
- 2 Press the button and swing the lower lever to the right.
- 3 Open the right upper door, and remove the transfer drum.
- 4 Using the print sample as a reference, inspect the transfer drum for a spot or speck that might be causing the repetitive defects.



**Figure 205.** Cleaning the transfer drum

---

**CAUTION**

---

Do not clean the transfer drum using force. Do not use any water-based cleaners or excessive alcohol. These actions can permanently damage the transfer drum.

- 5 Gently rub the spot or speck with a hand wipe.

---

**Note**

---

If necessary, use isopropyl alcohol on a hand wipe to clean the transfer drum. If you use isopropyl alcohol, print 50 to 100 pages to clean any residual isopropyl alcohol from the drum.

- 6 Reinstall the transfer drum.
- 7 Swing the lower lever to the left making sure it clicks into place.
- 8 Close the right upper and front doors, and turn the printer on.
- 9 Reprint the print job. If cleaning does not eliminate the repetitive defect, replace the transfer drum.

## Fuser

**Symptoms:** Print defects occurring at about 150.5 mm. The defects will be most visible on overhead transparencies.

**Cause:** Defect on the upper fuser roller.

**Actions:**

- 1 Power the printer off, allow 30 minutes for the fuser to cool, and remove the fuser.
- 2 Turn the fuser gears and inspect the surface of the upper fusing roller. If the roller has surface defects, replace the fuser assembly.

## Imaging drum

**Symptoms:** Print defects occurring every 195 mm.

**Causes:**

- Damage such as scratches or dents on the imaging drum. These usually appear as dark or light marks on the page.
- Paper dust adhering to the imaging drum. These usually appear as white marks in the dark printed areas of the page.
- Exposure of portions of the imaging drum to light. This causes dark sections in the printed output. The life of the imaging drum is shortened by exposure to strong light.

**Actions:**

- Print at least four configuration pages to determine if the defect repeats in the same vertical orientation.
- Inspect the imaging drum for scratches, dents, or other damage. Replace if needed.
- If the problem is dust, remove the dust with 70% isopropyl alcohol applied with a hand wipe. Try this *only* if the print defect is unacceptable and the only other alternative is replacing the imaging drum.
- Defects caused by exposure to light might clear up over time. If severe, replace the imaging drum.

---

**CAUTION**

---

Do not expose the imaging drum to direct sunlight, and be careful not to scratch or get fingerprints on the drum surface during cleaning.

## **Transfer belt**

**Symptoms:** Print defects occurring every 222 mm.

**Cause:** Defects on the transfer belt surface.

**Actions:** Remove the transfer belt and inspect the entire belt surface.  
Use the transfer belt gears to rotate the belt throughout its travel.

## 2,000-sheet input unit troubleshooting

This section provides a systematic approach to identifying the causes of malfunctions and errors in the 2,000-sheet input unit.

### Ways to troubleshoot the unit

In general, there are three possible sources of malfunction:

- the 2,000-sheet input unit itself
- printer electronics
- C-link cable that connects the unit and the printer

### Begin troubleshooting

- 1 Print or display the error log. Evaluate the error log for any specific error trends in the last 10,000 printed pages.
- 2 Print a configuration page to verify the proper installation of the paper-handling accessories.
  - If any of the installed accessories are not shown on the configuration page, check the corresponding cable connections.
  - Verify that the C-link cable is correctly connected and functional.
  - Verify that DC power is available to the paper-handling accessories.
- 3 If necessary, use one of the following diagnostic tools to isolate the problem:
  - **Status LED on the front of the unit** — Indicates the status of the unit (see page 427).
  - **Service LED inside the back cover** — The pattern of flashing (long and short) isolates the problem (see page 428).
  - **Standalone running test** — You can use this to test whether the unit itself is functioning properly (see page 430).
  - **Motor test** — Lets you check the motor to see if it is working properly (see page 431).
  - **Sensor tests** — Lets you check the sensors to see if they are working properly (see page 432).

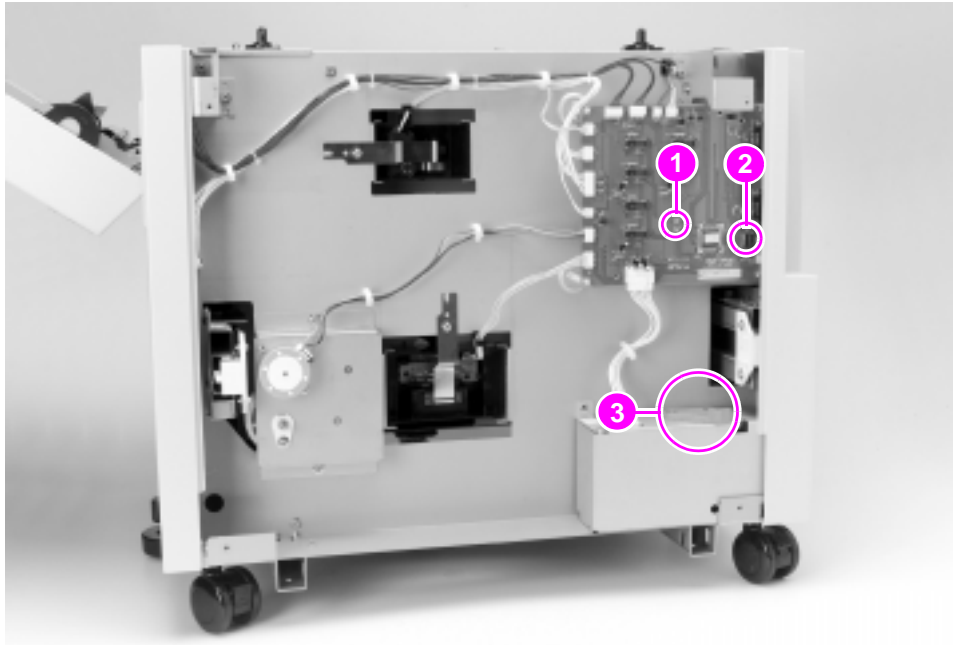
## Status LED descriptions

The status light on the front of the unit provides status information.

**Table 45. Status LED on the 2,000-sheet input unit**

State	Description	Resolution
Solid green	The unit is on and ready.	None required.
Solid amber	The unit is experiencing a hardware malfunction.	Isolate the problem using one of the other procedures described in this section.
Flashing amber	The unit has a media jam or a page needs to be removed from the 2,000-sheet input unit, even if the page is not jammed.	Clear the jam or remove the page.
	The VTU might be open.	Close the door.
Off	The printer might be in Power Save mode.	Press <b>Go</b> .
	The unit is not receiving power.	Check the power supply and the power cables.

## Service LED descriptions



**Figure 206.** Rear view of 2,000-sheet input unit

- 1 Service LEDs
- 2 DIP switches
- 3 Power supply

---

**Note** Be sure to turn the power supply off and set all DIP switches to the off position when you finish the test or the unit will not work.

*The DIP switch is ON if it is to the right. The DIP switch is OFF if it is to the left.*

---

**Note** To go from one test to another or to change the DIP switch settings, turn the power supply on the 2,000-sheet input unit to operational mode. Reset the DIP switches on the controller PCA, and then switch the power supply back to diagnostic mode to enable the new diagnostic test.

---

## Service LED interpretation

If the 2,000-sheet input unit is working properly, it will pick up paper from tray 4 and expel it; the bottom service LED will flash regularly every 0.5 seconds.

**Table 46. Patterns of LED flashing (2-second pause between each pattern)**

Long (1 sec)	Short (0.3 sec)	Description	Recommended action
3	1	Lifter malfunction	Verify that the tray lifts freely by lifting it by hand. Verify that the paper size plates are installed correctly (in the same corresponding slots) and are not bent. If neither of these is the problem, replace tray 4.
2	1	Registration sensor delay jam	The media does not reach the sensor. Open the VTU door and remove the media. Replace the paper feed (VTU) assembly or the paper pick-up assembly.
2	2	Registration sensor stationary jam/initial jam	Open the VTU door and remove the media. Check the sensors and replace the corresponding field replaceable unit.
2	3	Jam sensor delay jam	The media did not reach the sensor. Open the VTU door and remove the media. Replace the paper feed (VTU) assembly or the paper pick-up assembly.
2	4	Jam sensor stationary jam/initial jam	Open the VTU door and remove the media.
1	1	VTU door is open	Close the door.
1	2	Tray 4 is open	Close the tray.
		Wrong paper size loaded	Load the correct size of paper or check sensors.
1	3	No paper in tray 4	Load paper or check sensors.

**Note** If the LEDs do not come on, replace the paper deck PCA or the power supply.

## DIP switch settings

The following table shows the position of the DIP switches to run each of the 2,000-sheet input unit diagnostic tests.

**Table 47. DIP switch settings for troubleshooting test procedures**

DIP switch	Normal setting	Motor test	Standalone running test	Sensor test
1	Off	On	On	Off
2	Off	On	Off	Off
3	Off	Off	Off	On
4	Off	On	On	On

## Standalone running test

This test verifies that the 2,000-sheet input unit is functioning properly. For this test, use the service LEDs. (See page 429 for an interpretation of the service LED patterns.)

### CAUTION

To prevent excessive media jams during this test, feed only 6 to 8 pages.

- 1 Ensure that paper is in the tray.
- 2 Set the DIP switches on the 2,000-sheet input unit's controller PCA for the standalone running test. (See page 430 for an explanation of the settings.)
- 3 Use the switch that is located on the unit's power supply to switch to diagnostic mode.
  - If the unit does not work, there is no paper movement and the lower service LED flashes in a pattern that indicates the problem. (See page 429 for an interpretation of the service LED patterns.)
- 4 To stop the test, turn the power supply switch back to operational mode and set the DIP switches on the controller PCA to the off position. Open the VTU and remove any media from the paper path.

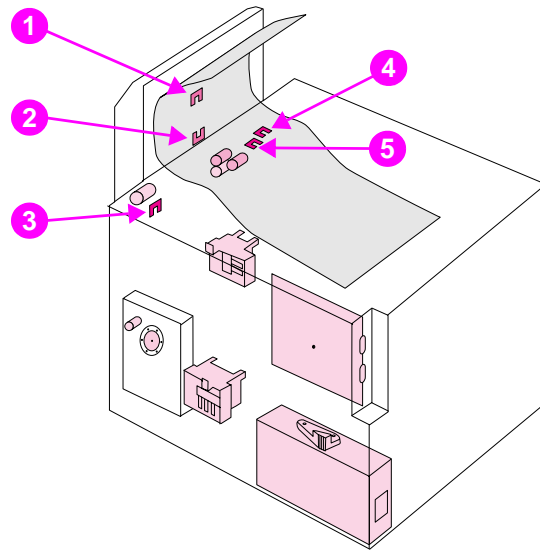


## Motor test

This test verifies that the three motors on the 2,000-sheet input unit are functioning properly.

- 1 Remove the back cover from the 2,000-sheet input unit (see page 273).
- 2 Open tray 4 and the vertical transfer unit (VTU).
- 3 Set the DIP switches on the 2,000-sheet input unit's controller PCA for the motor test. (See page 430 for an explanation of the settings.)
- 4 Use the switch that is located on the unit's power supply to switch to diagnostic mode.
  - If the motors are working properly, they rotate continuously.
  - If the motors do not rotate, replace the corresponding field replaceable unit: either the paper pick-up assembly, the VTU, or the paper deck drive assembly.
- 5 To stop the test, turn the switch on the power supply back to operational mode and reset the DIP switches on the controller PCA to the off position.

## Sensor test



**Figure 207.** Location of sensors in the 2,000-sheet input unit

- 1 Paper exit sensor (PS32)
- 2 Paper entry sensor (PS31)
- 3 VTU closed sensor (PS35)
- 4 Paper tray raised sensor (PS34)
- 5 Paper tray empty sensor (PS33)

- 1** Set the DIP switches on the 2,000-sheet input unit's controller PCA for the sensor test. (See page 430 for an explanation of the settings.)
- 2** For each paper sensor:
  - a** Open the paper tray and the VTU on the 2,000-sheet input unit.
  - b** Remove the metal spring that holds the sensor unit in place (secured by 1 screw) (see figure 153 callout 2 and figure 154 callout 2).
  - c** Pull out the sensor unit.
- 3** Use the switch that is located on the unit's power supply to switch to diagnostic mode.
- 4** Manually activate the sensor.
  - When you activate the sensor, the bottom service LED on the controller PCA comes on. When you release the sensor, the LED goes off.
  - If the LED does not come on, there is a problem with the sensor. Replace the corresponding field replaceable unit.
- 5** To stop the test, turn the power supply switch back to operational mode and set the DIP switches on the controller PCA to the off position.

## Multi-bin mailbox troubleshooting

The multi-bin mailbox standalone diagnostic tool is a troubleshooting aid that verifies how the multi-bin mailbox functions alone. The tests are designed to be used without C-link commands from the EPH controller on the printer.

### Switching the multi-bin mailbox to test mode

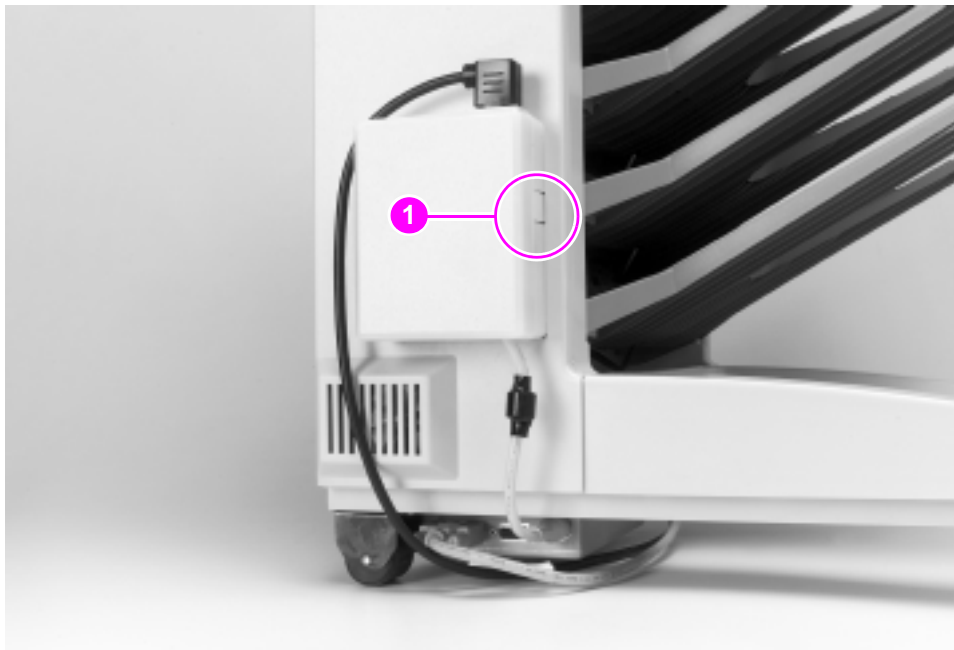
- 1 Turn the printer off and remove the multi-bin mailbox from the printer.
- 2 Move the multi-bin mailbox power supply switch to test mode (callout 1).

---

#### Note

Reset the power supply switch to normal mode when you finish running diagnostic tests; otherwise, the multi-bin mailbox will not work.

---



**Figure 208.** Multi-bin mailbox power supply test mode switch

## Power-up sequence test

- 1 Push in and hold the multi-bin mailbox interlock switch. The multi-bin mailbox begins a power-up test.
  - All the motors in the multi-bin mailbox start working, and the delivery head assembly moves up and down the multi-bin mailbox twice, scanning to determine that all the output paper bins are properly installed.
  - At the end of the power-up test, the flipper motor remains working and waiting for feeding paper.
- 2 Check the user status LED on the front and the three service LEDs on the back side of the multi-bin mailbox. If the power-up test is successful, the user status LED remains green and the middle service LED shows solid red. The other two service LEDs remain off.
- 3 If the service LEDs are blinking in a pattern, indicating an error code, a problem exists (table 48 on page 436 lists the error codes indicated by the blinking pattern).

## Paper path test

### Note

Use only supported media types for the paper path test.






- 1 Manually feed paper through the input paper guide.
  - The paper passes across the flipper assembly and moves down to the bottom paper bin through the transport belt system via the delivery head assembly.
- 2 Feed several pages, one at a time, through the input paper guide. If the paper path test is successful, reinstall the multi-bin mailbox.
- 3 If a problem exists, the service LEDs blink in a pattern, indicating an error code (table 48 on page 436 lists the error codes indicated by the blinking pattern).

## Multi-bin mailbox LED descriptions













The multi-bin mailbox features a user status LED and three service LEDs.

- The user status LED is a single LED that is located on the front cover of the multi-bin mailbox at the top. The user LED provides information about the power-on status and about the attachment to and alignment of the accessory with the printer.
- The three service LEDs are near the center of the multi-bin mailbox back cover. The service LEDs blink independently of each other, indicating the status of the multi-bin mailbox.













## LED status interpretation

-  Solid green
-  Solid red
-  Blinking red
-  Solid amber
-  Blinking amber
-  Blank

















**Table 48. Status LEDs on the multi-bin mailbox**

User LED	Service LEDs	Message description	Recommended action
	  	<b>Multi-bin mailbox ready</b> The multi-bin mailbox was successfully connected and initialized by the printer.	● No action required.
	  	<b>Power Save mode</b> The multi-bin mailbox is in Power Save mode.	● No action required.
	  	<b>Test mode</b> The multi-bin mailbox is in test mode.	● Run the power-on test. ● Run the paper path test.

**Table 48. Status LEDs on the multi-bin mailbox (continued)**

User LED	Service LEDs	Message description	Recommended action
		<b>Multi-bin mailbox unlatched from the printer</b> The multi-bin mailbox is not properly attached to the printer.	<ul style="list-style-type: none"> <li>● Check alignment of the multi-bin mailbox.</li> <li>● Check the attachment clips.</li> <li>● Check adjustable casters.</li> <li>● Check the interlock switch.</li> </ul>
		<b>Flipper error</b> During the flipper calibration, an abnormal reference voltage was encountered.	<ul style="list-style-type: none"> <li>● Check for media jam in the flipper assembly area.</li> <li>● Check cable connections.</li> <li>● Replace flipper assembly.</li> <li>● Replace the multi-bin mailbox controller PCA.</li> </ul>
		<b>Face-up bin is too full</b> The face-up bin is too full.	<ul style="list-style-type: none"> <li>● Remove media from the face-up bin.</li> <li>● Check for jammed sensor flag.</li> <li>● Replace the flipper assembly.</li> <li>● Check for proper cable connection.</li> </ul>
		<b>Jam in flipper area</b> Time-out condition at the entry area.	<ul style="list-style-type: none"> <li>● Open jam access door and check for media jam or out-of- place flipper assembly shaft.</li> <li>● Check for jammed paper sensor.</li> <li>● Replace the flipper assembly.</li> <li>● Replace the multi-bin mailbox controller PCA.</li> </ul>
		<b>Jam in belt</b> Time-out condition in the transport belt.	<ul style="list-style-type: none"> <li>● Check for media jam in the transport belt system/delivery head assembly.</li> <li>● Ensure free movement of the transport belt (both belts).</li> <li>● Ensure that belts are parallel in the transport belt system.</li> <li>● Check that the metal tape is in place and in good condition.</li> <li>● Replace the transport belt motor.</li> <li>● Replace the multi-bin mailbox controller PCA.</li> <li>● Replace the delivery head assembly.</li> </ul>
		<b>Sliders problem at the head assembly</b> The sliders do not activate the slider photosensor.	<ul style="list-style-type: none"> <li>● Check for media jam in the delivery head assembly.</li> <li>● Check that all paper bins are seated correctly.</li> <li>● Replace the delivery head assembly.</li> </ul>

**Table 48. Status LEDs on the multi-bin mailbox (continued)**

User LED	Service LEDs	Message description	Recommended action
	  	<b>External memory error</b> Multi-bin mailbox nonvolatile RAM (NVRAM) damaged.	<ul style="list-style-type: none"> <li>● Replace the multi-bin mailbox controller PCA.</li> </ul>
	  	<b>Jam in delivery head assembly</b> Time-out condition in the PSExit1 sensor.	<ul style="list-style-type: none"> <li>● Check for media jam in the delivery head assembly.</li> <li>● Check for free movement in both PSExit1 and PSExit2 sensors on the delivery head assembly.</li> <li>● Check that the fingers are over the ejector rollers on the delivery head assembly.</li> <li>● Replace the flat ribbon cable that connects to the delivery head assembly.</li> <li>● Replace the delivery head assembly.</li> <li>● Replace the multi-bin mailbox controller PCA.</li> </ul>
	  	<b>Jam in the delivery head position system</b> The elevator motor detects an invalid window when scanning.	<ul style="list-style-type: none"> <li>● Check that the blind cover and scan bar are installed properly.</li> <li>● Check for media jam in the delivery head assembly.</li> <li>● Check for free movement of the delivery head assembly.</li> <li>● Check that all paper bins are seated correctly.</li> <li>● Check that paper bins and blind cover are not broken.</li> <li>● Replace the delivery head motor.</li> <li>● Replace the delivery head assembly.</li> <li>● Replace the multi-bin mailbox controller PCA.</li> </ul>
	  	<b>Wrong page request</b> Page request received with invalid output bin or invalid paper size information.	<ul style="list-style-type: none"> <li>● Check the bin destination.</li> <li>● Check the paper size configuration.</li> <li>● Power up the system.</li> </ul>



## Communications troubleshooting

### HP network interface support

Unless you are experienced with the particular network under repair, seek the help of a qualified network professional before changing any network configuration settings.

If the printer is configured with an HP network interface card (such as an HP JetDirect product), the Response Center is available to help with any problems. Additional information is available from the *HP JetDirect Printer Software Installation Guide* (see page 448 for ordering information).

---

**CAUTION**

---

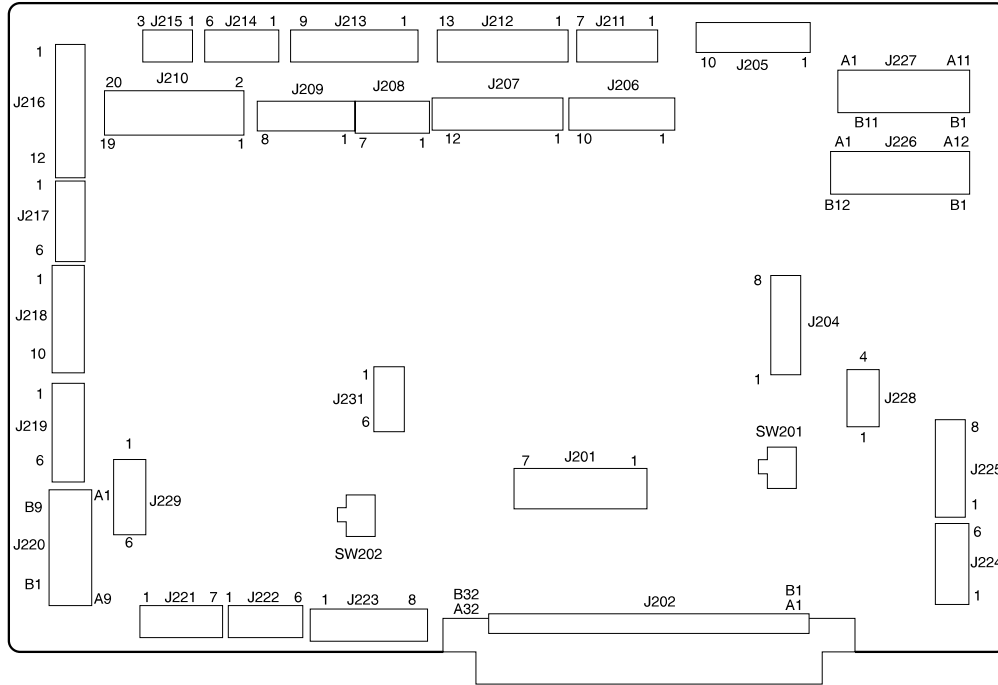
Network interface cards are not directly interchangeable. Do not exchange interface cards without understanding and performing the configuration process for each of the exchanged cards and the network.

### Third-party network interface support

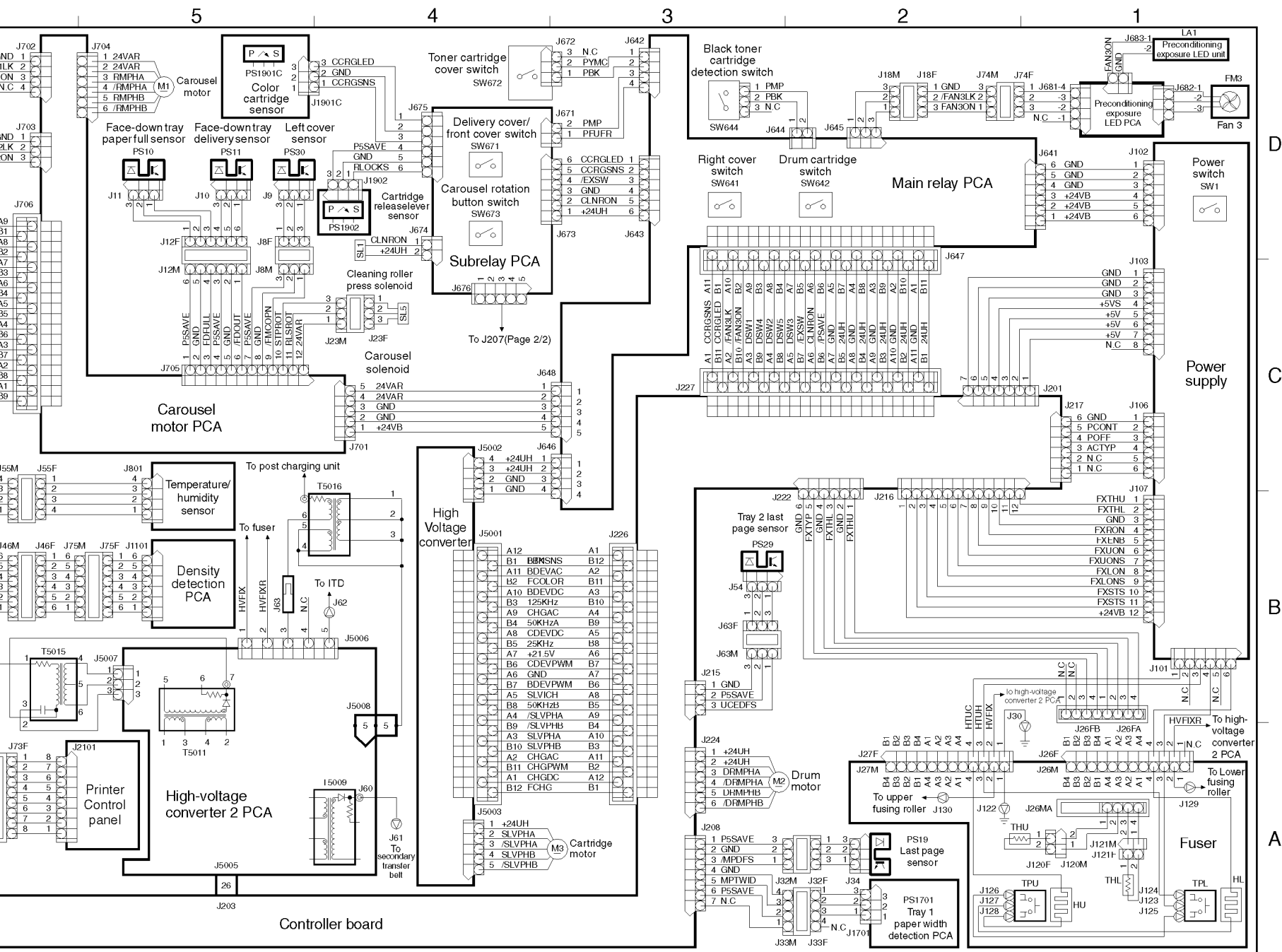
If a problem is associated with a third-party network interface card, refer to the documentation that came with the card and the vendor support organization for help in troubleshooting.

## Diagrams

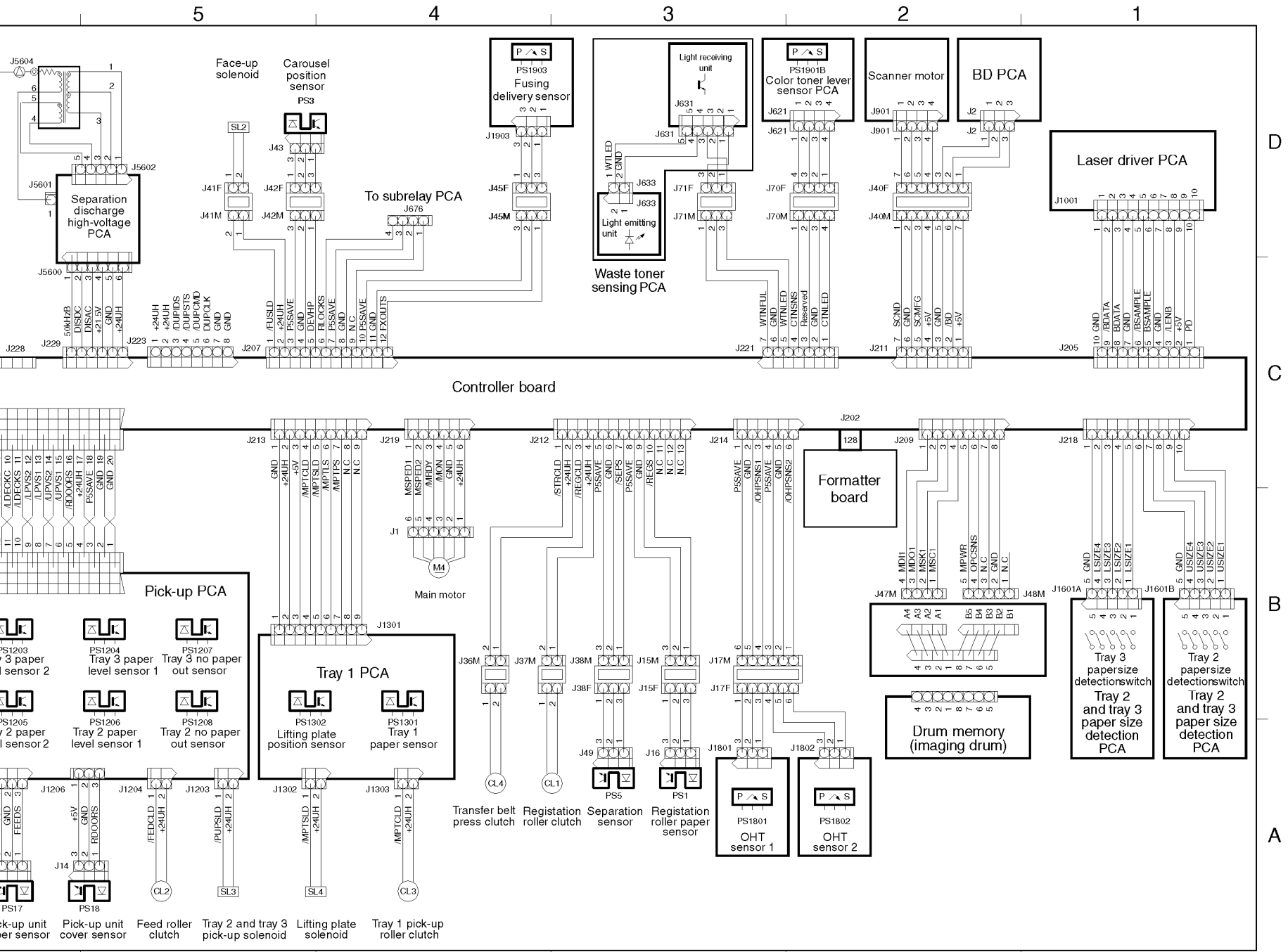
This section contains general circuit (wiring) diagrams.



**Figure 209.** Connectors on the controller board



Printer circuit diagram (1 of 2)



Printer circuit diagram (2 of 2)

# 8 Parts and diagrams

## Chapter contents

Overview . . . . .	445
Ordering parts . . . . .	445
Consumables, options, and accessories . . . . .	445
Miscellaneous parts . . . . .	448
Illustrations and parts lists . . . . .	449
Major assembly locations . . . . .	450
Printer covers and doors . . . . .	452
Internal cover assembly . . . . .	458
Internal components . . . . .	460
Drum/cartridge drive assembly . . . . .	472
Delivery drive assembly . . . . .	473
Tray 3 assembly . . . . .	474
Tray 2 assembly . . . . .	475
Paper pick-up assembly . . . . .	476
Registration frame assembly . . . . .	480
Registration roller assembly . . . . .	481
Feeder assembly . . . . .	482
Tray 1 pick-up assembly . . . . .	483
Tray 1 assembly . . . . .	484
Delivery assembly . . . . .	485
Delivery cover assembly . . . . .	486
Transfer belt assembly . . . . .	487
Fuser assembly . . . . .	488
PCA assembly location diagram . . . . .	491

2,000-sheet input unit covers and doors . . . . .	492
Multi-bin mailbox components . . . . .	496
Numerical parts list . . . . .	502
Alphabetical parts list . . . . .	513

## Overview

The figures in this chapter illustrate the major assemblies in the printer and their component parts. A table (materials list) follows each exploded assembly diagram. Each table lists a reference number to the illustration, part number, quantity, and description for each part.

---

**Note**

When looking for a part number, pay careful attention to the voltage listed in the description column (if there is one) to ensure that the part number selected is for the correct printer model.

---

## Ordering parts

All standard part numbers are stocked and can be ordered from Support Materials Organization (SMO) or Support Materials Europe (SME). For information on contacting SMO or SME, see page 49.

---

**Note**

Parts that have no reference number or part number are not field replaceable and cannot be ordered.

---

## Consumables, options, and accessories

The items listed in table 49 are available through your local authorized HP dealer. To find a dealer near you (or if your local dealer is temporarily out of stock), call the HP Customer Information Center at (1) (800) 752-0900.

---

**Note**

Order two sets of DIMMs if upgrading the printer memory; order one set of DIMMs if replacing memory.

---

**Table 49. Options, accessories, and consumables**

<b>Part number</b>	<b>Description</b>
<b>Memory</b>	
C2986-60001	Hard disk, internal
C4140A	4-MB synchronous DIMM <b>NOTE:</b> For all DIMM products, you must install DRAM DIMMs in synchronized pairs—for example, two 4-MB DIMMs.
C4141A	8-MB synchronous DIMM
C4142A	16-MB synchronous DIMM
C4143A	32-MB synchronous DIMM
C3913A	64-MB synchronous DIMM
<b>EIO accessories</b>	
C2985A	EIO hard disk
J3110A	Ethernet 10Base-T
J3111A	Ethernet combo (10Base-T, BNC, and LocalTalk)
J3112A	Token Ring
J3113A	10/100Base-TX
<b>Paper handling accessories</b>	
C4782-60501	Duplexer (product number C4782A)
C4782-69501	Exchange duplexer
C4785-60500	Multi-bin mailbox (product number C4785A) <b>NOTE:</b> You must have a 2,000-sheet input unit in order to install a multi-bin mailbox.
C4785A-69501	Exchange multi-bin mailbox



**Table 49. Options, accessories, and consumables (continued)**

<b>Part number</b>	<b>Description</b>
<b>Consumables</b>	
C4149A	Black toner cartridge
C4150A	Cyan toner cartridge
C4151A	Magenta toner cartridge
C4152A	Yellow toner cartridge
C4153A	Drum kit Imaging drum 2 air filters Hand wipe
C4154A	Transfer kit Transfer drum Transfer belt Cleaning roller Charcoal filter Hand wipe
C4155A	110-volt fuser kit Fuser 6 paper rollers Hand wipe
C4156A	220-volt fuser kit Fuser 6 paper rollers Hand wipe
<b>Cables</b>	
92215S	Macintosh DIN-8 printer cable
92215N	HP LocalTalk cable kit
C2946A	IEEE-1284 compliant parallel cable of 3 m (approximately 10 ft) with 25-pin male/micro 36-pin male "C" size connector
C3763-60502	C-link cable (from formatter board to the 2,000-sheet input unit)
<b>Media</b>	
C2934A	HP Color LaserJet transparencies (letter-sized), 50 sheets
C2936A	HP Color LaserJet transparencies (A4-sized), 50 sheets
C4179A	HP Color LaserJet soft gloss paper (letter-sized), 200 sheets
C4179B	HP Color LaserJet soft gloss paper (A4-sized), 200 sheets

**Table 49. Options, accessories, and consumables (continued)**

<b>Part number</b>	<b>Description</b>
<b>Reference materials</b>	
5021-8956	<i>HP LaserJet Printer Family Paper Specification Guide</i>
5021-0337	PCL/PJL Technical Reference Package
5091-6456	<i>HP Peripherals Connectivity Solutions Guide</i>
5966-5171	<i>HP JetDirect Software Installation Guide</i> (English)
C3989-60115	<i>HP Color LaserJet 8500, 8500N, 8500 DN Service and Support CD-ROM</i>
C3983-67902	<i>HP Color LaserJet 8500, 8500N, 8500 DN Self-Paced Training Kit (NTSC)</i>
C3983-67903	<i>HP Color LaserJet 8500, 8500N, 8500 DN Self-Paced Training Kit (PAL)</i>
C3983-90919	<i>HP Color LaserJet 8500, 8500 N, 8500 DN Quick Reference Guide</i> (English)
C3989-90901	<i>HP Color LaserJet 8500, 8500 N, 8500 DN Getting Started Guide</i> (English)
C3989-90937	<i>HP Color LaserJet 8500, 8500 N, 8500 DN User's Guide</i> (English)

## Miscellaneous parts

**Table 50. Miscellaneous parts**

<b>Part number</b>	<b>Description</b>
C3983-40001	Control panel overlay, English
C3983-40002	Control panel overlay, Traditional Chinese
C3983-40003	Control panel overlay, Korean
C3983-40004	Control panel overlay, Simplified Chinese
C3983-40005	Control panel overlay, Portuguese
C3983-40006	Control panel overlay, French
C3983-40007	Control panel overlay, German
C3983-40008	Control panel overlay, Spanish
C3983-40009	Control panel overlay, Dutch
C3983-40010	Control panel overlay, Norwegian
C3983-40011	Control panel overlay, Swedish
C3983-40012	Control panel overlay, Finnish
C3983-40013	Control panel overlay, Danish

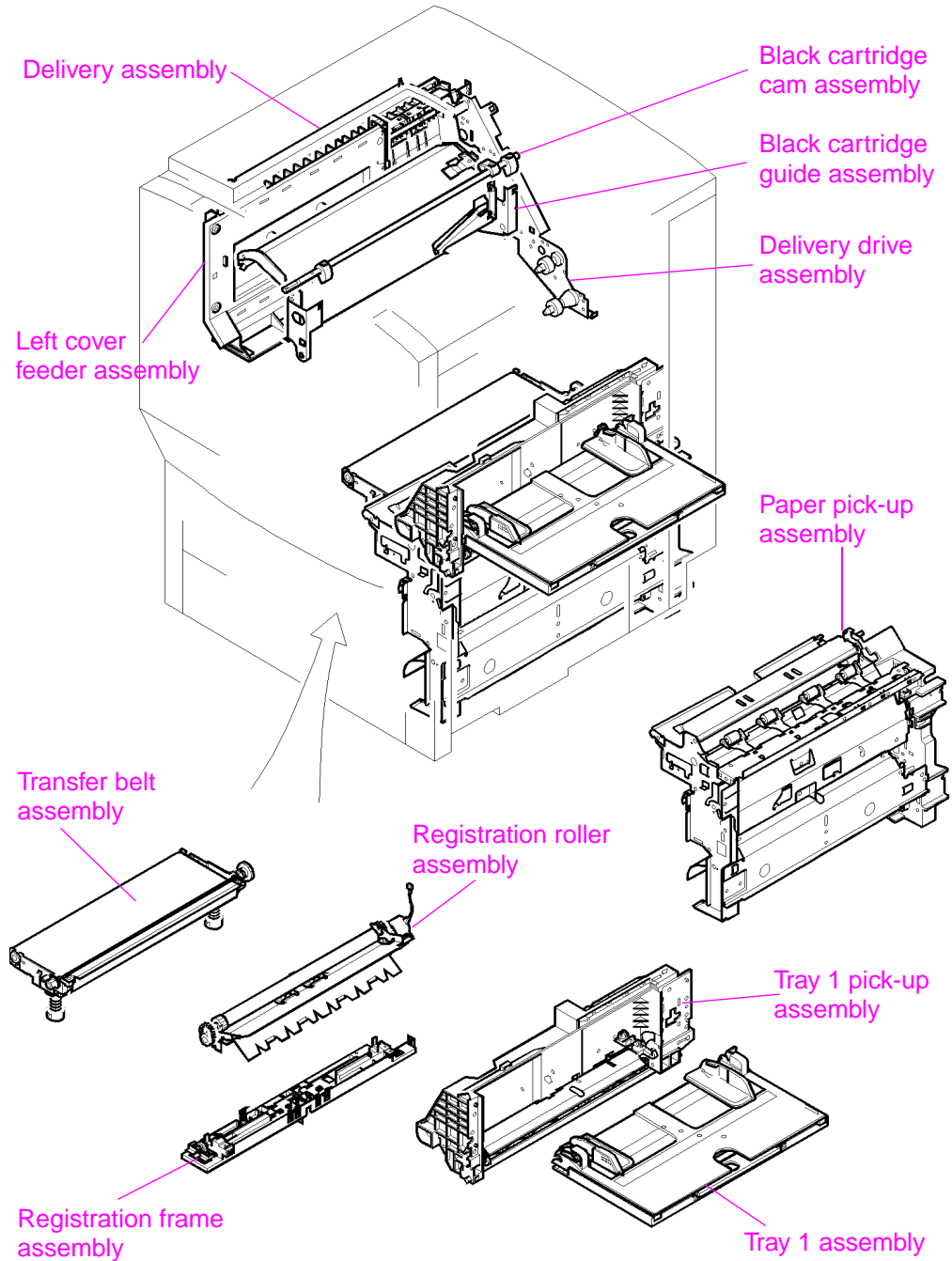
**Table 50. Miscellaneous parts (continued)**

<b>Part number</b>	<b>Description</b>
C3983-40014	Control panel overlay, Italian
C3983-40015	Control panel overlay, Russian
C3983-40016	Control panel overlay, Czech
C3983-67905	Formatter assembly
C4781-60500	Power box
C4785-60513	Multi-bin mailbox, repackaging kit
C4785-70001	Multi-bin mailbox, short C-link cable adapter
C4787-60503	Multi-bin mailbox, shipping lock kit
J3113-61003	PCA, 10/100Base-T
RY7-5044-000CN	Screw kit (2,000-sheet input unit)
XA9-0836-000CN	Screw, TP, M3 x 6, quantity 10
XA9-0926-000CN	Screw, TP, M4 x 8, quantity 10
XA9-0940-000CN	Screw, w/washer, M4 x 12, quantity 4
XA9-0951-000CN	Screw, w/washer, M3 x 8, quantity 10

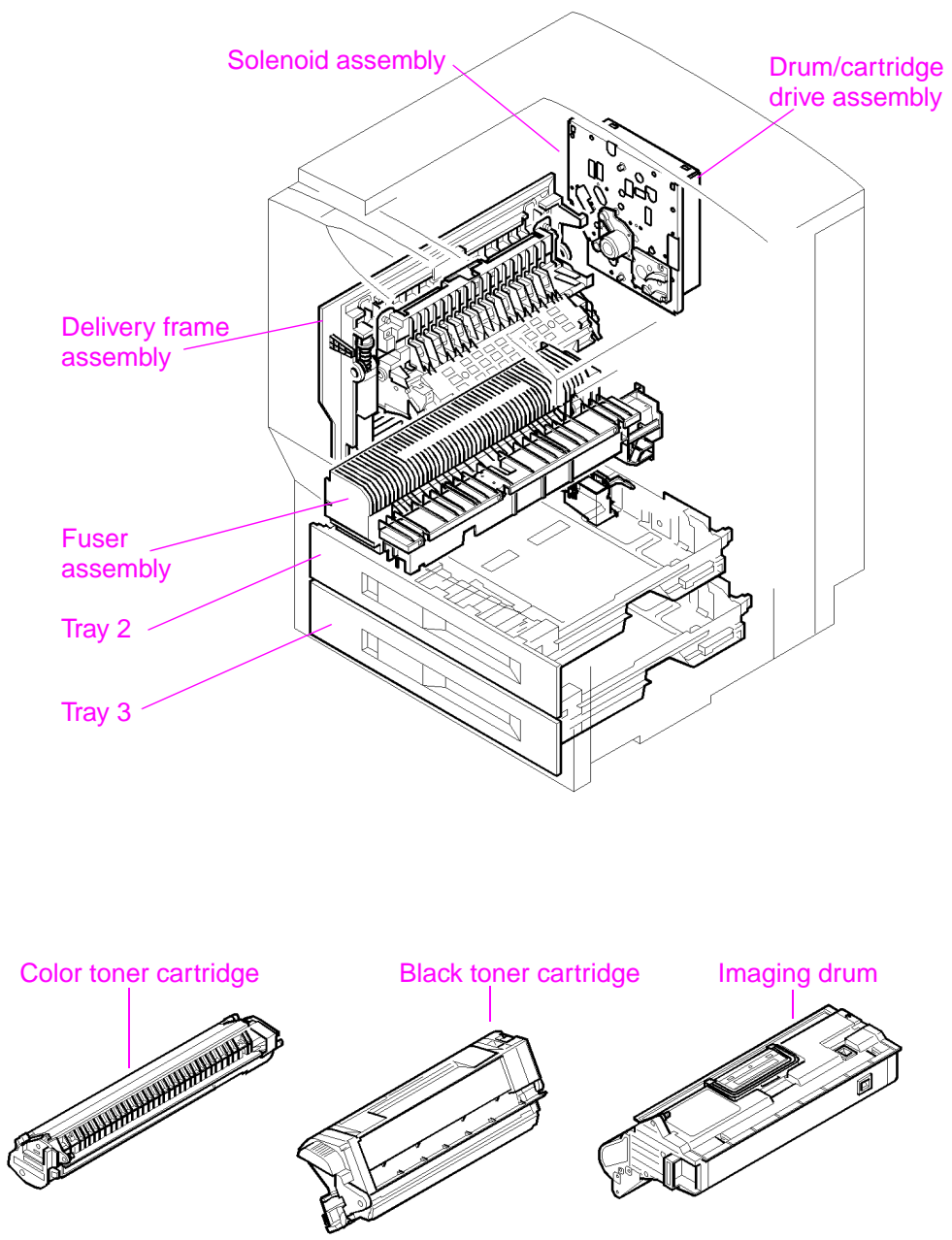
## Illustrations and parts lists

The following illustrations and their assorted parts tables list the field replaceable units (FRUs) for this printer. At the end of this chapter, there are two cross-reference tables of all of the parts listed in this chapter: table 81 lists the parts in numerical order by part number, and table 82 lists the parts in alphabetical order. Both tables are cross-referenced to the appropriate figure and reference number in this chapter.

## Major assembly locations

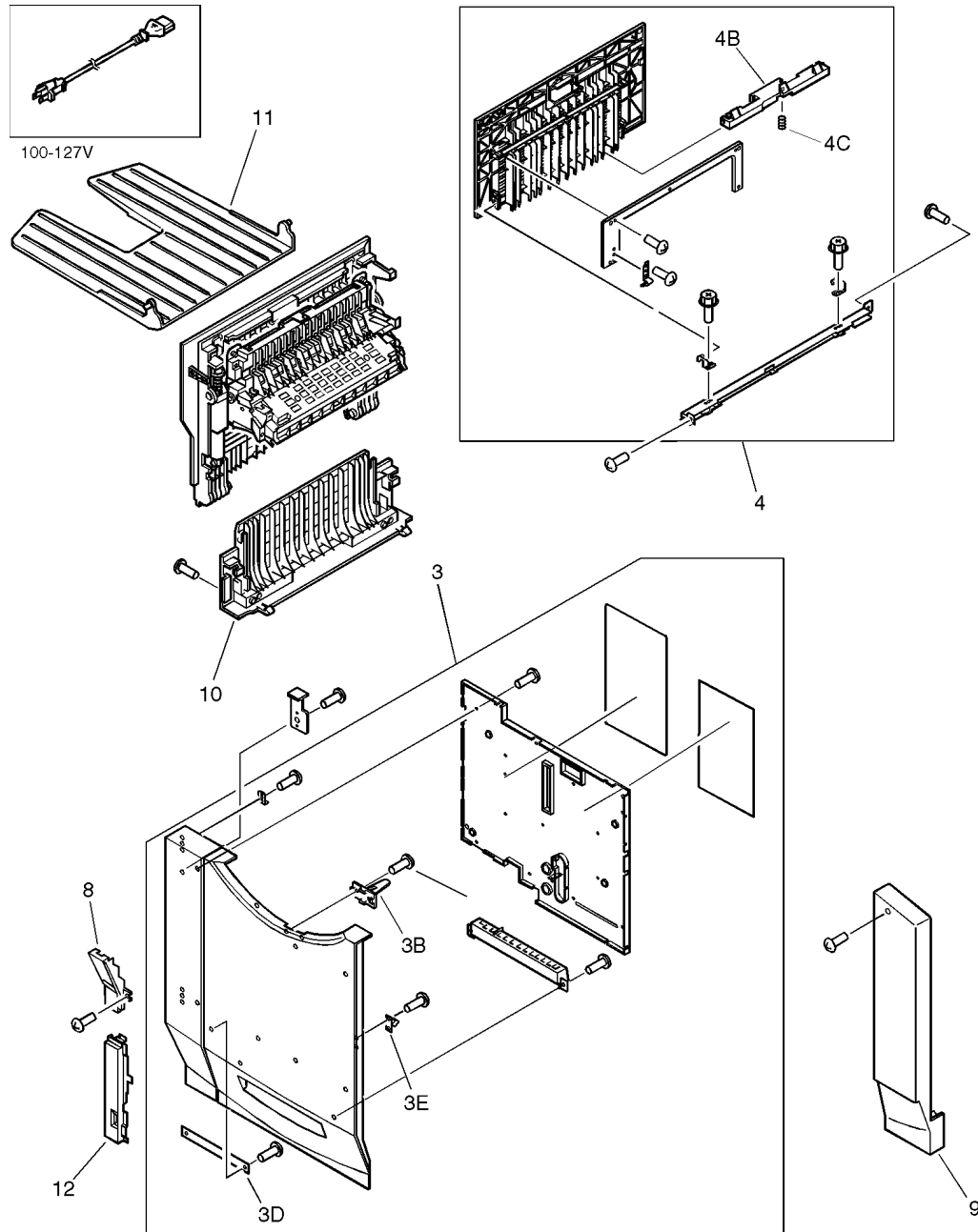


**Figure 212.** Major assembly locations (1 of 2)



**Figure 213. Major assembly locations (2 of 2)**

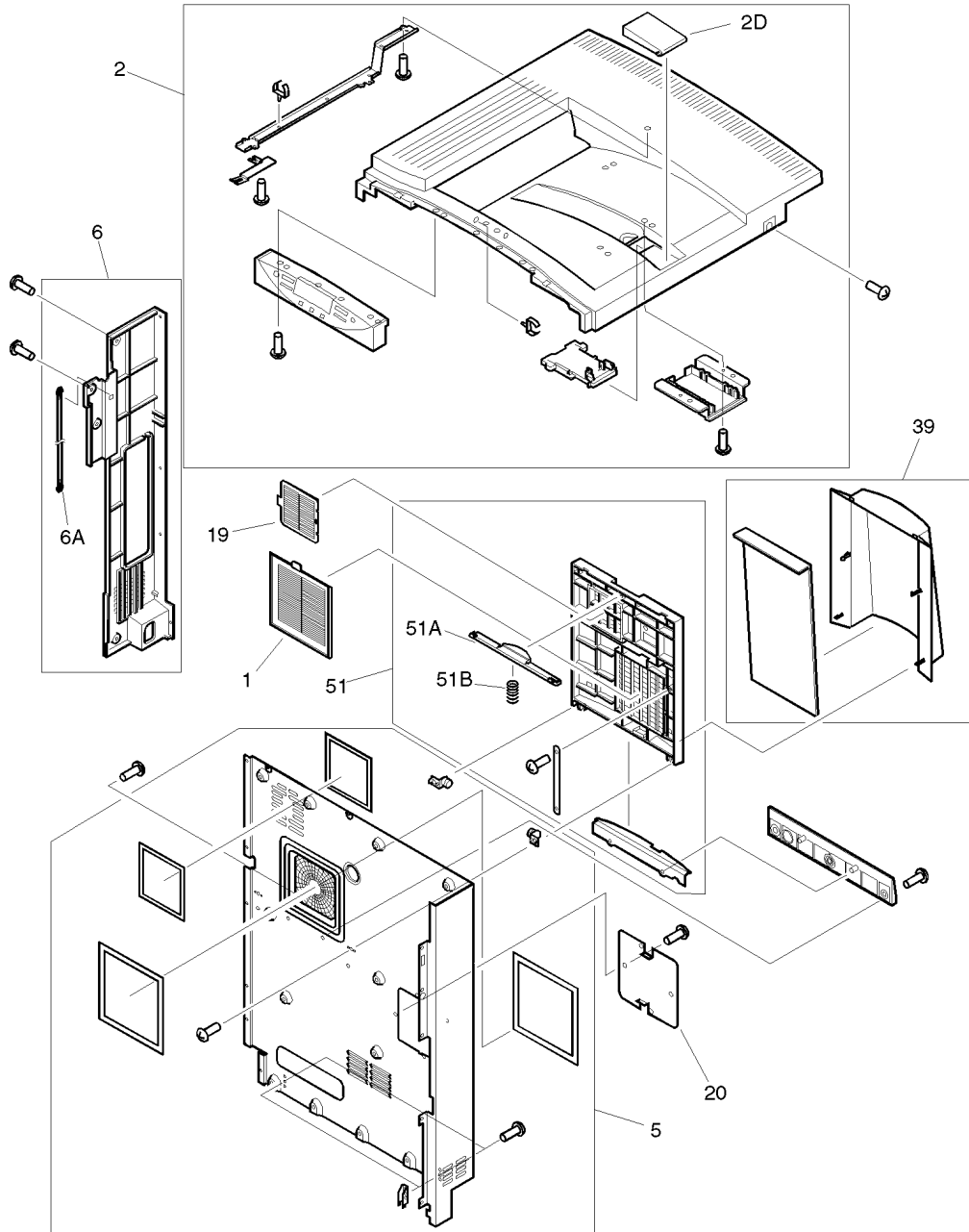
## Printer covers and doors



**Figure 214.** Printer covers and doors (1 of 3)

**Table 51. Printer doors and covers (1 of 3)**

<b>Ref.</b>	<b>Description</b>	<b>Part number</b>	<b>Qty.</b>
3	Cover assembly, front	RG0-0112-000CN	1
3B	Lever, shutter	RA0-0008-000CN	1
3D	Strap, front door support	RB1-4497-000CN	1
3E	Latch, roller action	RB1-5153-000CN	1
4	Cover assembly, left upper	RG0-0113-000CN	1
4B	Lever, left upper door	RB1-6485-000CN	1
4C	Spring, left upper door lever	RB1-6486-000CN	1
8	Cover, hinge	RA0-0068-000CN	1
9	Cover, front right	RA0-0069-000CN	1
10	Cover, left lower	RB1-6480-000CN	1
11	Tray, face-up	RB1-6491-000CN	1
12	Cover, power switch	RB1-6492-000CN	1

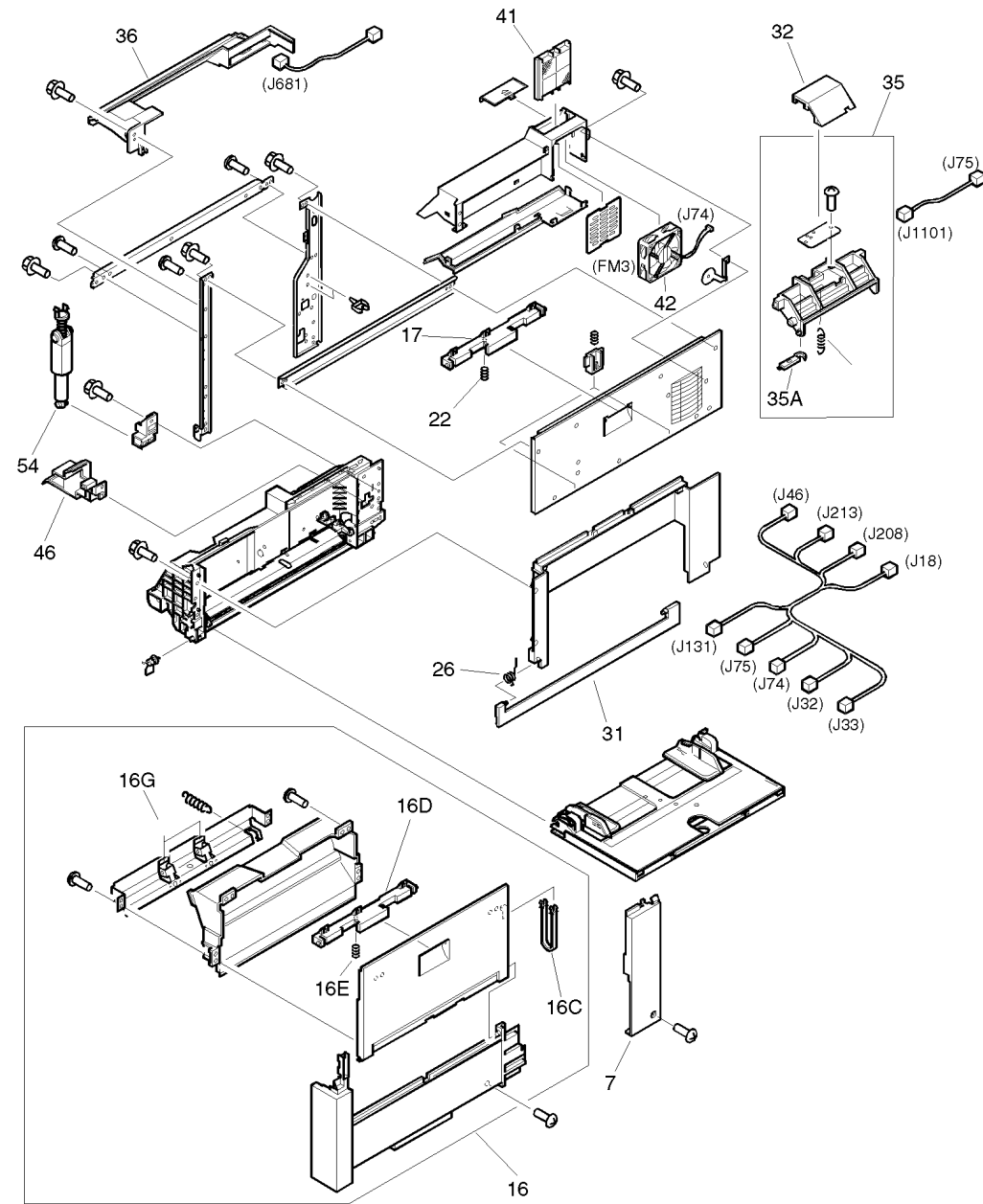


**Figure 215. Printer covers and doors (2 of 3)**



**Table 52. Printer doors and covers (2 of 3)**

<b>Ref.</b>	<b>Description</b>	<b>Part number</b>	<b>Qty.</b>
1	Filter, large air	RB1-9807-000CN	1
2	Cover assembly, top	RG0-0111-000CN	1
2D	Stop, flip-up media	RA0-0073-000CN	1
5	Cover assembly, rear	RG0-0115-000CN	1
6	Cover, left rear	RA0-0065-000CN	1
6A	Stopper, open/close	RB1-6484-000CN	1
19	Filter, small air	RB1-9808-000CN	1
20	Cover, auxiliary	RA0-0078-000CN	1
39	Cover, fan	RF0-0012-000CN	1
51	Cover, rear fan housing	RG0-0017-000CN	1
51A	Support, cover	RA0-0079-000CN	1
51B	Spring, compression	RS5-2719-000CN	1

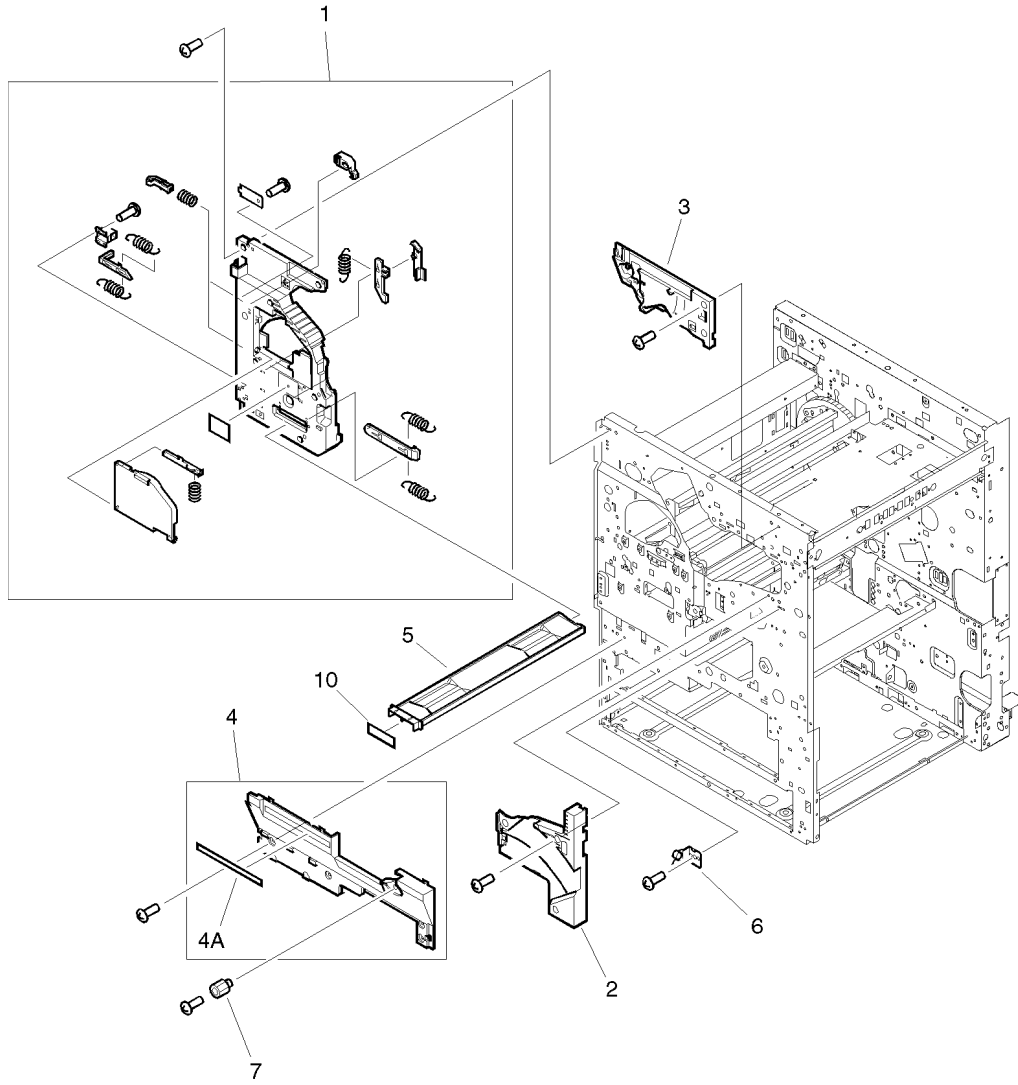


**Figure 216. Printer covers and doors (3 of 3)**

**Table 53. Printer covers and doors parts**

<b>Ref.</b>	<b>Description</b>	<b>Part number</b>	<b>Qty.</b>
7	Cover, right rear	RA0-0067-000CN	1
16	Cover assembly, right lower	RG5-3096-000CN	1
16C	Stopper, open/close	RB1-6484-000CN	1
16D	Lever, right lower cover	RB1-6485-000CN	1
16E	Spring, compression	RB1-6486-000CN	1
16G	Roller, paper	RB1-6488-000CN	2
17	Lever, right upper door	RB1-6485-000CN	1
22	Spring, right lower door lever	RB1-6486-000CN	1
26	Spring, torsion	RB1-9798-000CN	1
31	Cover, right subassembly	RF5-1995-000CN	1
32	Cover, density sensor	RB1-9537-000CN	1
35	Density sensor assembly	RG5-3057-000CN	1
35A	Brush, cleaning	RB1-9617-000CN	1
36	Preconditioning exposure LED assembly	RG5-3980-000CN	1
41	Filter, charcoal	RB1-9836-000CN	1
42	Fan 3 (FM3)	RH7-1393-000CN	1
46	Cover, tray 1 side gear	RB1-9547-000CN	1
54	Hinge, stopper (tray 1 delivery assembly)	RG5-3962-000CN	1

## Internal cover assembly

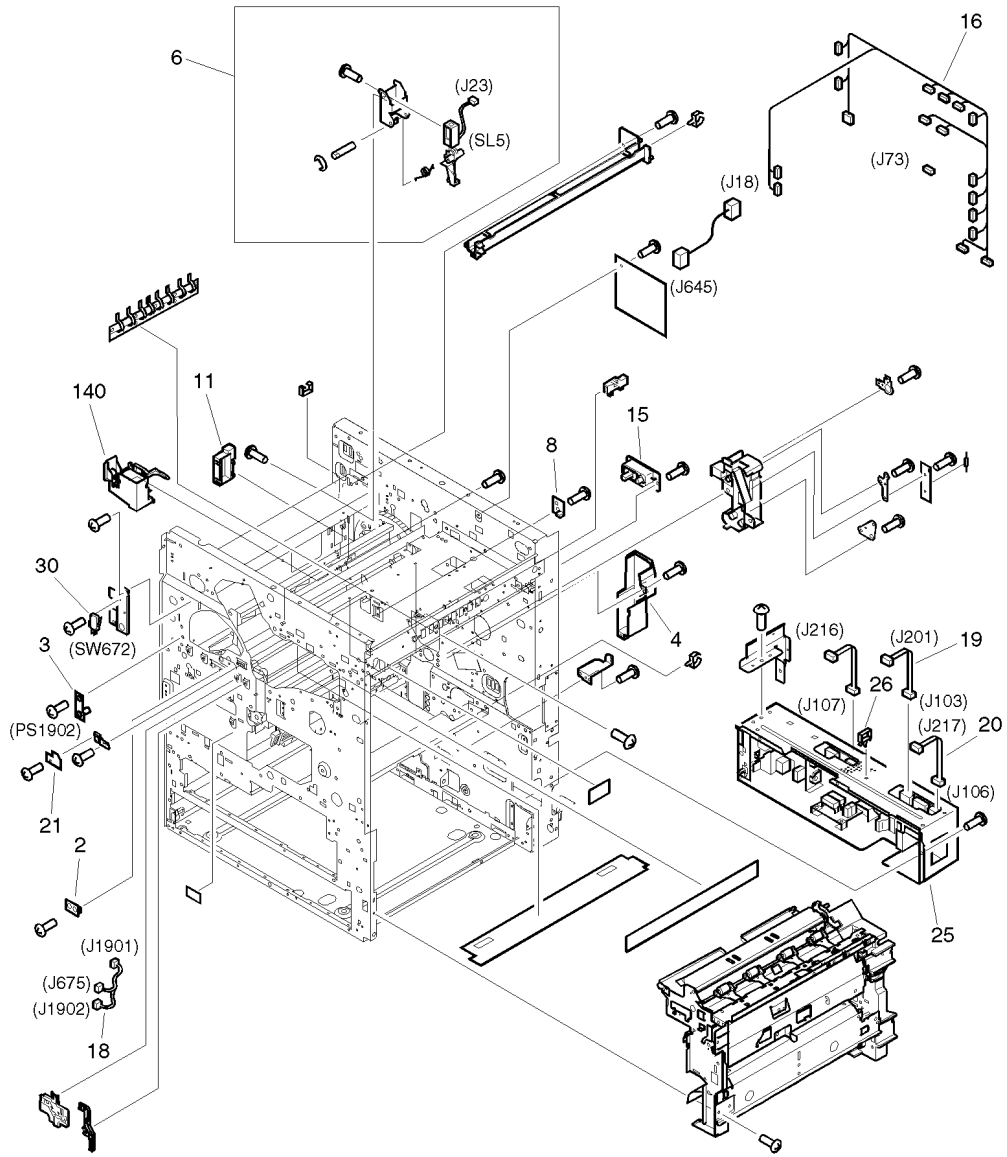


**Figure 217.** Internal cover assembly

**Table 54. Internal cover assembly parts**

<b>Ref.</b>	<b>Description</b>	<b>Part number</b>	<b>Qty.</b>
1	Cover assembly, inner left	RG0-0104-000CN	1
2	Cover, inner 2	RA0-0026-000CN	1
3	Cover, inner 3	RA0-0027-000CN	1
4	Cover, inner 4	RF0-0013-000CN	1
4A	Label, "CAUTION"	RS5-8380-000CN	1
5	Waste toner tray	RB1-9804-000CN	1
6	Latch, roller action	RF0-0003-000CN	1
7	Media jam knob	RB1-9928-000CN	1
10	Cover, waste toner tray	RA0-0083-000CN	1

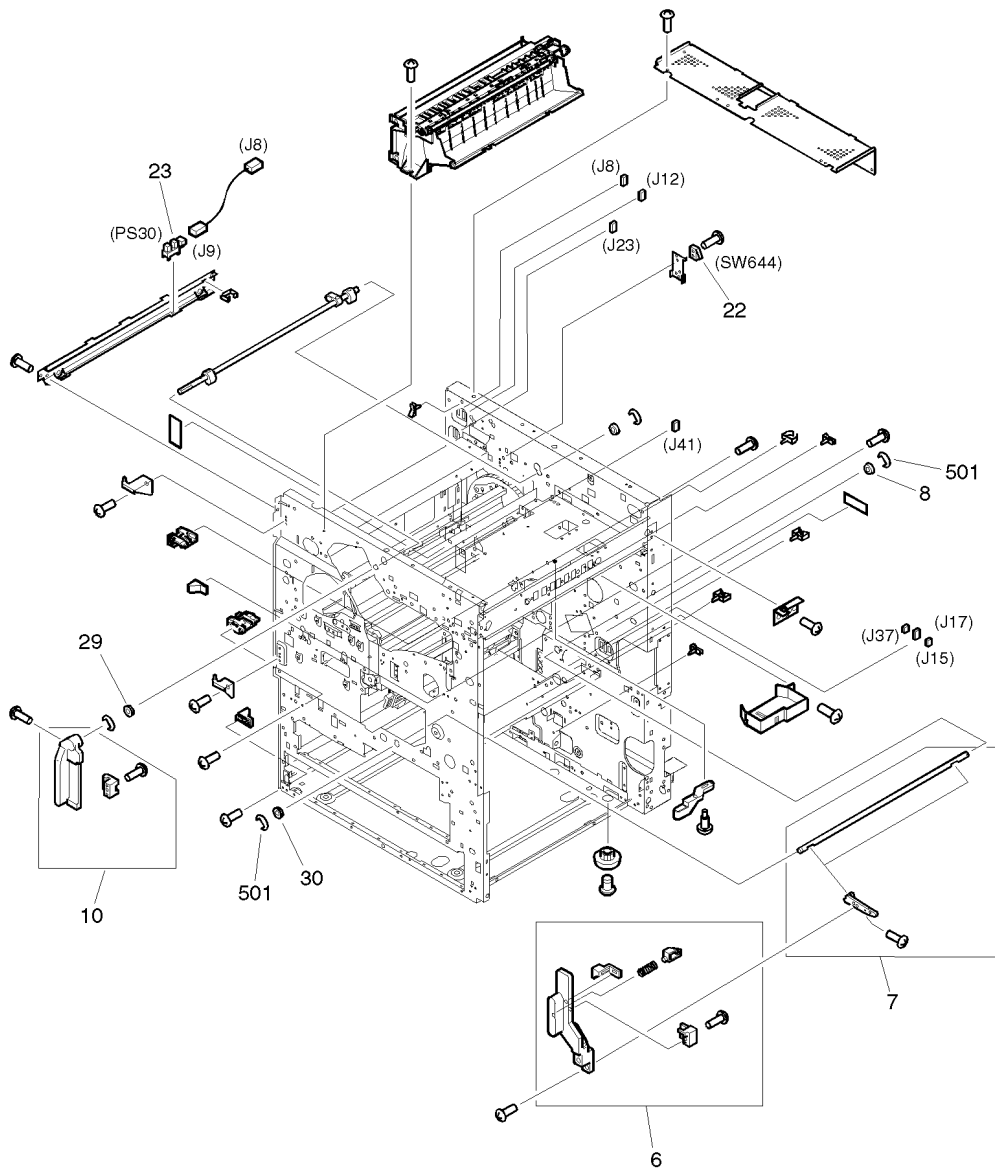
# Internal components



**Figure 218.** Internal components (1 of 6)

**Table 55. Internal components parts (1 of 6)**

<b>Ref.</b>	<b>Description</b>	<b>Part number</b>	<b>Qty.</b>
2	PCA, photosensor	RG5-3080-000CN	1
3	Plate, duct mount	RF5-2036-000CN	1
4	Duct, rear lower air	RB1-9401-000CN	1
6	Carousel stop assembly	RG5-3053-000CN	1
8	PCA, fusing delivery sensor	RG5-3992-000CN	1
11	Cover, carousel stop	RB1-9789-000CN	1
15	Connector holder assembly	RG5-3031-000CN	1
16	Cable, main	RG5-3097-000CN	1
18	Cable, sensor	RG5-3144-000CN	1
19	Cable, DC power	RG5-3921-000CN	1
20	Cable, power signal	RG5-3922-000CN	1
21	PCA, cartridge release lever	RG5-3961-000CN	1
25	Power supply assembly (110V) Power supply assembly (220V)	RH3-2185-000CN RH3-2187-000CN	1
30	Switch, toner cartridge cover (SW672)	WC4-5150-000CN	1
140	Face-up solenoid assembly	RG5-3022-000CN	1



**Figure 219. Internal components (2 of 6)**



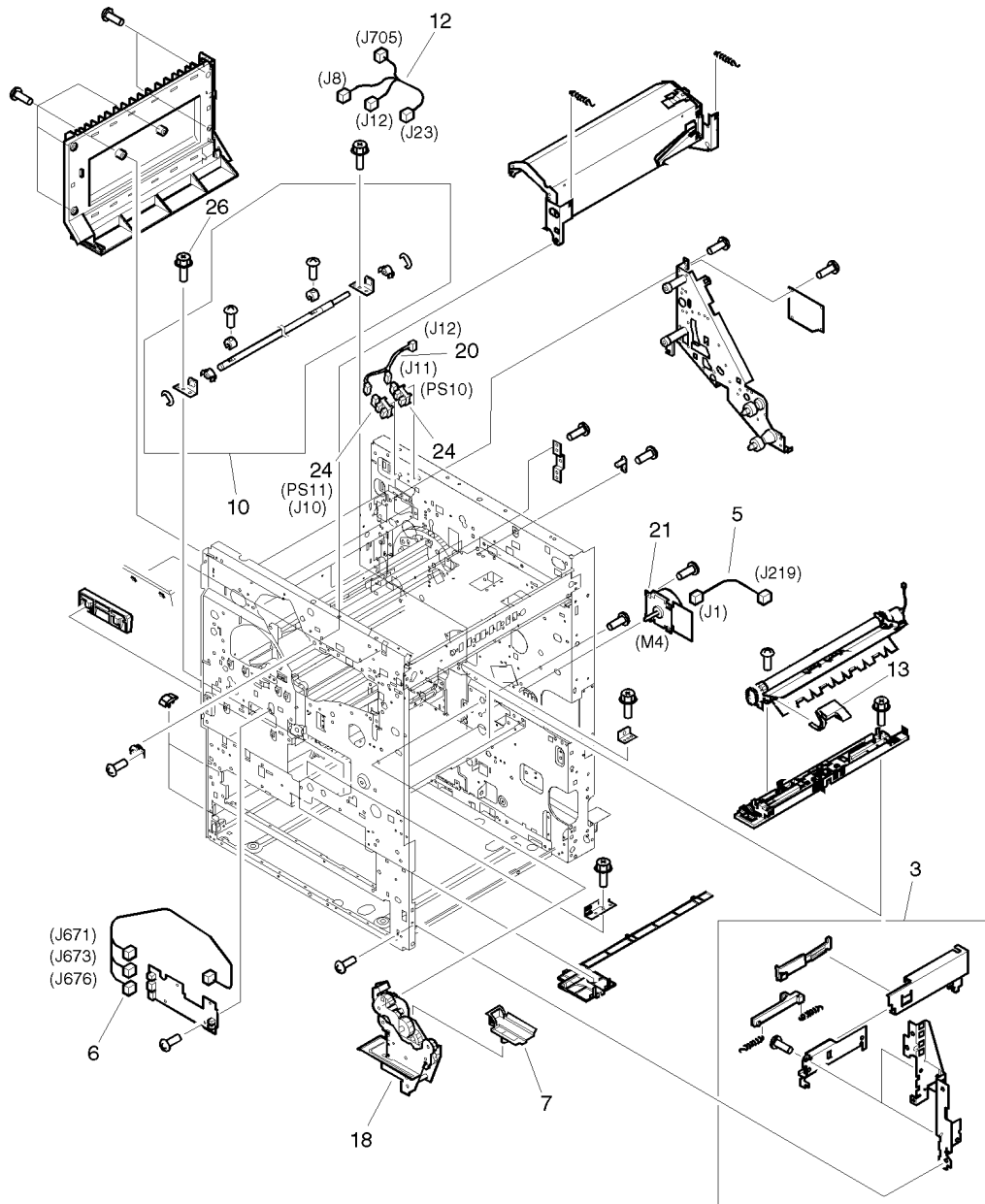
**Table 56. Internal components parts (2 of 6)**

<b>Ref.</b>	<b>Description</b>	<b>Part number</b>	<b>Qty.</b>
6	Lever assembly, transfer drum	RG5-3046-000CN	1
7	Lever assembly, pressure	RG5-3045-000CN	1
8	Bushing	RS5-1119-000CN	1
10	Lever assembly, black cartridge	RG5-3087-000CN	1
22	Switch, black toner cartridge (SW644)	WC4-5136-000CN	1
23	Photo-interrupter, IC, TLP1240	WG8-5210-000CN	1
29	Bushing	RS5-1317-000CN	1
30	Bushing	RS5-1317-000CN	1
501	Ring, E	XD2-1100-642CN	2



**Table 57. Internal components parts (3 of 6)**

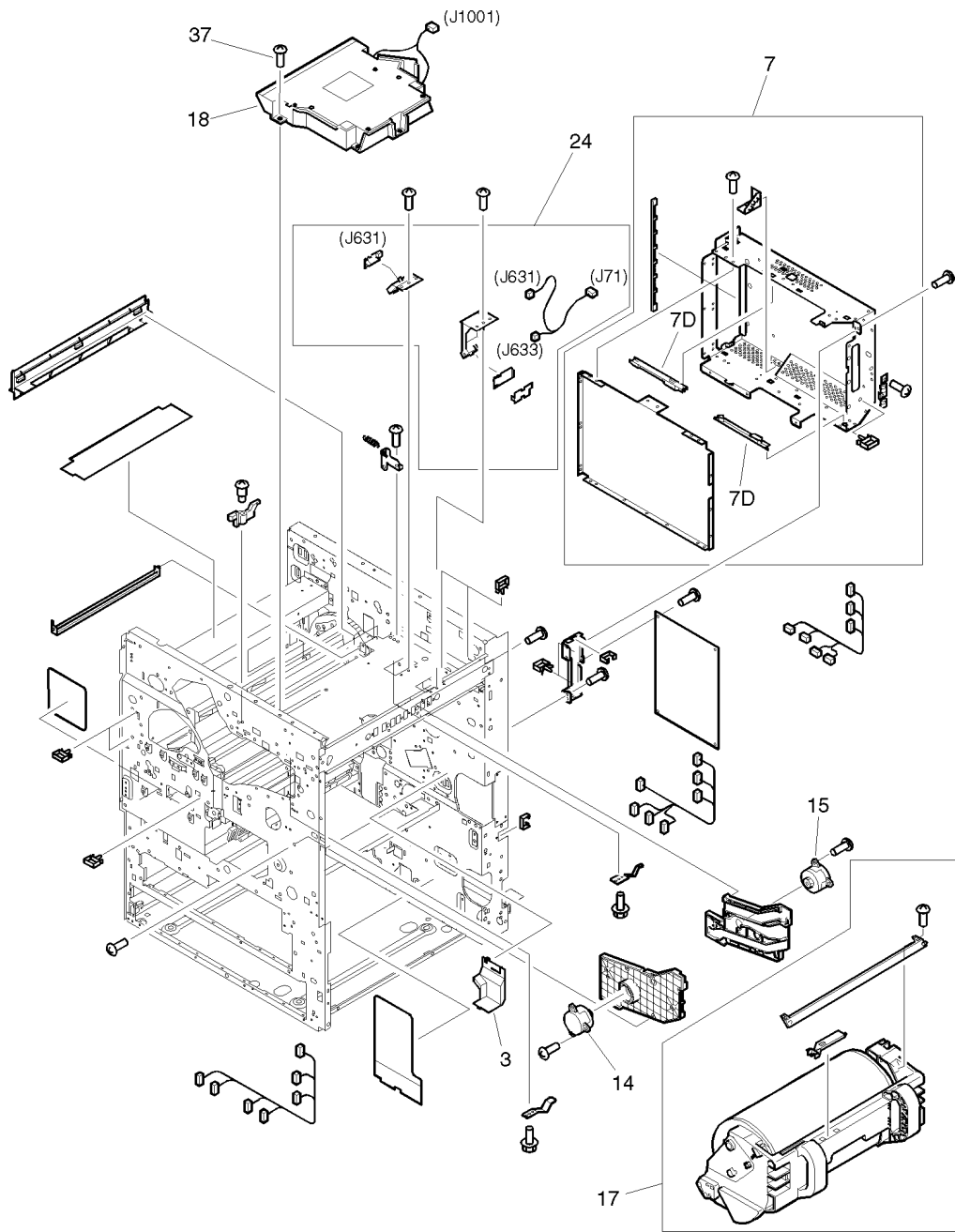
<b>Ref.</b>	<b>Description</b>	<b>Part number</b>	<b>Qty.</b>
1	Cover, right rear lower corner	RA0-0074-000CN	1
2	Transfer drum contact assembly	RG5-3044-000CN	1
4	Spring, compression	RB1-9675-000CN	3
5	Rod, power switch	RB1-6463-000CN	1
6	Spring, leaf	RB1-6909-000CN	1
7	Gear, 11T	RB1-9424-000CN	1
8	Sensor assembly, color toner	RG5-3034-000CN	1
9	Cover, cable	RB1-9805-000CN	1
15	Mount, clutch	RB1-9828-000CN	1
20	PCA, high-voltage converter 1	RG5-3026-000CN	1
21	PCA, high-voltage converter 2	RG5-3943-000CN	1
24	High-voltage converter 1	RH3-0211-000CN	1
25	High-voltage converter 2	RH3-0228-000CN	1
26	Motor, carousel (M1)	RH7-1325-000CN	1
27	Clutch, transfer belt press (CL4)	RH7-5168-000CN	1
28	Spring, tension	RS5-2465-000CN	1
30	Separation discharge high-voltage converter PCA	RG5-3966-000CN	1
39	Separation discharge high-voltage converter	RH3-0234-000CN	1
501	Ring, E	XD2-1100-502CN	2



**Figure 221.** Internal components (4 of 6)

**Table 58. Internal components parts (4 of 6)**

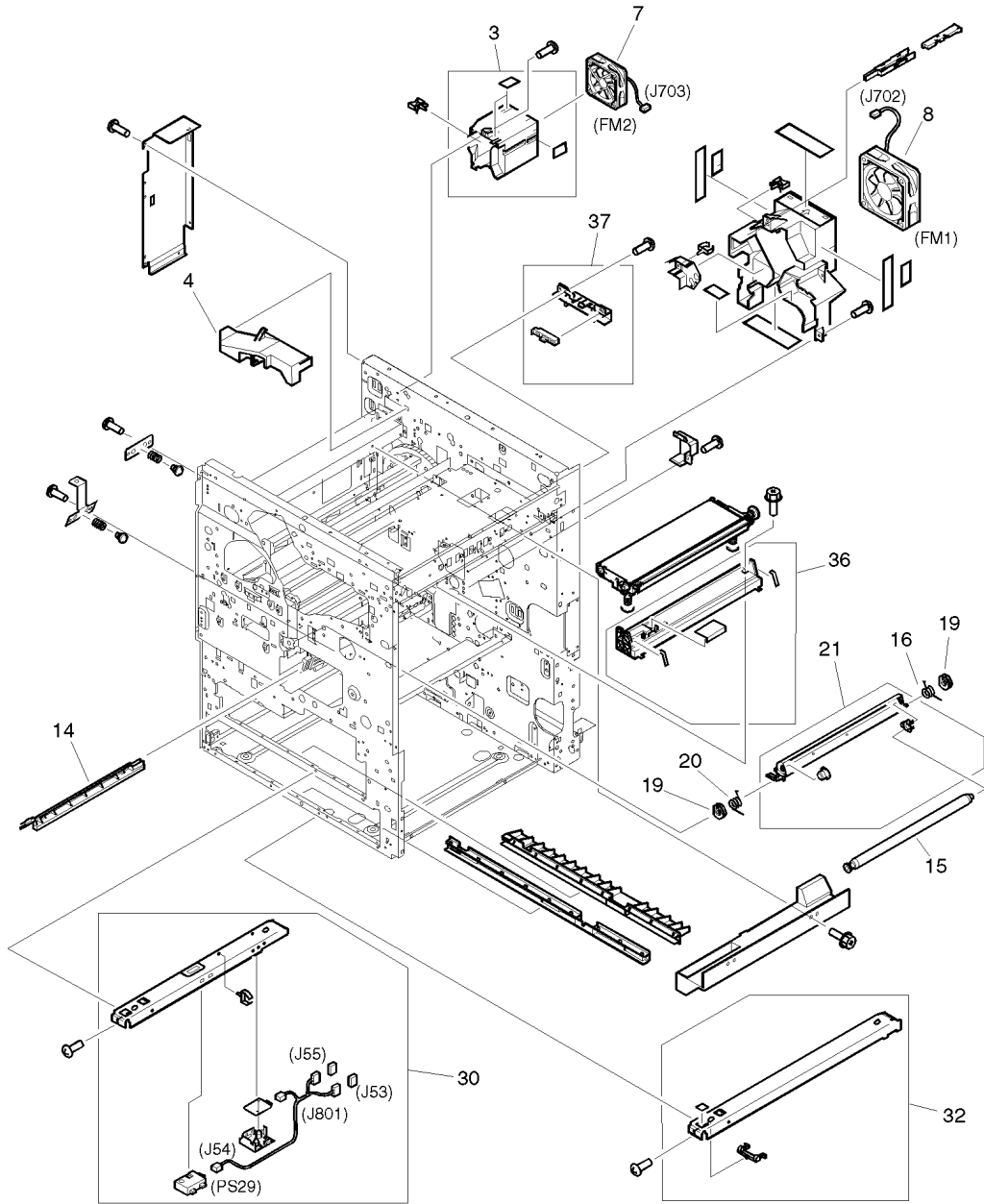
<b>Ref.</b>	<b>Description</b>	<b>Part number</b>	<b>Qty.</b>
3	Tray rail assembly	RG5-1851-000CN	1
5	Cable, main motor	RG5-3942-000CN	1
6	Cable, carousel	RG5-3923-000CN	1
7	Cover, gear	RB1-9403-000CN	1
10	Transfer swing assembly	RG5-3010-000CN	1
12	Cable, delivery connector	RG5-3147-000CN	1
13	Lever, registration roller	RB1-9580-000CN	1
18	Main drive assembly	RG5-3066-000CN	1
20	Cable, delivery	RG5-3104-000CN	1
21	Motor, main (M4)	RH7-1323-000CN	1
24	Photo-interrupter, IC, TLP1241	WG8-5362-000CN	1
26	Screw, RS, M3 x 6	XA9-0849-000CN	10



**Figure 222.** Internal components (5 of 6)

**Table 59. Internal components parts (5 of 6)**

<b>Ref.</b>	<b>Description</b>	<b>Part number</b>	<b>Qty.</b>
3	Cover, cable	RB1-9948-000CN	1
7	Shield case assembly	RG5-3023-000CN	1
7D	Rail, PCA	RB2-0005-000CN	1
14	Gear, 14T	RB1-9955-000CN	1
15	Gear, 14T	RB1-9956-000CN	1
17	Transfer drum	RG5-3039-000CN	1
18	Laser/scanner unit	RG5-3936-000CN	1
24	Sensor assembly, toner waste	RG5-3934-000CN	1
37	Screw, w/washer, M4 x 12	XA9-0940-000CN	4



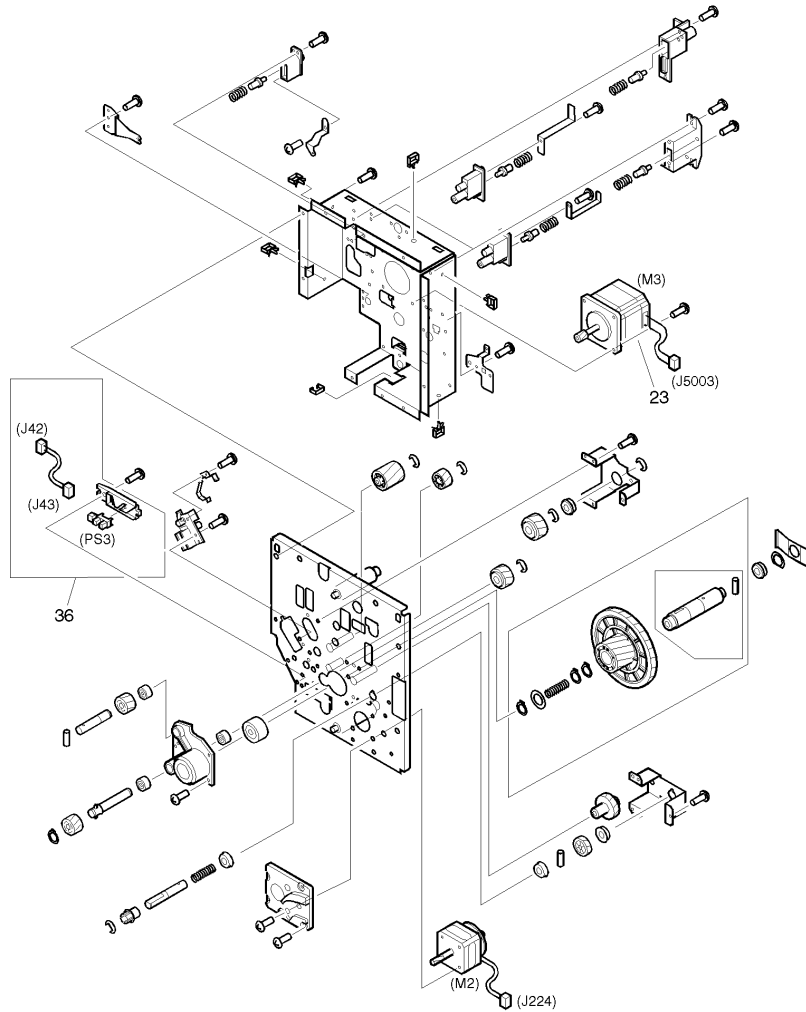
**Figure 223. Internal components (6 of 6)**



**Table 60. Internal components parts (6 of 6)**

<b>Ref.</b>	<b>Description</b>	<b>Part number</b>	<b>Qty.</b>
3	Holder, fan	RF5-2025-000CN	1
4	Duct	RB1-9682-000CN	1
7	Fan 2 (FM2)	RH7-1373-000CN	1
8	Fan 1 (FM1)	RH7-1330-000CN	1
14	Static charge eliminator assembly	RG5-3973-000CN	1
15	Cleaning roller assembly	RG5-3975-000CN	1
16	Spring, torsion	RS5-2698-000CN	1
19	Bushing	RS5-1319-000CN	2
20	Spring, torsion	RS5-2697-000CN	1
21	Transfer drum cleaner holder assembly	RG5-3111-000CN	1
30	Cassette crossmember assembly	RG5-3089-000CN	1
32	Rail, tray 3	RF5-1396-000CN	1
36	Transfer mount assembly	RG5-3008-000CN	1
37	Sensor slider assembly	RG5-3131-000CN	1

## Drum/cartridge drive assembly

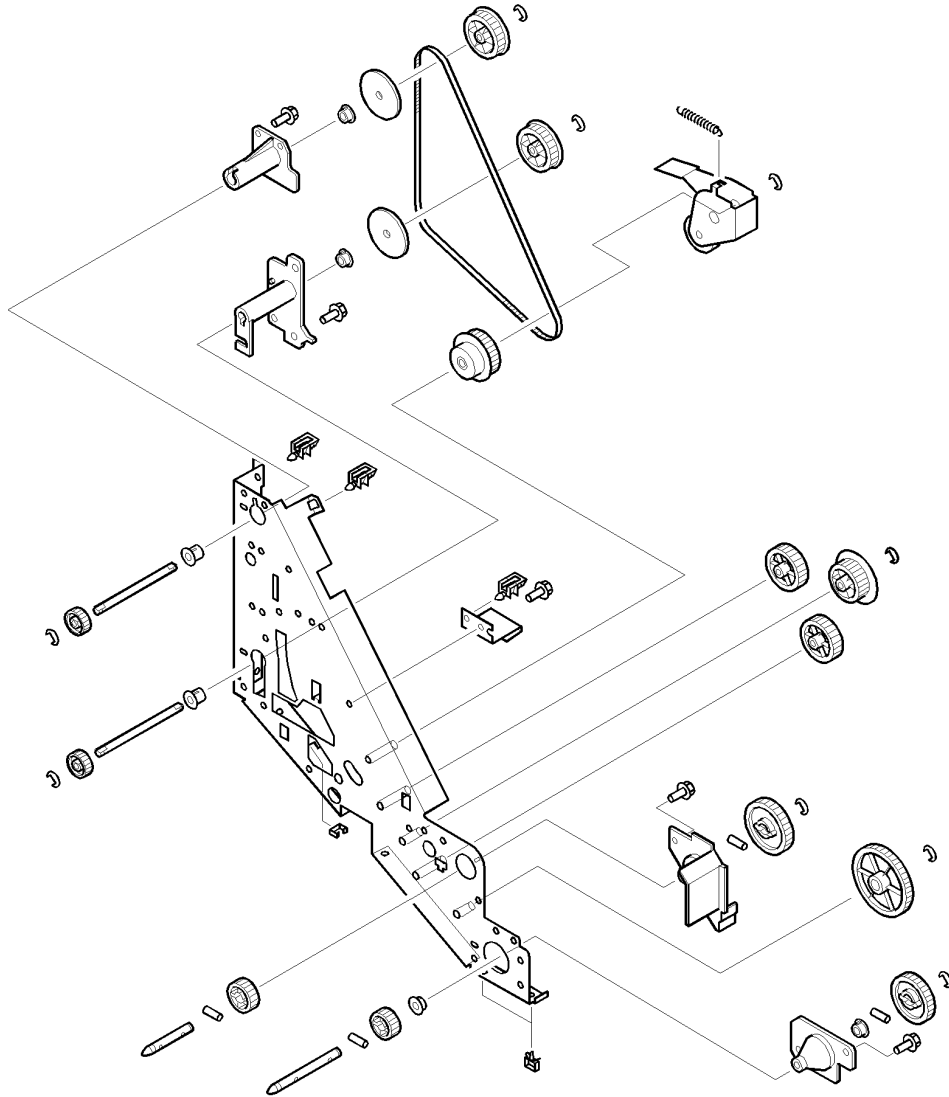


**Figure 224.** Drum/cartridge drive assembly

**Table 61.** Drum/cartridge drive assembly parts

Ref.	Description	Part number	Qty.
—	Drum/cartridge drive assembly	RG5-3065-000CN	1
23	Motor, cartridge (M3)	RH7-1328-000CN	1
36	Developing rotary	RG5-3033-000CN	1

## Delivery drive assembly

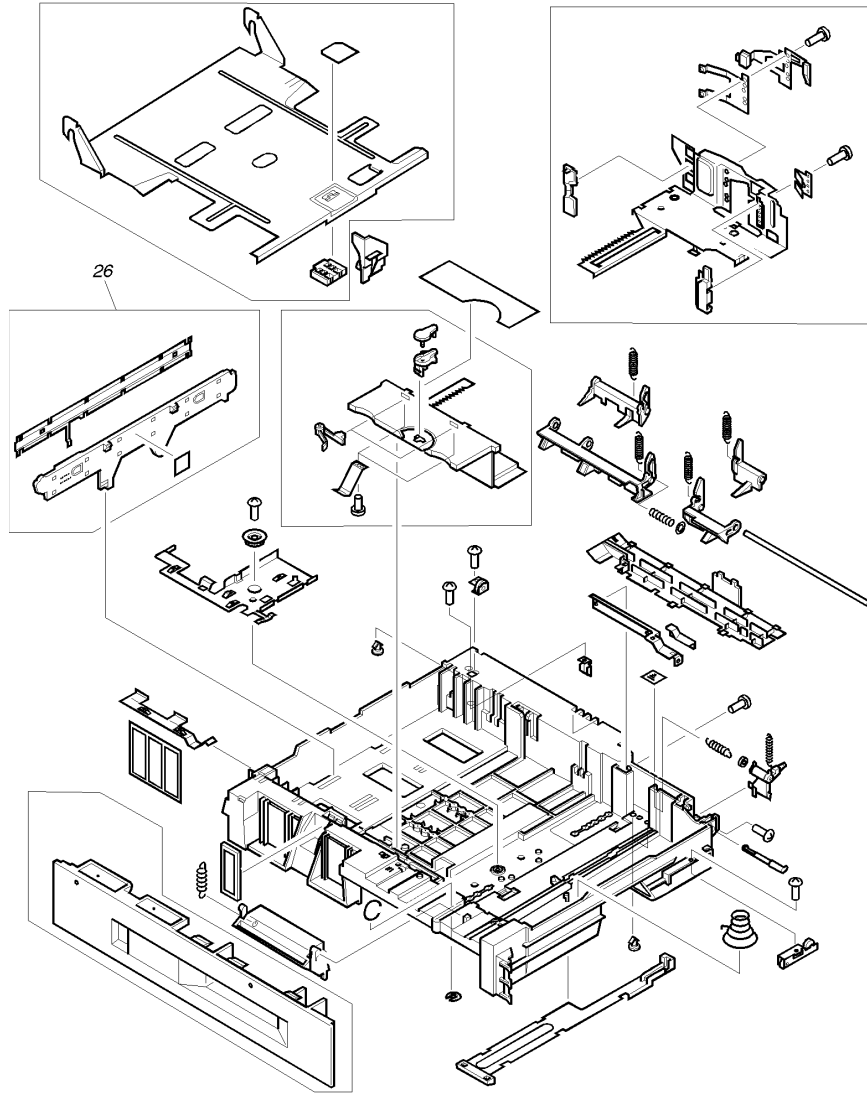


**Figure 225.** Delivery drive assembly

**Table 62.** Delivery drive assembly parts

Ref.	Description	Part number	Qty.
—	Delivery drive assembly	RG5-3067-000CN	1

## Tray 3 assembly

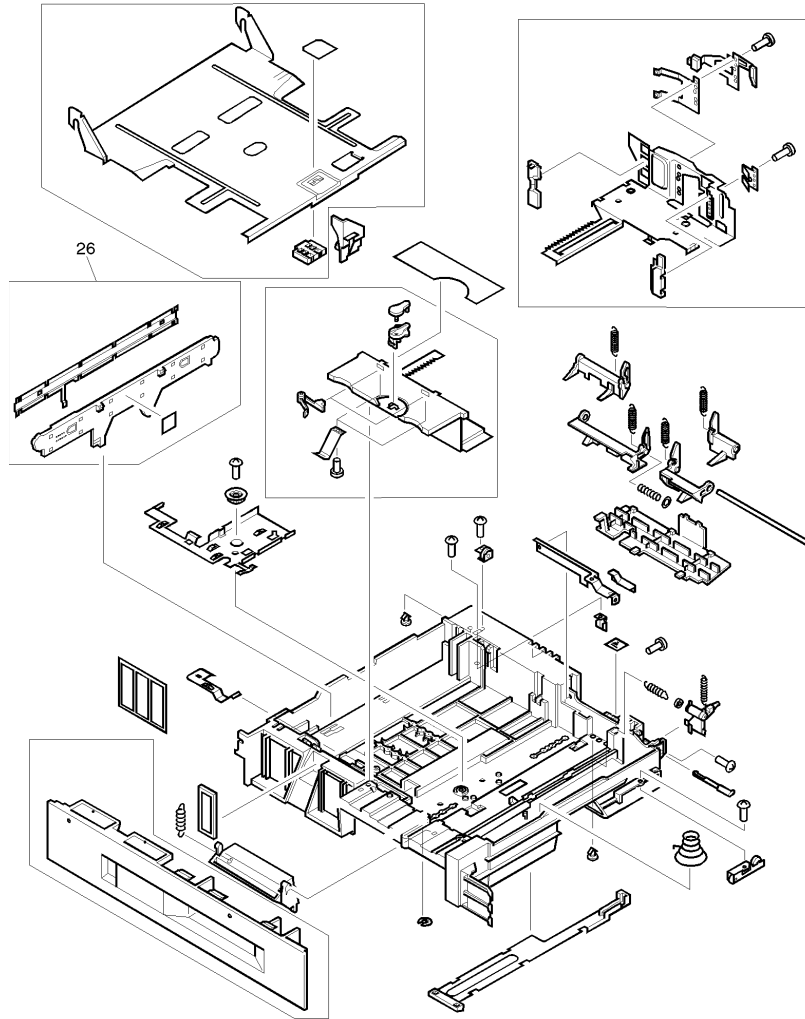


**Figure 226.** Tray 3 assembly

**Table 63.** Tray 3 assembly parts

Ref.	Description	Part number	Qty.
—	Tray 3	—	1
26	Plate, end	RF5-1484-000CN	1

## Tray 2 assembly

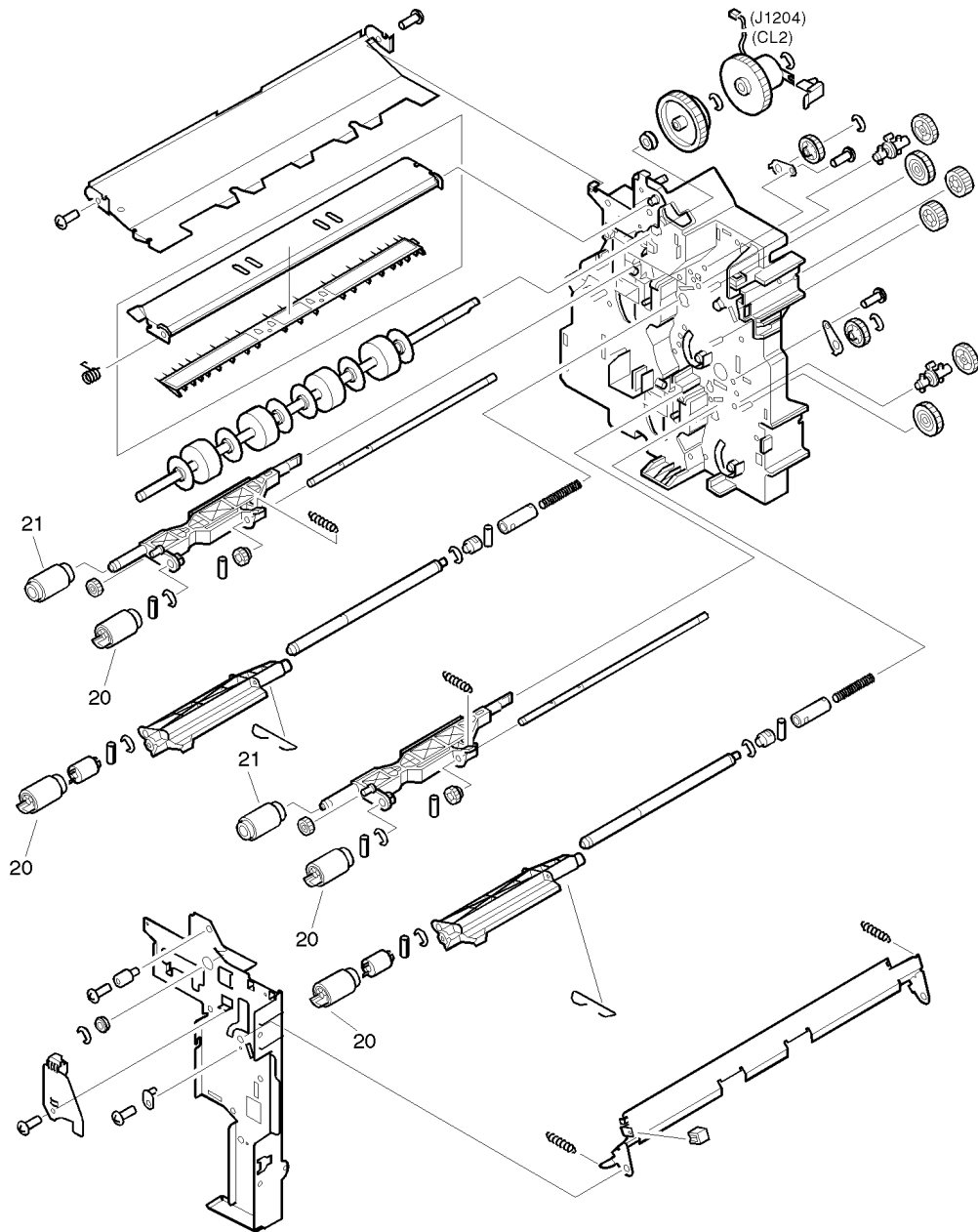


**Figure 227.** Tray 2 assembly

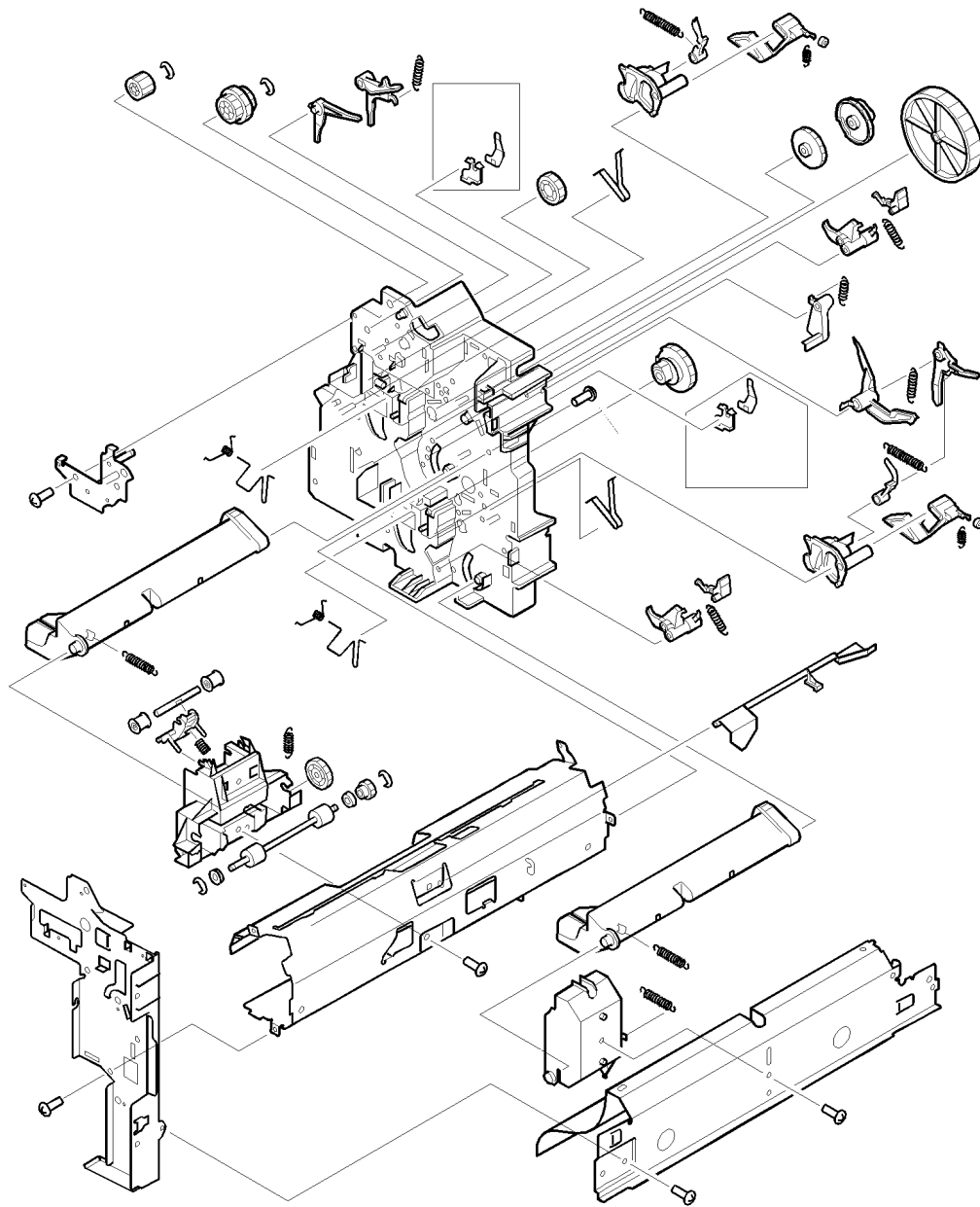
**Table 64.** Tray 2 assembly

Ref.	Description	Part number	Qty.
—	Tray 2	—	1
26	Plate, end	RF5-1484-000CN	1

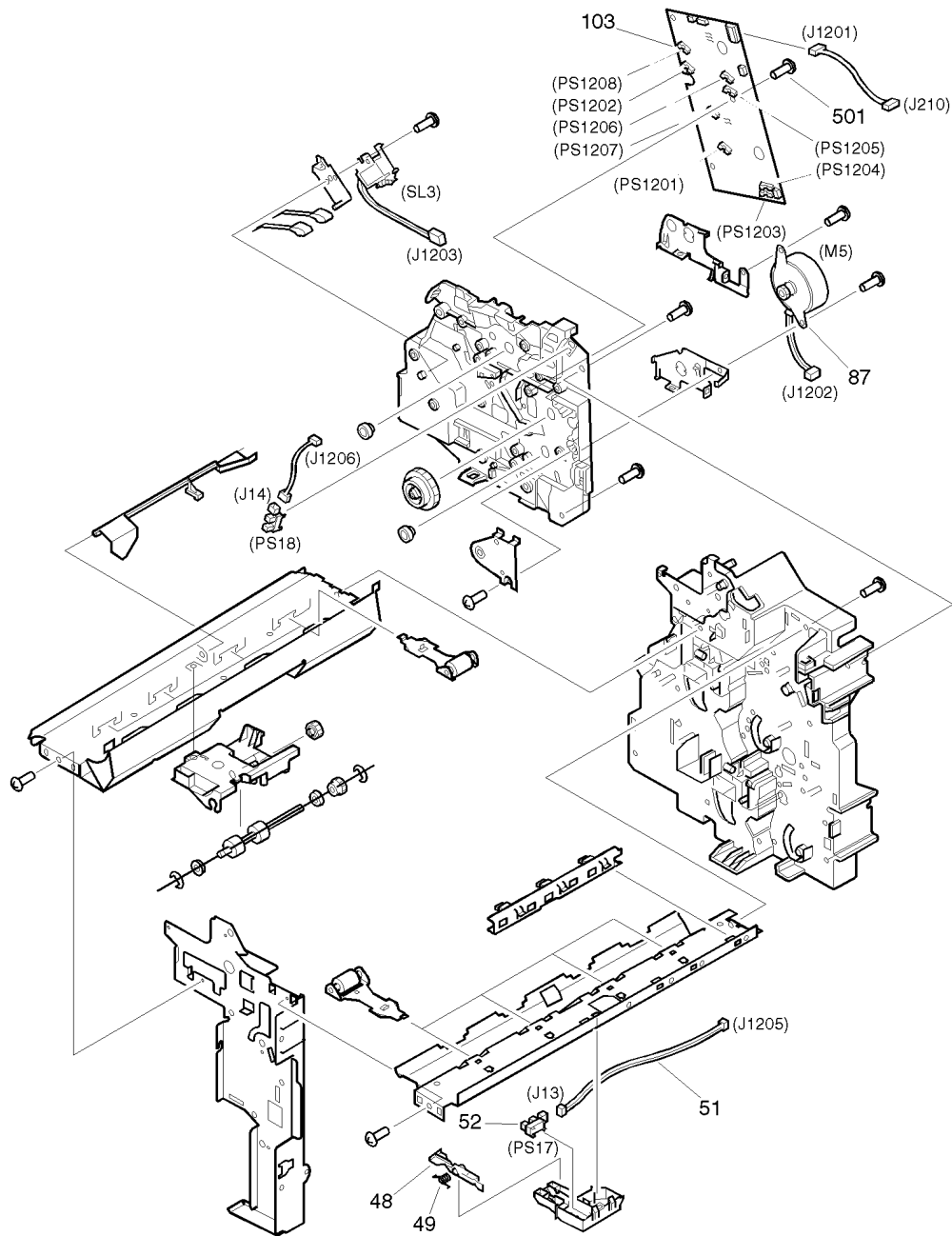
## Paper pick-up assembly



**Figure 228.** Paper pick-up assembly (1 of 3)



**Figure 229.** Paper pick-up assembly (2 of 3)



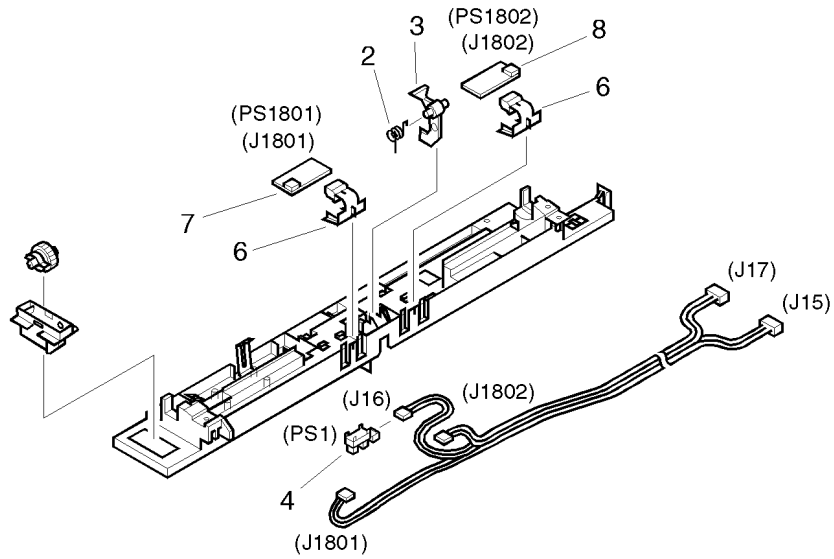
**Figure 230. Paper pick-up assembly (3 of 3)**



**Table 65. Paper pick-up assembly parts**

<b>Ref.</b>	<b>Description</b>	<b>Part number</b>	<b>Qty.</b>
—	Paper pick-up assembly	RG5-3132-000CN	1
20	Roller, feed	RF5-1834-000CN	1
21	Roller, pick-up	RF5-1835-000CN	2
48	Flag, paper sensing	RB1-6557-000CN	1
49	Spring, torsion	RB1-6558-020CN	1
51	Arm, sensor	RG5-1859-000CN	1
52	Photo-interrupter, IC, TLP1230	WG8-0291-000CN	1
87	Motor, pick-up (M5)	RH7-1350-000CN	1
103	PCA, paper pick-up	RG5-1860-000CN	1
501	Screw, tapping, pan head, M4 x 10	XB4-7401-007CN	6

## Registration frame assembly

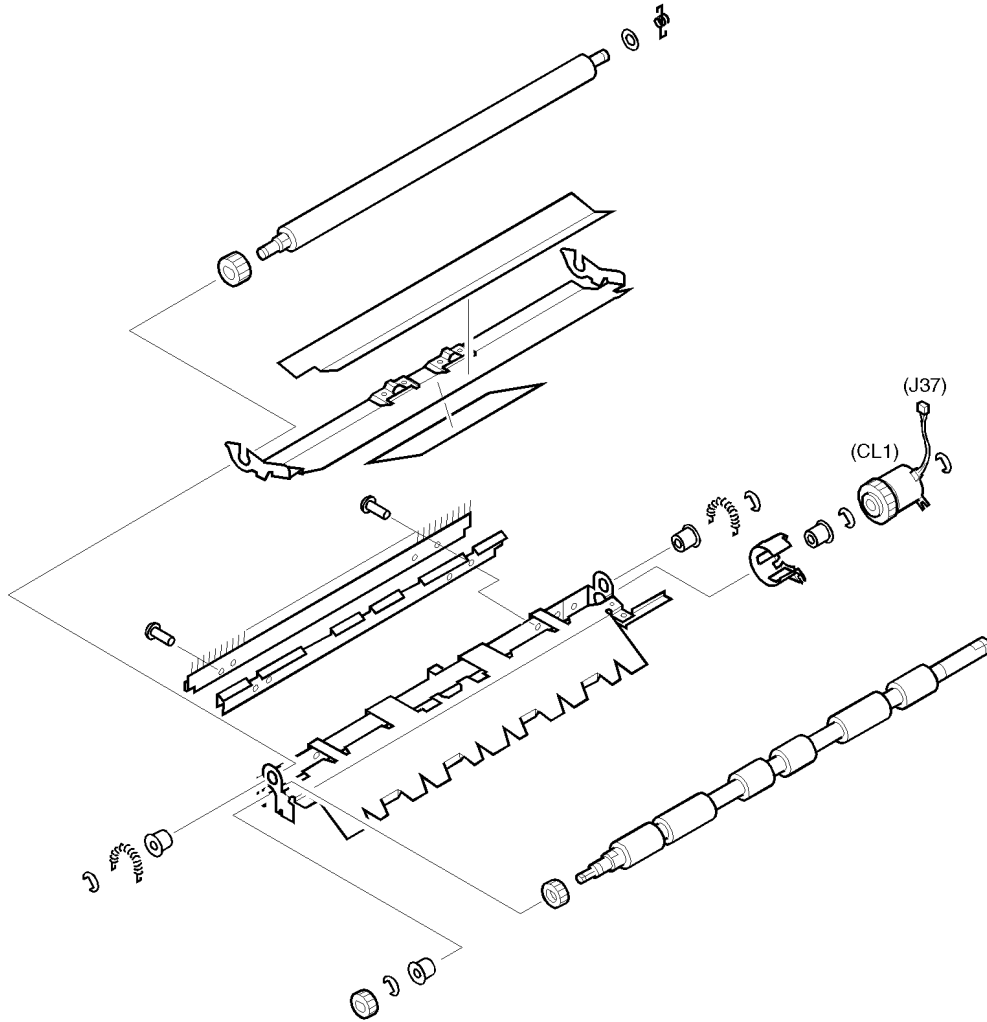


**Figure 231.** Registration frame assembly

**Table 66.** Registration frame assembly parts

Ref.	Description	Part number	Qty.
—	Registration frame assembly	RG5-3007-000CN	1
2	Spring, torsion	RB1-6409-000CN	1
3	Arm, sensor	RB1-6417-000CN	1
4	PCA, photo-interrupter, IC, TLP1240	WG8-5210-000CN	1
6	Cover, sensor	RB1-9586-000CN	1
7	PCA, photosensor	RG5-3032-000CN	1
8	PCA, photosensor	RG5-3079-000CN	1

## Registration roller assembly

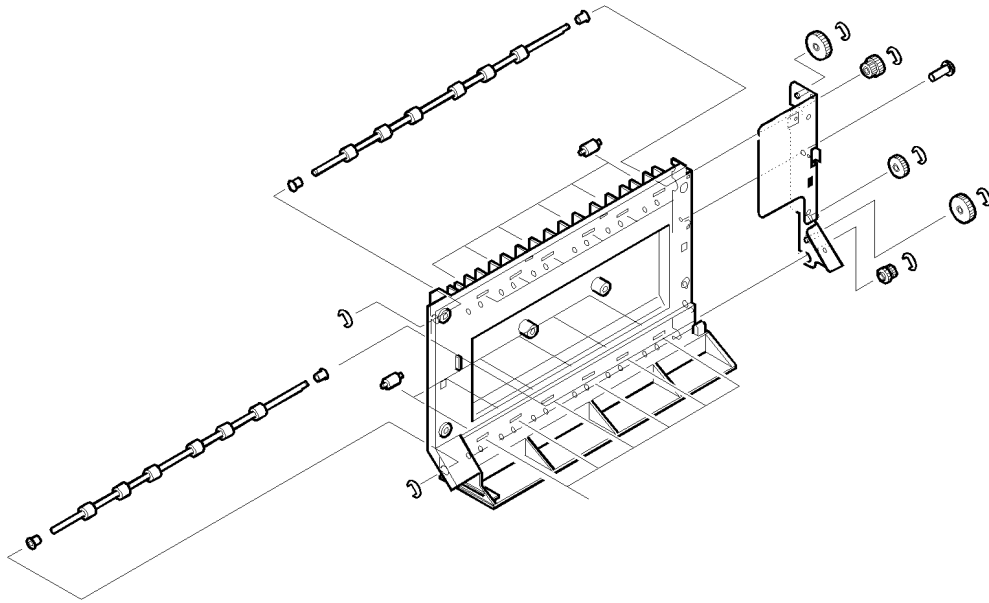


**Figure 232.** Registration roller assembly

**Table 67.** Registration roller assembly parts

Ref.	Description	Part number	Qty.
—	Registration roller assembly	RG5-3009-000CN	1

## Feeder assembly

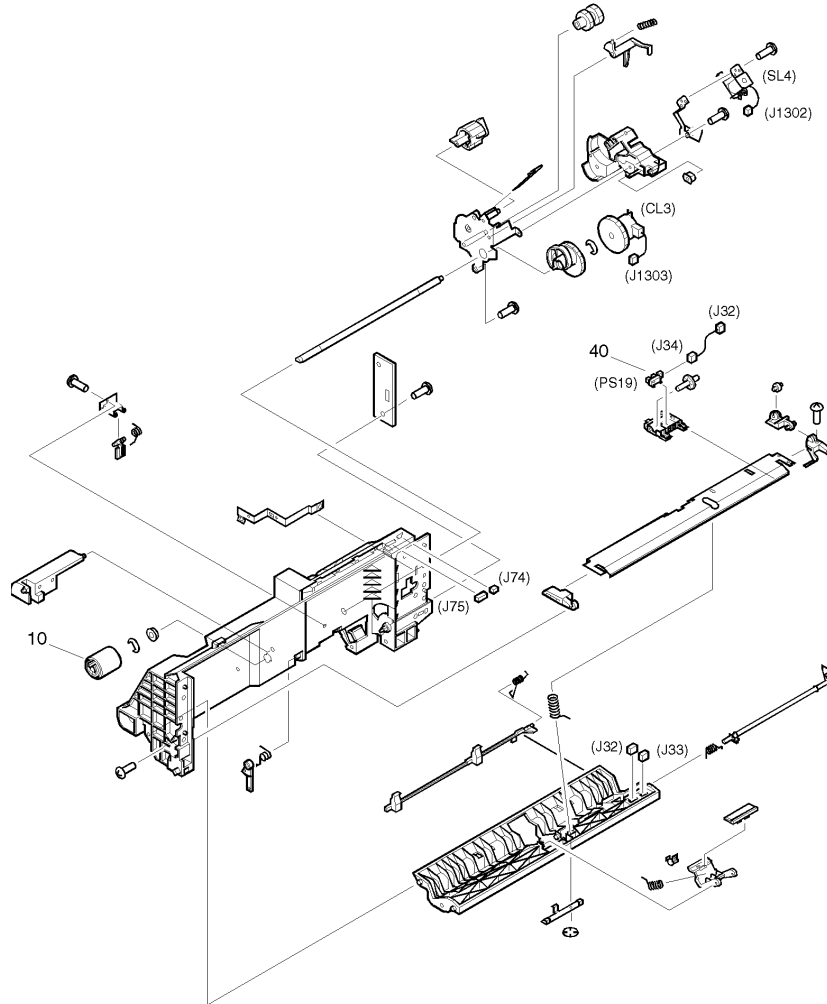


**Figure 233.** Feeder assembly

**Table 68.** Feeder assembly parts

Ref.	Description	Part number	Qty.
—	Feeder assembly	RG5-3059-000CN	1

## Tray 1 pick-up assembly

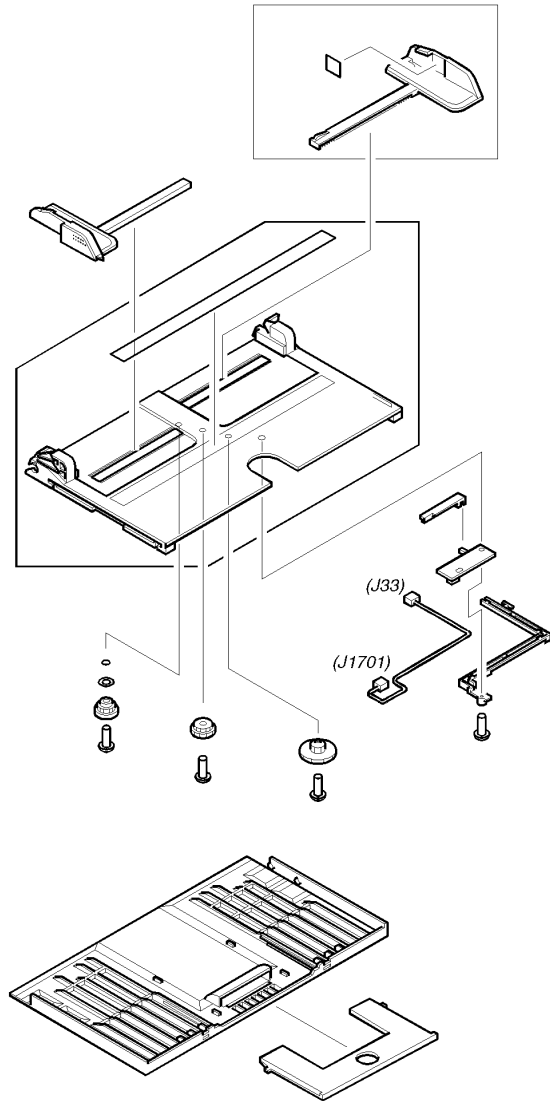


**Figure 234.** Tray 1 pick-up assembly

**Table 69.** Tray 1 pick-up assembly parts

Ref.	Description	Part number	Qty.
—	Tray 1 pick-up assembly	RG5-3054-000CN	1
10	Roller, tray 1 pick-up	RB1-9526-000CN	1
40	Photo-interrupter, IC, TLP1240	WG8-5210-000CN	1

## Tray 1 assembly

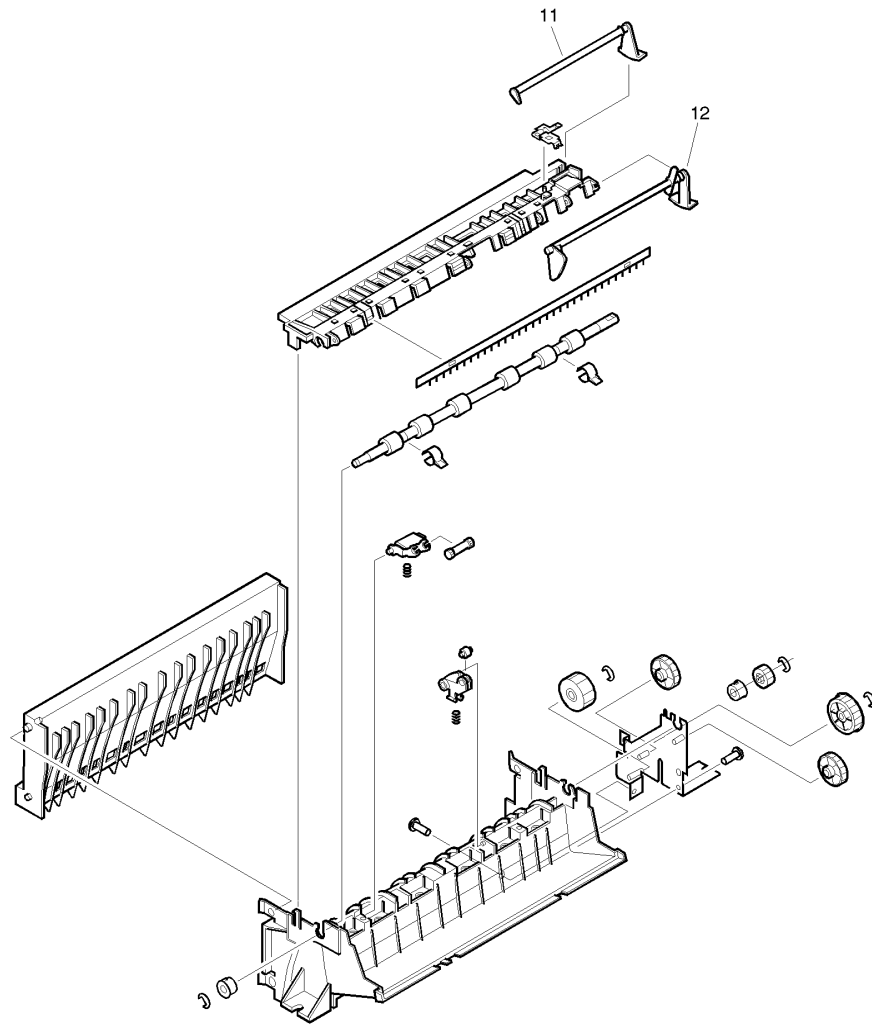


**Figure 235.** Tray 1 assembly

**Table 70.** Tray 1 assembly parts

Ref.	Description	Part number	Qty.
—	Tray 1 assembly	RG5-3134-000CN	1

## Delivery assembly

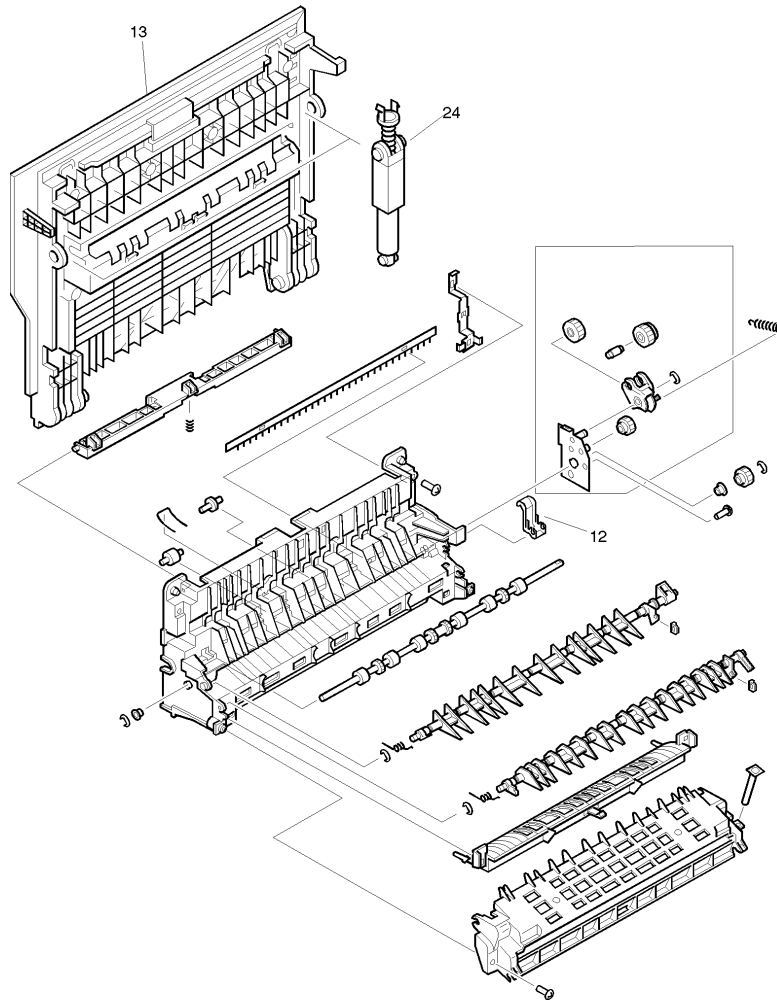


**Figure 236.** Delivery assembly

**Table 71.** Delivery assembly parts

Ref.	Description	Part number	Qty.
—	Delivery assembly	RG0-0110-000CN	1
11	Lever, paper sensing	RB1-6692-000CN	1
12	Lever, paper height	RA0-0112-000CN	1

## Delivery cover assembly



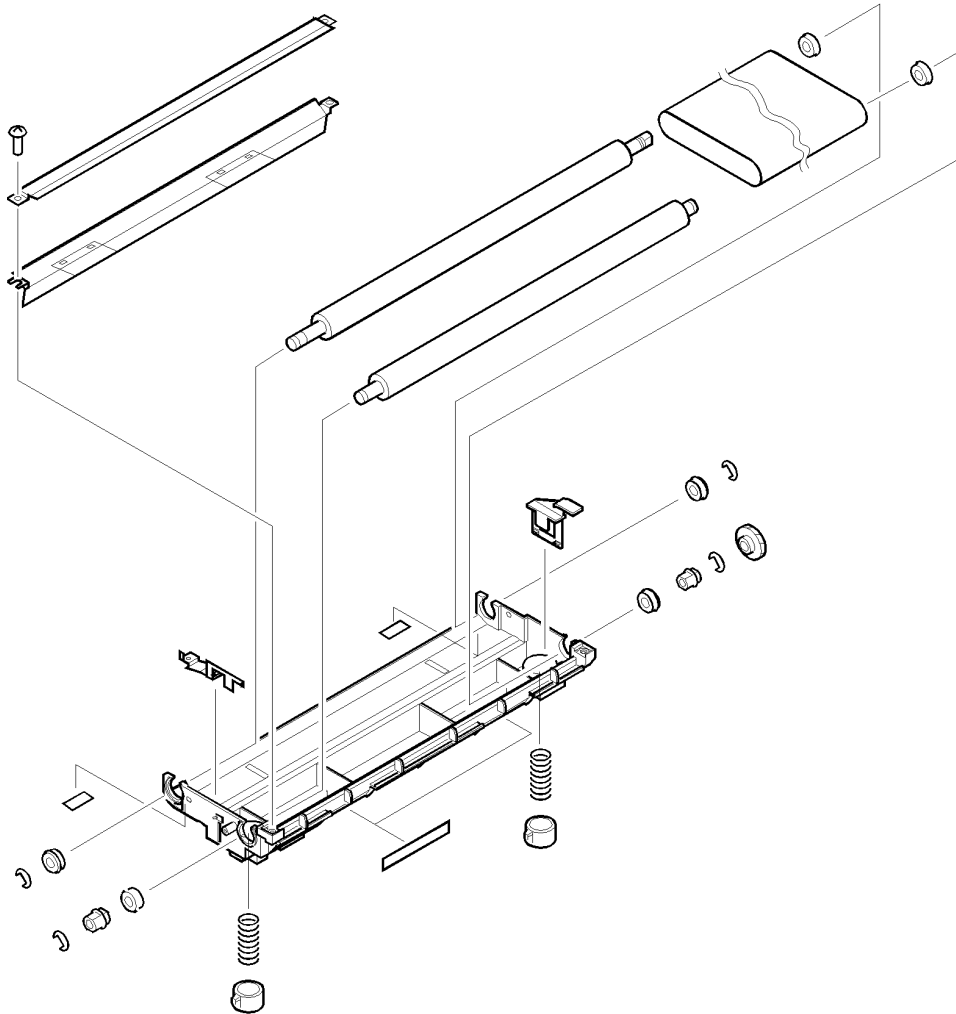
**Figure 237.** Delivery cover assembly

**Table 72.** Delivery cover assembly parts

Ref.	Description	Part number	Qty.
—	Delivery cover assembly	RG5-3108-000CN	1
12	Holder, flapper	RB1-9751-000CN	1
13	Cover, left upper	RB2-0057-000CN	1
24	Hinge, stopper (delivery)	RF5-2701-000CN	1



## Transfer belt assembly

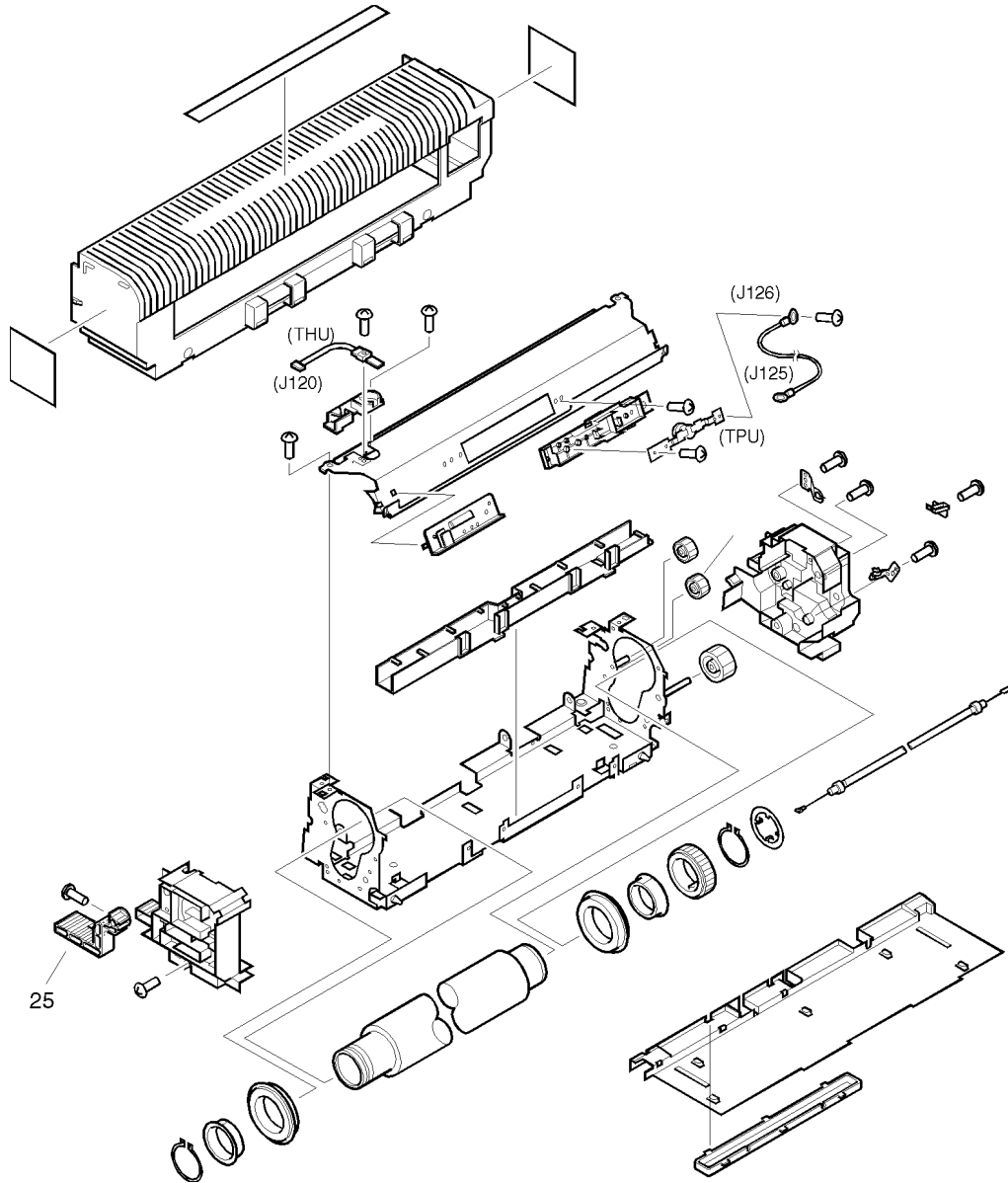


**Figure 238.** Transfer belt assembly

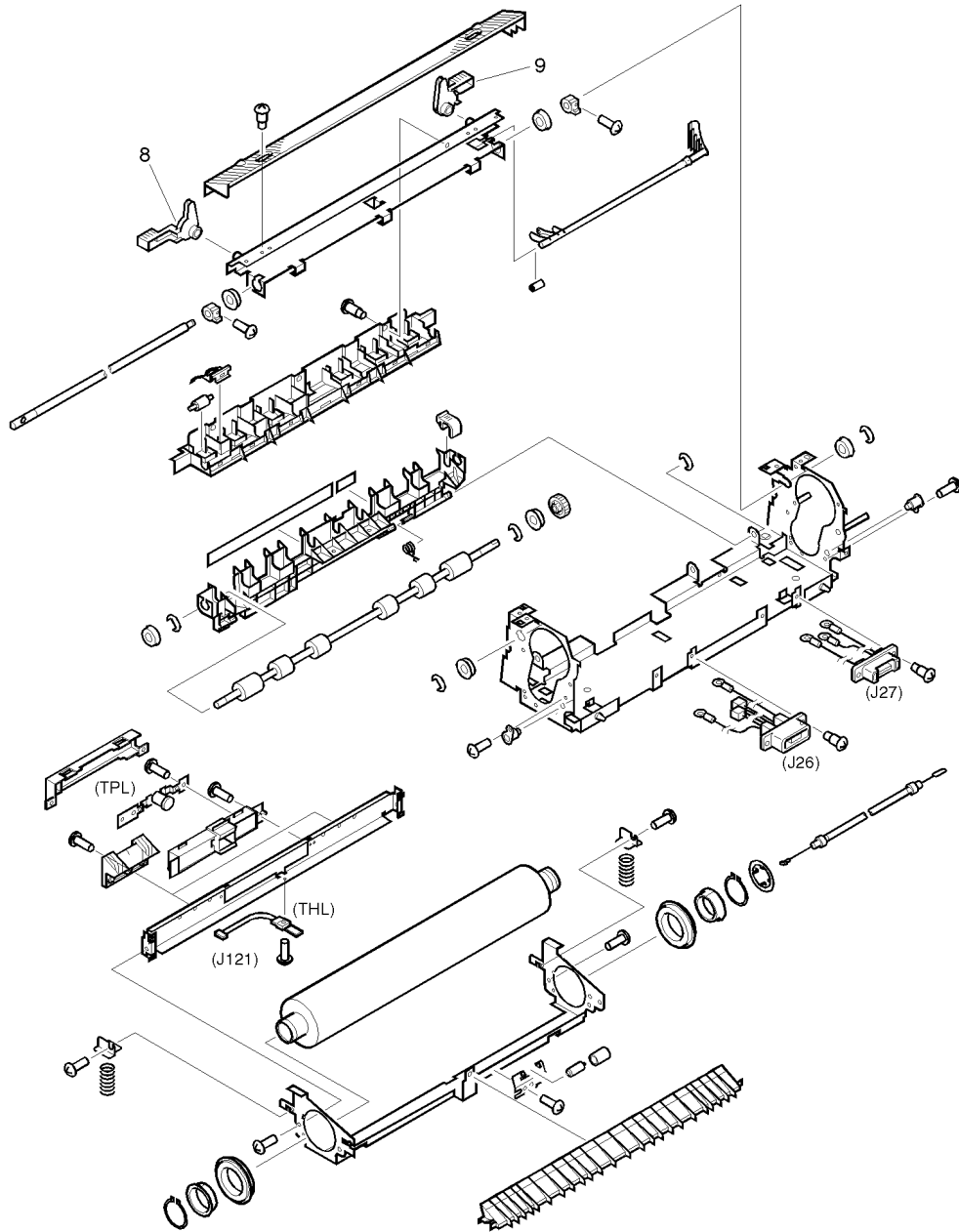
**Table 73.** Transfer belt assembly parts

Ref.	Description	Part number	Qty.
—	Transfer belt assembly	RG5-3047-000CN	1

# Fuser assembly



**Figure 239.** Fuser assembly (1 of 2)

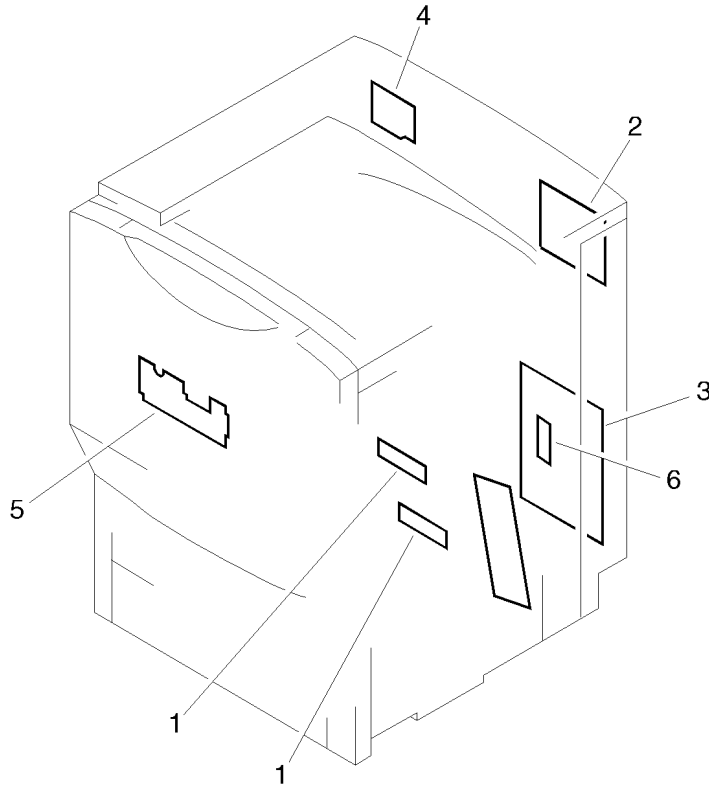


**Figure 240.** Fuser assembly (2 of 2)

**Table 74. Fuser assembly parts**

<b>Ref.</b>	<b>Description</b>	<b>Part number</b>	<b>Qty.</b>
—	Fuser assembly (120V) Fuser assembly (220V)	RG5-3060-000CN RG5-3061-000CN	1
8	Lever, holding, right	RB1-9704-000CN	1
9	Lever, holding, left	RB1-9705-000CN	1
25	Lever, release	RB1-9748-000CN	1

## PCA assembly location diagram

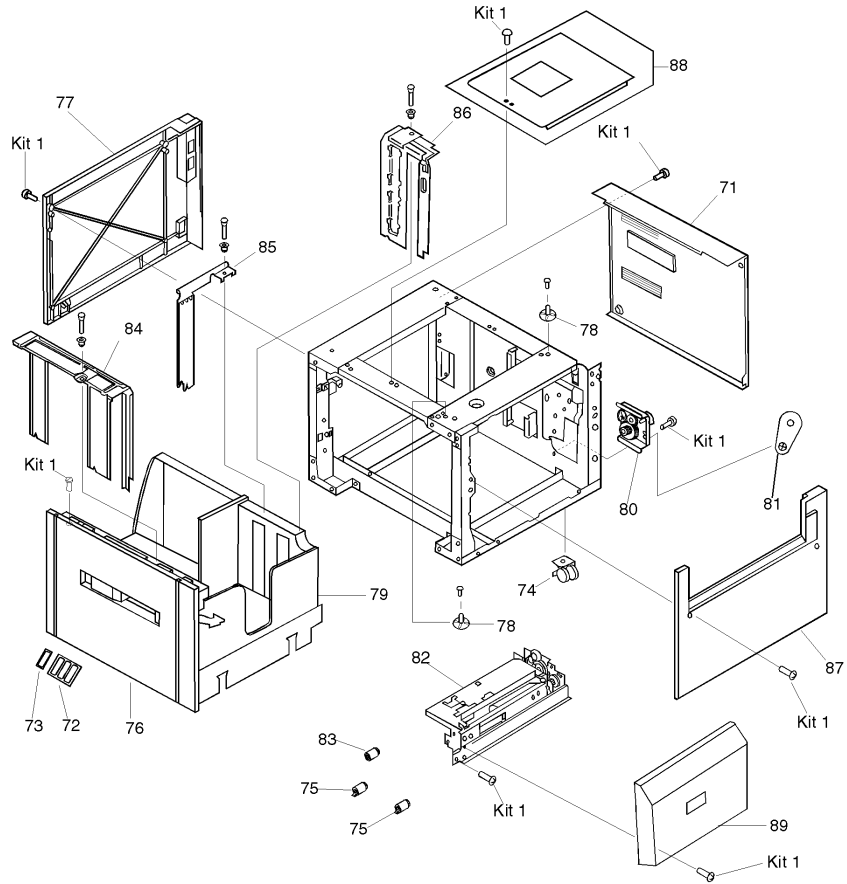


**Figure 241.** PCA assembly location diagram

**Table 75.** PCA assembly parts

Ref.	Description	Part number	Qty.
1	PCA, cassette-size sensing	RG5-1845-000CN	1
2	PCA, main relay	RG5-3036-000CN	1
3	PCA, controller board	RG5-3037-000CN	1
4	PCA, carousel motor (M1)	RG5-3084-000CN	1
5	PCA, subrelay	RG5-3085-000CN	1
6	PCA, tray 1	RG5-1884-000CN	1

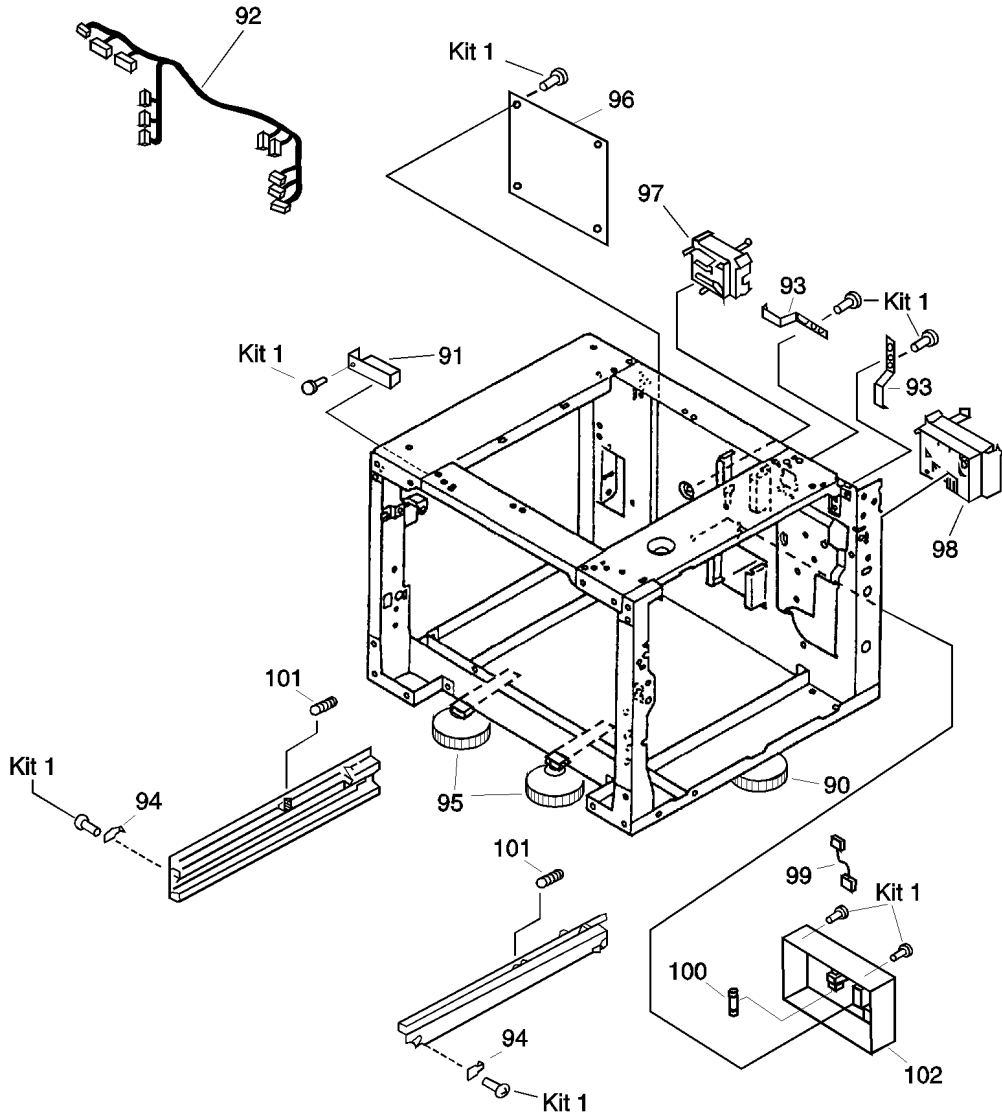
## 2,000-sheet input unit covers and doors



**Figure 242.** 2,000-sheet input unit covers and doors

**Table 76. 2,000-sheet input unit cover and door parts**

<b>Ref.</b>	<b>Description</b>	<b>Part number</b>	<b>Qty.</b>
71	Cover, back	RB2-2519-000CN	1
72	Cassette size labels	RS5-8611-000CN	1
73	Cassette size plate	RB1-6894-000CN	1
74	Casters	XZ9-0442-000CN	4
75	Feed and separation rollers	RF5-1834-000CN	2
76	Cover, front (with LED window)	RF5-2568-000CN	1
77	Cover, left	RF5-2646-000CN	1
78	Locating pin, metal (positioning)	RF5-2556-000CN	3
79	Tray 4	RG5-3845-000CN	1
80	Paper deck drive assembly	RG5-3851-000CN	1
81	Paper deck drive bushing	RS5-1399-000CN	1
82	Paper pick-up assembly	RG5-3843-000CN	1
83	Roller, pick-up	RF5-1835-000CN	1
84	Plate paper limit back	RG5-4201-000CN	1
85	Plate paper limit middle	RG5-3849-000CN	1
86	Plate paper reference front	RF5-3850-000CN	1
87	Cover, right	RB1-7832-020CN	1
88	Cover, top (label included)	RG5-2644-000CN	1
89	Vertical transfer unit (VTU)	RG5-3854-000CN	1
Kit 1	Screws kit (2,000-sheet input unit)	RY7-5044-000CN	1



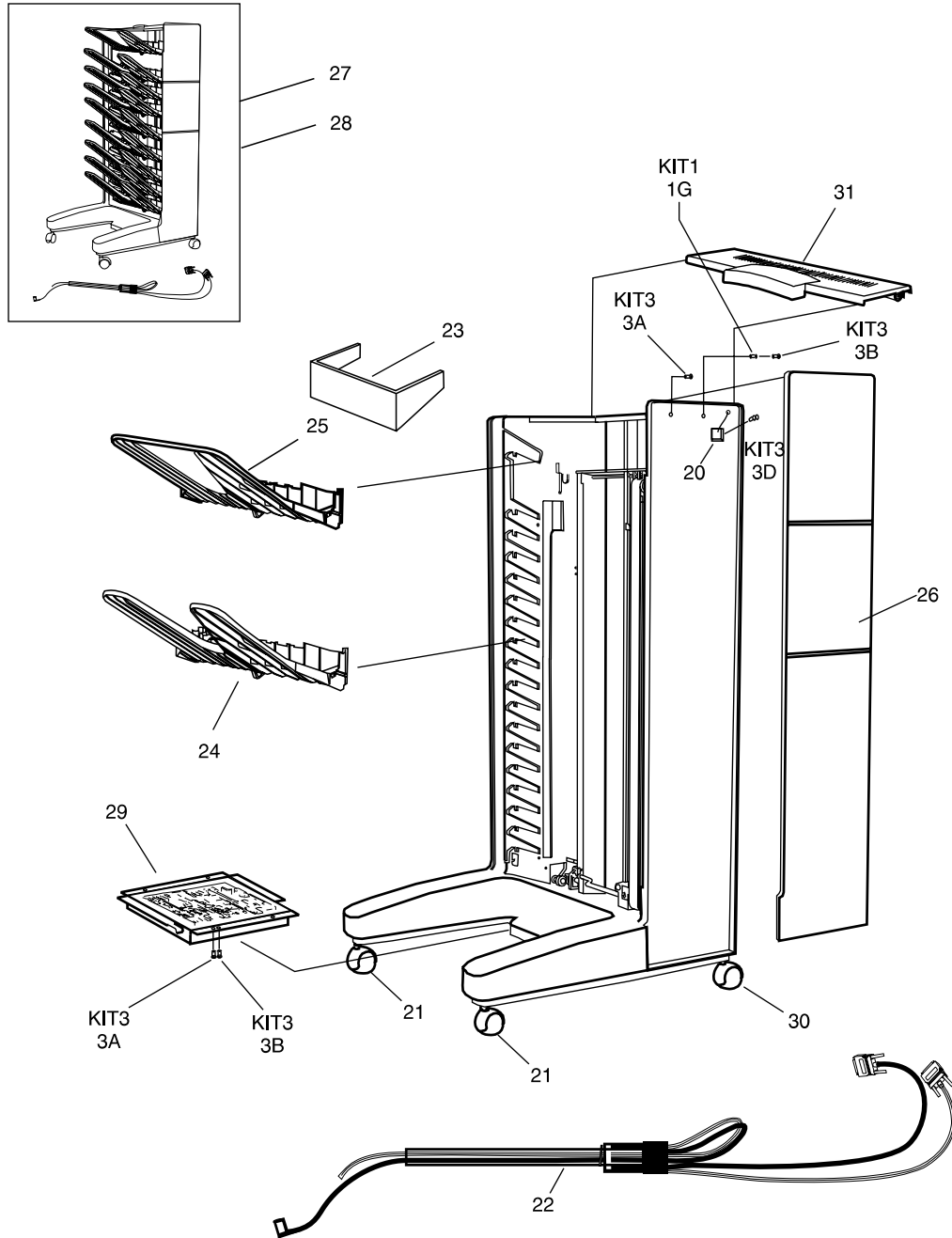
**Figure 243.** 2,000-sheet input unit internal components



**Table 77. 2,000-sheet input unit internal component parts**

<b>Ref.</b>	<b>Description</b>	<b>Part number</b>	<b>Qty.</b>
91	Front LED PCA with holder and cable	RG5-4204-000CN	1
92	Cable, main	RG5-3919-000CN	1
93	Metallic retaining spring (spring leaf)	RB1-7835-000CN	2
94	Metallic retaining tab (plate stop)	RB1-7677-000CN	2
95	Outriggers	RG5-4205-000CN	1
96	Paper deck PCA	RG5-3908-000CN	1
97	Paper quantity sensor PCA assembly	RG5-2166-000CN	1
98	Paper size sensor PCA assembly	RG5-2168-000CN	1
99	Power supply cable	RG5-3909-000CN	1
100	Power supply fuse 250V/3.15A	VD7-1893-151CN	1
101	Spring, tension	RS5-2561-000CN	2
102	Universal power supply assembly	RG5-4021-000CN	1
Kit 1	Screws kit (2,000-sheet input unit)	RY7-5044-000CN	1

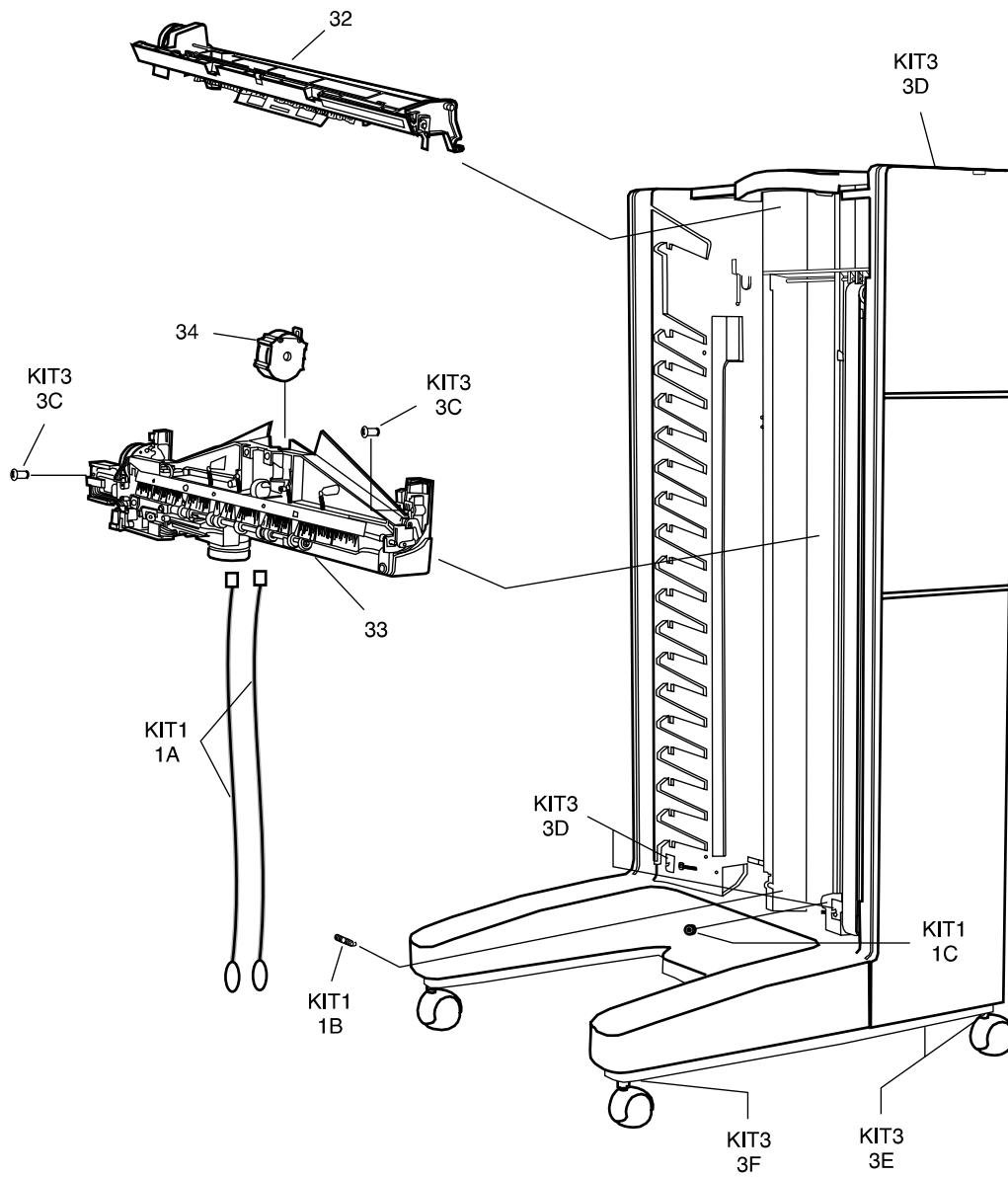
## Multi-bin mailbox components



**Figure 244.** Multi-bin mailbox components (1 of 3)

**Table 78. Multi-bin mailbox component parts (1 of 3)**

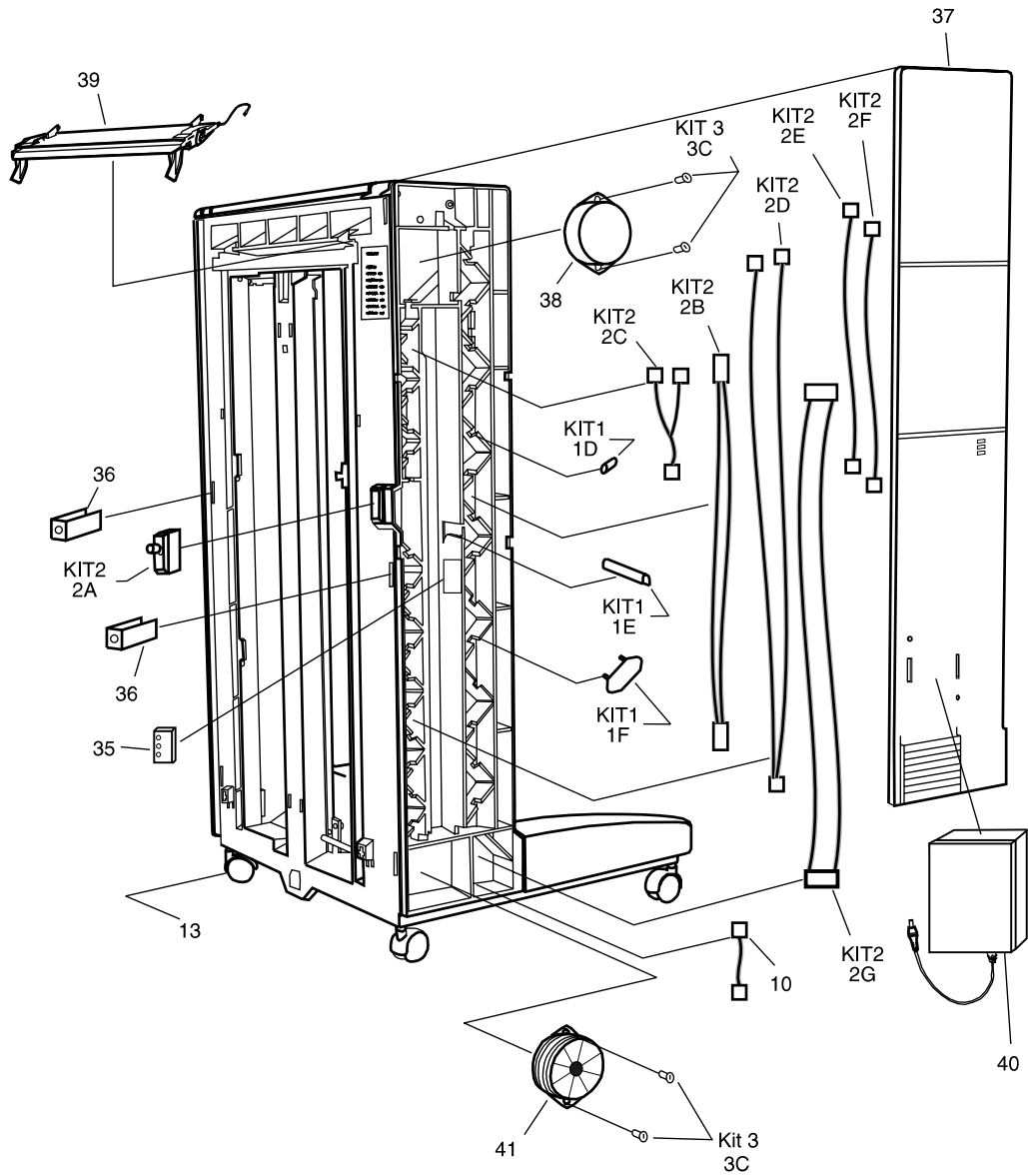
<b>Ref.</b>	<b>Description</b>	<b>Part number</b>	<b>Qty.</b>
20	User LED PCA (with cable)	C4785-60515	1
21	Adjustable fixed caster	C4785-60511	2
22	Attachment assembly (rod, bracket, cables)	C4785-60516	1
23	Blind cover	C4785-60503	1
24	Face-down bin	C4785-60502	1
25	Face-up bin	C3764-60505	1
26	Cover, front	C4785-60504	1
27	Exchange multi-bin mailbox assembly <b>Note:</b> You must have a 2,000-sheet input unit in order to install a multi-bin mailbox.	C4785-69500	1
28	Multi-bin mailbox assembly (product number C4785A) <b>Note:</b> You must have a 2,000-sheet input unit in order to install a multi-bin mailbox.	C4785-60500	1
29	Multi-bin mailbox controller (with metal box)	C4785-60508	1
30	Caster, fixed	C4785-60510	2
31	Cover, top	C3764-60555	1
Kit 1	Plastic parts 1G Spacer plastic	C4785-60519	1
Kit 3	Hardware 3A Screw, Torx 3B Screw, Torx, T20, M4 x 10 3D Screw, Torx, T20, M4 x 12	C4785-60521	1



**Figure 245.** Multi-bin mailbox components (2 of 3)

**Table 79. Multi-bin mailbox component parts (2 of 3)**

<b>Ref.</b>	<b>Description</b>	<b>Part number</b>	<b>Qty.</b>
32	Flipper assembly (with cable "request")	C4785-60509	1
33	Head assembly (with metallic tape)	C4785-60506	1
34	Metallic tape and housing assembly	C4785-60507	1
Kit 1	Plastic parts 1A Anti-curl string 1B Spring for anti-curl string 1C Pulley, small bottom	C4785-60519	1
Kit 3	Hardware 3C Screw, Torx, Tapping T20, M4 x 10 3D Screw, Torx, T20, M4 x 12 3E Screw, Torx, Tapping T10 3F Screw, Caster	C4785-60521	1



**Figure 246. Multi-bin mailbox components (3 of 3)**

**Table 80. Multi-bin mailbox component parts (3 of 3)**

<b>Ref.</b>	<b>Description</b>	<b>Part number</b>	<b>Qty.</b>
35	Diagnostic LED PCA (with cable)	C4785-60514	1
36	Attachment clip	C4785-60512	2
37	Back cover	C4785-60505	1
38	Delivery head position motor	C3764-60507	1
39	Input paper guide (nosepiece)	C3764-60561	1
40	Power supply	C4785-60501	1
41	Transport belt motor (with fan)	C4785-60518	1
Kit 1	Plastic parts 1D Cable holder round gasket 1E Flat cable holder edge 1F Flat cable holder	C4785-60519	1
Kit 2	Cables 2A Switch, interlock 2B Delivery head motor cable 2C Flipper sensor controller cable 2D Flipper encoder controller 2E Flipper motor controller 2F ESD cable 2G Delivery head assembly, flat cable	C4785-60520	1
Kit 3	Hardware 3C Screw, Torx, Tapping T20, M4 x 10	C4785-60521	1

## Numerical parts list

**Table 81. Numerical parts list**

Part number	Description	Figure	Ref.
5021-0337	PCL/PJL Technical Reference Package	—	—
5021-8956	<i>HP LaserJet Printer Family Paper Specification Guide</i>	—	—
5091-6456	<i>HP Peripherals Connectivity Solutions Guide</i>	—	—
5966-5171	<i>HP JetDirect Software Installation Guide</i> (English)	—	—
92215N	HP LocalTalk cable kit	—	—
92215S	Macintosh DIN-8 printer cable	—	—
C2934A	HP Color LaserJet transparencies (letter-sized), 50 sheets	—	—
C2936A	HP Color LaserJet transparencies (A4-sized), 50 sheets	—	—
C2946A	IEEE-1284 compliant parallel cable of 3 m (approximately 10 ft) with 25-pin male/micro 36-pin male "C" size connector	—	—
C2985A	EIO hard disk	—	—
C2986-60001	Hard disk, internal	—	—
C3763-60502	C-link cable (from formatter board to the 2,000-sheet input unit)	—	—
C3764-60505	Face-up bin	244	25
C3764-60507	Delivery head position motor	246	38
C3764-60555	Cover, top	244	31
C3764-60561	Input paper guide (nosepiece)	246	39
C3913A	64-MB synchronous DIMM	—	—
C3983-40001	Control panel overlay, English	—	—
C3983-40002	Control panel overlay, Traditional Chinese	—	—
C3983-40003	Control panel overlay, Korean	—	—
C3983-40004	Control panel overlay, Simplified Chinese	—	—
C3983-40005	Control panel overlay, Portuguese	—	—
C3983-40006	Control panel overlay, French	—	—



**Table 81. Numerical parts list (continued)**

<b>Part number</b>	<b>Description</b>	<b>Figure</b>	<b>Ref.</b>
C3983-40007	Control panel overlay, German	—	—
C3983-40008	Control panel overlay, Spanish	—	—
C3983-40009	Control panel overlay, Dutch	—	—
C3983-40010	Control panel overlay, Norwegian	—	—
C3983-40011	Control panel overlay, Swedish	—	—
C3983-40012	Control panel overlay, Finnish	—	—
C3983-40013	Control panel overlay, Danish	—	—
C3983-40014	Control panel overlay, Italian	—	—
C3983-40015	Control panel overlay, Russian	—	—
C3983-40016	Control panel overlay, Czech	—	—
C3989-60115	<i>HP Color LaserJet 8500, 8500N, 8500 DN Service and Support CD-ROM</i>	—	—
C3983-67902	<i>HP Color LaserJet 8500, 8500N, 8500 DN Self-Paced Training Kit (NTSC)</i>	—	—
C3893-67903	<i>HP Color LaserJet 8500, 8500N, 8500 DN Self-Paced Training Kit (PAL)</i>	—	—
C3983-67905	Formatter assembly	—	—
C3983-90919	<i>HP Color LaserJet 8500, 8500 N, 8500 DN Quick Reference Guide (English)</i>	—	—
C3989-90901	<i>HP Color LaserJet 8500, 8500 N, 8500 DN Getting Started Guide (English)</i>	—	—
C3989-90937	<i>HP Color LaserJet 8500, 8500 N, 8500 DN User's Guide (English)</i>	—	—
C4140A	4-MB synchronous DIMM <b>NOTE:</b> For all DIMM products, you must install DRAM DIMMs in synchronized pairs—for example, two 4-MB DIMMs.	—	—
C4141A	8-MB synchronous DIMM	—	—
C4142A	16-MB synchronous DIMM	—	—
C4143A	32-MB synchronous DIMM	—	—
C4149A	Black toner cartridge	—	—
C4150A	Cyan toner cartridge	—	—
C4151A	Magenta toner cartridge	—	—
C4152A	Yellow toner cartridge	—	—

**Table 81. Numerical parts list (continued)**

<b>Part number</b>	<b>Description</b>	<b>Figure</b>	<b>Ref.</b>
C4153A	Drum kit Imaging drum 2 air filters Hand wipe	—	—
C4154A	Transfer kit Transfer drum Transfer belt Cleaning roller Charcoal filter Hand wipe	—	—
C4155A	110-volt fuser kit Fuser 6 paper rollers Hand wipe	—	—
C4156A	220-volt fuser kit Fuser 6 paper rollers Hand wipe	—	—
C4179A	HP Color LaserJet soft gloss paper (letter-sized), 200 sheets	—	—
C4179B	HP Color LaserJet soft gloss paper (A4-sized), 200 sheets	—	—
C4781-60500	Power box	—	—
C4782-60501	Duplexer (product number C4782A)	—	—
C4782-69501	Exchange duplexer	—	—
C4785-60500	Multi-bin mailbox assembly (product number C4785A) <b>Note:</b> You must have a 2,000-sheet input tray in order to install a multi-bin mailbox.	244	28
C4785-60501	Power supply	246	40
C4785-60502	Face-down bin	244	24
C4785-60503	Blind cover	244	23
C4785-60504	Cover, front	244	26
C4785-60505	Back cover	246	37
C4785-60506	Head assembly (with metallic tape)	245	33
C4785-60507	Metallic tape and housing assembly	245	34
C4785-60508	Multi-bin mailbox controller (with metal box)	244	29
C4785-60509	Flipper assembly (with cable “request”)	245	32

**Table 81. Numerical parts list (continued)**

<b>Part number</b>	<b>Description</b>	<b>Figure</b>	<b>Ref.</b>
C4785-60510	Fixed casters	244	30
C4785-60511	Adjustable fixed caster	244	21
C4785-60512	Attachment clip	246	36
C4785-60513	Multi-bin mailbox, repackaging kit	—	—
C4785-60514	Diagnostic LED PCA (with cable)	246	35
C4785-60515	User LED PCA (with cable)	244	20
C4785-60516	Attachment assembly (rod, bracket, cables)	244	22
C4785-60518	Transport belt motor (with fan)	246	41
C4785-60519	Plastic parts 1A Anti-curl string 1B Spring for anti-curl string 1C Pulley, small bottom 1D Cable holder round gasket 1E Flat cable holder edge 1F Flat cable holder 1G Spacer plastic	245	Kit 1
C4785-60520	Cables 2A Switch, interlock 2B Delivery head motor cable 2C Flipper sensor controller cable 2D Flipper encoder controller 2E Flipper motor controller 2F ESD cable 2G Delivery head assembly, flat cable	246	Kit 2
C4785-60521	Hardware 3A Screw, Torx 3B Screw, Torx, T20, M4 x 10 3C Screw, Torx, Tapping T20, M4 x 10 3D Screw, Torx, T20, M4 x 12 3E Screw, Torx, Tapping T10 3F Screw, Caster	245	Kit 3
C4785-69500	Exchange multi-bin mailbox assembly <b>NOTE:</b> You must have a 2,000-sheet input unit in order to install a multi-bin mailbox.	244	27
C4785-70001	Multi-bin mailbox, short C-link cable adapter	—	—
C4787-60503	Multi-bin mailbox, shipping lock kit	—	—
J3110A	Ethernet 10Base-T	—	—
J3111A	Ethernet combo (10Base-T, BNC, and LocalTalk)	—	—
J3112A	Token Ring	—	—

**Table 81. Numerical parts list (continued)**

<b>Part number</b>	<b>Description</b>	<b>Figure</b>	<b>Ref.</b>
J3113-61003	PCA, 10/100Base-T	—	—
J3113A	10/100Base-TX	—	—
RA0-0008-000CN	Lever, shutter	214	3B
RA0-0026-000CN	Cover, inner 2	217	2
RA0-0027-000CN	Cover, inner 3	217	3
RA0-0065-000CN	Cover, left rear	215	6
RA0-0067-000CN	Cover, right rear	216	7
RA0-0068-000CN	Cover, hinge	214	8
RA0-0069-000CN	Cover, front right	214	9
RA0-0073-000CN	Stop, flip-up media	215	2D
RA0-0074-000CN	Cover, right rear lower corner	220	1
RA0-0078-000CN	Cover, auxiliary	215	20
RA0-0079-000CN	Support, cover	215	51A
RA0-0083-000CN	Cover, waste toner tray	217	10
RA0-0112-000CN	Lever, paper height	236	12
RB1-4497-000CN	Strap, front door support	214	3D
RB1-5153-000CN	Latch, roller action	214	3E
RB1-6409-000CN	Spring, torsion	231	2
RB1-6417-000CN	Arm, sensor	231	3
RB1-6463-000CN	Rod, power switch	220	5
RB1-6480-000CN	Cover, left lower	214	10
RB1-6484-000CN	Stopper, open/close	215216	6A, 16C
RB1-6485-000CN	Lever, left upper door	214	4B
	Lever, right lower cover	216	16D
	Lever, right upper door	216	17
RB1-6486-000CN	Spring, compression	216	16E
	Spring, left upper door lever	214	4C
	Spring, right lower door lever	216	22
RB1-6488-000CN	Roller, paper	216	16G
RB1-6491-000CN	Tray, face-up	214	11
RB1-6492-000CN	Cover, power switch	214	12

**Table 81. Numerical parts list (continued)**

<b>Part number</b>	<b>Description</b>	<b>Figure</b>	<b>Ref.</b>
RB1-6557-000CN	Flag, paper sensing	228	48
RB1-6558-020CN	Spring, torsion	228	49
RB1-6692-000CN	Lever, paper sensing	236	11
RB1-6894-000CN	Cassette size plate	242	73
RB1-6909-000CN	Spring, leaf	220	6
RB1-7677-000CN	Metallic retaining tab (plate stop)	243	94
RB1-7832-020CN	Cover, right	242	87
RB1-7835-000CN	Metallic retaining spring (spring leaf)	243	93
RB1-9401-000CN	Duct, rear lower air	218	4
RB1-9403-000CN	Cover, gear	221	7
RB1-9424-000CN	Gear, 11T	220	7
RB1-9526-000CN	Roller, tray 1 pick-up	234	10
RB1-9537-000CN	Cover, density sensor	216	32
RB1-9547-000CN	Cover, tray 1 side gear	216	46
RB1-9580-000CN	Lever, registration roller	221	13
RB1-9586-000CN	Cover, sensor	231	6
RB1-9617-000CN	Brush, cleaning	216	35A
RB1-9675-000CN	Spring, compression	220	4
RB1-9682-000CN	Duct	223	4
RB1-9704-000CN	Lever, holding, right	239	8
RB1-9705-000CN	Lever, holding, left	239	9
RB1-9748-000CN	Lever, release	239	25
RB1-9751-000CN	Holder, flapper	237	12
RB1-9789-000CN	Cover, carousel stop	218	11
RB1-9798-000CN	Spring, torsion	216	26
RB1-9804-000CN	Waste toner tray	217	5
RB1-9805-000CN	Cover, cable	220	9
RB1-9807-000CN	Filter, large air	215	1
RB1-9808-000CN	Filter, small air	215	19
RB1-9828-000CN	Mount, clutch	220	15
RB1-9836-000CN	Filter, charcoal	216	41

**Table 81. Numerical parts list (continued)**

<b>Part number</b>	<b>Description</b>	<b>Figure</b>	<b>Ref.</b>
RB1-9928-000CN	Media jam knob	217	7
RB1-9948-000CN	Cover, cable	222	3
RB1-9955-000CN	Gear, 14T	222	14
RB1-9956-000CN	Gear, 14T	222	15
RB2-0005-000CN	Rail, PCA	222	7D
RB2-0057-000CN	Cover, left upper	237	13
RB2-2519-000CN	Cover, back	242	71
RF0-0003-000CN	Latch, roller action	217	6
RF0-0012-000CN	Cover, fan	215	39
RF0-0013-000CN	Cover, inner 4	217	4
RF5-1396-000CN	Rail, tray 3	223	32
RF5-1484-000CN	Plate, end	226, 227	26
RF5-1834-000CN	Feed and separation rollers	242	75
RF5-1834-000CN	Roller, feed	228	20
RF5-1835-000CN	Roller, pick-up	228, 242	21, 83
RF5-1995-000CN	Cover, right subassembly	216	31
RF5-2025-000CN	Holder, fan	223	3
RF5-2036-000CN	Plate, duct mount	218	3
RF5-2556-000CN	Locating pin, metal (positioning)	242	78
RF5-2568-000CN	Cover, front (with LED window)	242	76
RF5-2646-000CN	Left cover	242	77
RF5-2701-000CN	Hinge, stopper (delivery)	237	24
RF5-3850-000CN	Plate paper reference front	242	86
RG0-0017-000CN	Cover, rear fan housing	215	51
RG0-0104-000CN	Cover assembly, inner left	217	1
RG0-0110-000CN	Delivery assembly	236	—
RG0-0111-000CN	Cover assembly, top	215	2
RG0-0112-000CN	Cover assembly, front	214	3
RG0-0113-000CN	Cover assembly, left upper	214	4
RG0-0115-000CN	Cover assembly, rear	215	5
RG5-1845-000CN	PCA, cassette-size sensing	241	1

**Table 81. Numerical parts list (continued)**

<b>Part number</b>	<b>Description</b>	<b>Figure</b>	<b>Ref.</b>
RG5-1851-000CN	Tray rail assembly	221	3
RG5-1859-000CN	Arm, sensor	228	51
RG5-1860-000CN	PCA, paper pick-up	228	103
RG5-1884-000CN	PCA, tray 1	241	6
RG5-2166-000CN	Paper quantity sensor PCA assembly	243	97
RG5-2168-000CN	Paper size sensor PCA assembly	243	98
RG5-2644-000CN	Cover, top (label included)	242	88
RG5-3007-000CN	Registration frame assembly	231	—
RG5-3008-000CN	Transfer mount assembly	223	36
RG5-3009-000CN	Registration roller assembly	232	—
RG5-3010-000CN	Transfer swing assembly	221	10
RG5-3022-000CN	Face-up solenoid assembly	218	140
RG5-3023-000CN	Shield case assembly	222	7
RG5-3026-000CN	PCA, high-voltage converter 1	220	20
RG5-3031-000CN	Connector holder assembly	218	15
RG5-3032-000CN	PCA, photosensor	231	7
RG5-3033-000CN	Developing rotary	224	36
RG5-3034-000CN	Sensor assembly, color toner	220	8
RG5-3036-000CN	PCA, main relay	241	2
RG5-3037-000CN	PCA, controller board	241	3
RG5-3039-000CN	Transfer drum	222	17
RG5-3044-000CN	Transfer drum contact assembly	220	2
RG5-3045-000CN	Lever assembly, pressure	219	7
RG5-3046-000CN	Lever assembly, transfer drum	219	6
RG5-3047-000CN	Transfer belt assembly	238	—
RG5-3053-000CN	Carousel stop assembly	218	6
RG5-3054-000CN	Tray 1 pick-up assembly	234	—
RG5-3057-000CN	Density sensor assembly	216	35
RG5-3059-000CN	Feeder assembly	233	—
RG5-3060-000CN	Fuser assembly (120V)	239	—
RG5-3061-000CN	Fuser assembly (220V)	239	—

**Table 81. Numerical parts list (continued)**

<b>Part number</b>	<b>Description</b>	<b>Figure</b>	<b>Ref.</b>
RG5-3065-000CN	Drum/cartridge drive assembly	224	—
RG5-3066-000CN	Main drive assembly	221	18
RG5-3067-000CN	Delivery drive assembly	225	—
RG5-3079-000CN	PCA, photosensor	231	8
RG5-3080-000CN	PCA, photosensor	218	2
RG5-3084-000CN	PCA, carousel motor (M1)	241	4
RG5-3085-000CN	PCA, subrelay	241	5
RG5-3087-000CN	Lever assembly, black cartridge	219	10
RG5-3089-000CN	Cassette crossmember assembly	223	30
RG5-3096-000CN	Cover assembly, right lower	216	16
RG5-3097-000CN	Cable, main	218	16
RG5-3104-000CN	Cable, delivery	221	20
RG5-3108-000CN	Delivery cover assembly	237	—
RG5-3111-000CN	Transfer drum cleaner holder assembly	223	21
RG5-3131-000CN	Sensor slider assembly	223	37
RG5-3132-000CN	Paper pick-up assembly	228	—
RG5-3134-000CN	Tray 1 assembly	235	—
RG5-3144-000CN	Cable, sensor	218	18
RG5-3147-000CN	Cable, delivery connector	221	12
RG5-3843-000CN	Paper pick-up assembly	242	82
RG5-3845-000CN	Tray 4	242	79
RG5-3849-000CN	Plate paper limit middle	242	85
RG5-3851-000CN	Paper deck drive assembly	242	80
RG5-3854-000CN	Vertical transfer unit (VTU)	242	89
RG5-3908-000CN	Paper deck PCA	243	96
RG5-3909-000CN	Power supply cable	243	99
RG5-3919-000CN	Cable, main	243	92
RG5-3921-000CN	Cable, DC power	218	19
RG5-3922-000CN	Cable, power signal	218	20
RG5-3923-000CN	Cable, carousel	221	6
RG5-3934-000CN	Sensor assembly, toner waste	222	24



**Table 81. Numerical parts list (continued)**

<b>Part number</b>	<b>Description</b>	<b>Figure</b>	<b>Ref.</b>
RG5-3936-000CN	Laser/scanner unit	222	18
RG5-3942-000CN	Cable, main motor	221	5
RG5-3943-000CN	PCA, high-voltage converter 2	220	21
RG5-3961-000CN	PCA, cartridge release lever	218	21
RG5-3962-000CN	Hinge, stopper (tray 1 delivery assembly)	216	54
RG5-3966-000CN	Separation discharge high-voltage converter PCA	220	30
RG5-3973-000CN	Static charge eliminator assembly	223	14
RG5-3975-000CN	Cleaning roller assembly	223	15
RG5-3980-000CN	Preconditioning exposure LED assembly	216	36
RG5-3992-000CN	PCA, fusing delivery sensor	218	8
RG5-4021-000CN	Universal power supply assembly	243	102
RG5-4201-000CN	Plate paper limit back	242	84
RG5-4204-000CN	Front LED PCA with holder and cable	243	91
RG5-4205-000CN	Outriggers	243	95
RH3-0211-000CN	High-voltage converter 1	220	24
RH3-0228-000CN	High-voltage converter 2	220	25
RH3-0234-000CN	Separation discharge high-voltage converter	220	39
RH3-2185-000CN	Power supply assembly (110V)	218	25
RH3-2187-000CN	Power supply assembly (220V)	218	25
RH7-1323-000CN	Motor, main (M4)	221	21
RH7-1325-000CN	Motor, carousel (M1)	220	26
RH7-1328-000CN	Motor, cartridge (M3)	224	23
RH7-1330-000CN	Fan 1 (FM1)	223	8
RH7-1350-000CN	Motor, pick-up (M5)	228	87
RH7-1373-000CN	Fan 2 (FM2)	223	7
RH7-1393-000CN	Fan 3 (FM3)	216	42
RH7-5168-000CN	Clutch, transfer belt press (CL4)	220	27
RS5-1119-000CN	Bushing	219	8
RS5-1317-000CN	Bushing	219	29, 30
RS5-1319-000CN	Bushing	223	19

**Table 81. Numerical parts list (continued)**

<b>Part number</b>	<b>Description</b>	<b>Figure</b>	<b>Ref.</b>
RS5-1399-000CN	Bushing, paper deck drive	242	81
RS5-2465-000CN	Spring, tension	220	28
RS5-2561-000CN	Spring, tension	243	101
RS5-2697-000CN	Spring, torsion	223	20
RS5-2698-000CN	Spring, torsion	223	16
RS5-2719-000CN	Spring, compression	215	51B
RS5-8380-000CN	Label, "CAUTION"	217	4A
RS5-8611-000CN	Cassette size labels	242	72
RY7-5044-000CN	Screw kit (2,000-sheet input unit)	242, 243	Kit 1
VD7-1893-151CN	Power supply fuse 250V/3.15A	243	100
WC4-5136-000CN	Switch, black toner cartridge (SW644)	219	22
WC4-5150-000CN	Switch, toner cartridge cover (SW672)	218	30
WG8-0291-000CN	Photo-interrupter, IC, TLP1230	228	52
WG8-5210-000CN	Photo-interrupter, IC, TLP1240	219, 231, 234	23, 4, 40
WG8-5362-000CN	Photo-interrupter, IC, TLP1241	221	24
XA9-0836-000CN	Screw, TP, M3 x 6, quantity 10	—	—
XA9-0849-000CN	Screw, RS, M3 x 6	221	26
XA9-0926-000CN	Screw, TP, M4 x 8, quantity 10	—	—
XA9-0940-000CN	Screw, w/washer, M4 x 12, quantity 4	222	37
XA9-0951-000CN	Screw, w/washer, M3 x 8, quantity 10	—	—
XB4-7401-007CN	Screw, tapping, pan head, M4 x 10	228	501
XD2-1100-502CN	Ring, E	220	501
XD2-1100-642CN	Ring, E	219	501
XZ9-0442-000CN	Casters	242	74

## Alphabetical parts list

**Table 82. Alphabetical parts list**

Description	Part number	Figure	Ref.
10/100Base-TX	J3113A	—	—
110-volt fuser kit Fuser 6 paper rollers Hand wipe	C4155A	—	—
220-volt fuser kit Fuser 6 paper rollers Hand wipe	C4156A	—	—
4-MB synchronous DIMM <b>NOTE:</b> For all DIMM products, you must install DRAM DIMMs in synchronized pairs—for example, two 4-MB DIMMs.	C4140A	—	—
8-MB synchronous DIMM	C4141A	—	—
16-MB synchronous DIMM	C4142A	—	—
32-MB synchronous DIMM	C4143A	—	—
64-MB synchronous DIMM	C3913A	—	—
Adjustable fixed caster	C4785-60511	244	21
Arm, sensor	RB1-6417-000CN	231	3
	RG5-1859-000CN	228	51
Attachment assembly (rod, bracket, cables)	C4785-60516	244	22
Attachment clip	C4785-60512	246	36
Black toner cartridge	C4149A	—	—
Blind cover	C4785-60503	244	23
Brush, cleaning	RB1-9617-000CN	216	35A
Bushing	RS5-1119-000CN	219	8
	RS5-1317-000CN	219	29, 30
	RS5-1319-000CN	223	19
Cable, C-link (from formatter board to the 2,000-sheet input unit)	C3763-60502	—	—
Cable, carousel	RG5-3923-000CN	221	6

**Table 82. Alphabetical parts list (continued)**

<b>Description</b>	<b>Part number</b>	<b>Figure</b>	<b>Ref.</b>
Cable, DC power	RG5-3921-000CN	218	19
Cable, delivery	RG5-3104-000CN	221	20
Cable, delivery connector	RG5-3147-000CN	221	12
Cable, main	RG5-3097-000CN	218	16
	RG5-3919-000CN	243	92
Cable, main motor	RG5-3942-000CN	221	5
Cable, power signal	RG5-3922-000CN	218	20
Cable, sensor	RG5-3144-000CN	218	18
Cables	C4785-60520	246	Kit 2
2A Switch, interlock			
2B Delivery head motor cable			
2C Flipper sensor controller cable			
2D Flipper encoder controller			
2E Flipper motor controller			
2F ESD cable			
2G Delivery head assembly, flat cable			
Carousel stop assembly	RG5-3053-000CN	218	6
Cassette crossmember assembly	RG5-3089-000CN	223	30
Cassette size labels	RS5-8611-000CN	242	72
Cassette size plate	RB1-6894-000CN	242	73
Castors	XZ9-0442-000CN	242	74
Castors, fixed	C4785-60510	244	30
Cleaning roller assembly	RG5-3975-000CN	223	15
Clutch, transfer belt press (CL4)	RH7-5168-000CN	220	27
Connector holder assembly	RG5-3031-000CN	218	15
Control panel overlay, Czech	C3983-40016	—	—
Control panel overlay, Danish	C3983-40013	—	—
Control panel overlay, Dutch	C3983-40009	—	—
Control panel overlay, English	C3983-40001	—	—
Control panel overlay, Finnish	C3983-40012	—	—
Control panel overlay, French	C3983-40006	—	—
Control panel overlay, German	C3983-40007	—	—
Control panel overlay, Italian	C3983-40014	—	—

**Table 82. Alphabetical parts list (continued)**

<b>Description</b>	<b>Part number</b>	<b>Figure</b>	<b>Ref.</b>
Control panel overlay, Korean	C3983-40003	—	—
Control panel overlay, Norwegian	C3983-40010	—	—
Control panel overlay, Portuguese	C3983-40005	—	—
Control panel overlay, Russian	C3983-40015	—	—
Control panel overlay, Simplified Chinese	C3983-40004	—	—
Control panel overlay, Spanish	C3983-40008	—	—
Control panel overlay, Swedish	C3983-40011	—	—
Control panel overlay, Traditional Chinese	C3983-40002	—	—
Cover assembly, front	RG0-0112-000CN	214	3
Cover assembly, inner left	RG0-0104-000CN	217	1
Cover assembly, left upper	RG0-0113-000CN	214	4
Cover assembly, rear	RG0-0115-000CN	215	5
Cover assembly, right lower	RG5-3096-000CN	216	16
Cover assembly, top	RG0-0111-000CN	215	2
Cover, auxiliary	RA0-0078-000CN	215	20
Cover, back	C4785-60505	246	37
	RB2-2519-000CN	242	71
Cover, cable	RB1-9805-000CN	220	9
	RB1-9948-000CN	222	3
Cover, carousel stop	RB1-9789-000CN	218	11
Cover, density sensor	RB1-9537-000CN	216	32
Cover, fan	RF0-0012-000CN	215	39
Cover, front	C4785-60504	244	26
Cover, front right	RA0-0069-000CN	214	9
Cover, front (with LED window)	RF5-2568-000CN	242	76
Cover, gear	RB1-9403-000CN	221	7
Cover, hinge	RA0-0068-000CN	214	8
Cover, inner 2	RA0-0026-000CN	217	2
Cover, inner 3	RA0-0027-000CN	217	3
Cover, inner 4	RF0-0013-000CN	217	4
Cover, left	RF5-2646-000CN	242	77

**Table 82. Alphabetical parts list (continued)**

<b>Description</b>	<b>Part number</b>	<b>Figure</b>	<b>Ref.</b>
Cover, left lower	RB1-6480-000CN	214	10
Cover, left rear	RA0-0065-000CN	215	6
Cover, left upper	RB2-0057-000CN	237	13
Cover, power switch	RB1-6492-000CN	214	12
Cover, rear fan housing	RG0-0017-000CN	215	51
Cover, right	RB1-7832-020CN	242	87
Cover, right rear	RA0-0067-000CN	216	7
Cover, right rear lower corner	RA0-0074-000CN	220	1
Cover, right subassembly	RF5-1995-000CN	216	31
Cover, sensor	RB1-9586-000CN	231	6
Cover, top	C3764-60555	244	31
Cover, top (label included)	RG5-2644-000CN	242	88
Cover, tray 1 side gear	RB1-9547-000CN	216	46
Cover, waste toner tray	RA0-0083-000CN	217	10
Cyan toner cartridge	C4150A	—	—
Delivery assembly	RG0-0110-000CN	236	—
Delivery cover assembly	RG5-3108-000CN	237	—
Delivery drive assembly	RG5-3067-000CN	225	—
Delivery head position motor	C3764-60507	246	38
Density sensor assembly	RG5-3057-000CN	216	35
Developing rotary	RG5-3033-000CN	224	36
Diagnostic LED PCA (with cable)	C4785-60514	246	35
Drum kit Imaging drum 2 air filters Hand wipe	C4153A	—	—
Drum/cartridge drive assembly	RG5-3065-000CN	224	—
Duct	RB1-9682-000CN	223	4
Duct, rear lower air	RB1-9401-000CN	218	4
Duplexer (product number C4782A)	C4782-60501	—	—
EIO hard disk	C2985A	—	—
Ethernet 10Base-T	J3110A	—	—

**Table 82. Alphabetical parts list (continued)**

<b>Description</b>	<b>Part number</b>	<b>Figure</b>	<b>Ref.</b>
Ethernet combo (10Base-T, BNC, and LocalTalk)	J3111A	—	—
Exchange duplexer	C4782-69501		
Exchange multi-bin mailbox assembly	C4785-69500	244	27
Face-down bin	C4785-60502	244	24
Face-up bin	C3764-60505	244	25
Face-up solenoid assembly	RG5-3022-000CN	218	140
Fan 1 (FM1)	RH7-1330-000CN	223	8
Fan 2 (FM2)	RH7-1373-000CN	223	7
Fan 3 (FM3)	RH7-1393-000CN	216	42
Feed and separation rollers	RF5-1834-000CN	242	75
Feeder assembly	RG5-3059-000CN	233	—
Filter, charcoal	RB1-9836-000CN	216	41
Filter, large air	RB1-9807-000CN	215	1
Filter, small air	RB1-9808-000CN	215	19
Flag, paper sensing	RB1-6557-000CN	228	48
Flipper assembly (with cable “request”)	C4785-60509	245	32
Formatter assembly	C3983-67905	—	—
Front LED PCA with holder and cable	RG5-4204-000CN	243	91
Fuser assembly (120V)	RG5-3060-000CN	239	—
Fuser assembly (220V)	RG5-3061-000CN	239	—
Gear, 11T	RB1-9424-000CN	220	7
Gear, 14T	RB1-9955-000CN	222	14
	RB1-9956-000CN	222	15
Hard disk, internal	C2986-60001	—	—
Hardware 3A Screw, Torx 3B Screw, Torx, T20, M4 x 10 3C Screw, Torx, Tapping T20, M4 x 10 3D Screw, Torx, T20, M4 x 12 3E Screw, Torx, Tapping T10 3F Screw, Caster	C4785-60521	245	Kit 3
Head assembly (with metallic tape)	C4785-60506	245	33
High-voltage converter 1	RH3-0211-000CN	220	24

**Table 82. Alphabetical parts list (continued)**

<b>Description</b>	<b>Part number</b>	<b>Figure</b>	<b>Ref.</b>
High-voltage converter 2	RH3-0228-000CN	220	25
Hinge, stopper (delivery)	RF5-2701-000CN	237	24
Hinge, stopper (tray 1 delivery assembly)	RG5-3962-000CN	216	54
Holder, fan	RF5-2025-000CN	223	3
Holder, flapper	RB1-9751-000CN	237	12
<i>HP Color LaserJet 8500, 8500 N, 8500 DN Getting Started Guide (English)</i>	C3989-90901	—	—
<i>HP Color LaserJet 8500, 8500 N, 8500 DN Quick Reference Guide (English)</i>	C3983-90919	—	—
<i>HP Color LaserJet 8500, 8500N, 8500 DN Self-Paced Training Kit (NTSC)</i>	C3983-67902	—	—
<i>HP Color LaserJet 8500, 8500N, 8500 DN Self-Paced Training Kit (PAL)</i>	C3893-67903	—	—
<i>HP Color LaserJet 8500, 8500N, 8500 DN Service and Support CD-ROM</i>	C3989-60115	—	—
<i>HP Color LaserJet 8500, 8500 N, 8500 DN User's Guide (English)</i>	C3989-90937	—	—
HP Color LaserJet soft gloss paper (A4-sized), 200 sheets	C4179B	—	—
HP Color LaserJet soft gloss paper (letter-sized), 200 sheets	C4179A	—	—
HP Color LaserJet transparencies (A4-sized), 50 sheets	C2936A	—	—
HP Color LaserJet transparencies (letter-sized), 50 sheets	C2934A	—	—
<i>HP JetDirect Software Installation Guide (English)</i>	5966-5171	—	—
<i>HP LaserJet Printer Family Paper Specification Guide</i>	5021-8956	—	—
HP LocalTalk cable kit	92215N	—	—
<i>HP Peripherals Connectivity Solutions Guide</i>	5091-6456	—	—
IEEE-1284 compliant parallel cable of 3 m (approximately 10 ft) with 25-pin male/micro 36-pin male "C" size connector	C2946A	—	—
Input paper guide (nosepiece)	C3764-60561	246	39
Label, "CAUTION"	RS5-8380-000CN	217	4A



**Table 82. Alphabetical parts list (continued)**

<b>Description</b>	<b>Part number</b>	<b>Figure</b>	<b>Ref.</b>
Laser/scanner unit	RG5-3936-000CN	222	18
Latch, roller action	RB1-5153-000CN	214	3E
	RF0-0003-000CN	217	6
Lever assembly, black cartridge	RG5-3087-000CN	219	10
Lever assembly, pressure	RG5-3045-000CN	219	7
Lever assembly, transfer drum	RG5-3046-000CN	219	6
Lever, holding, left	RB1-9705-000CN	239	9
Lever, holding, right	RB1-9704-000CN	239	8
Lever, left upper door	RB1-6485-000CN	214	4B
Lever, paper height	RA0-0112-000CN	236	12
Lever, paper sensing	RB1-6692-000CN	236	11
Lever, registration roller	RB1-9580-000CN	221	13
Lever, release	RB1-9748-000CN	239	25
Lever, right lower cover	RB1-6485-000CN	216	16D
Lever, right upper door	RB1-6485-000CN	216	17
Lever, shutter	RA0-0008-000CN	214	3B
Locating pin, metal (positioning)	RF5-2556-000CN	242	78
Macintosh DIN-8 printer cable	92215S	—	—
Magenta toner cartridge	C4151A	—	—
Main drive assembly	RG5-3066-000CN	221	18
Media jam knob	RB1-9928-000CN	217	7
Metallic retaining spring (spring leaf)	RB1-7835-000CN	243	93
Metallic retaining tab (plate stop)	RB1-7677-000CN	243	94
Metallic tape and housing assembly	C4785-60507	245	34
Motor, carousel (M1)	RH7-1325-000CN	220	26
Motor, cartridge (M3)	RH7-1328-000CN	224	23
Motor, main (M4)	RH7-1323-000CN	221	21
Motor, pick-up (M5)	RH7-1350-000CN	228	87
Mount, clutch	RB1-9828-000CN	220	15

**Table 82. Alphabetical parts list (continued)**

Description	Part number	Figure	Ref.
Multi-bin mailbox assembly (product number C4785A) <b>NOTE:</b> You must have a 2,000-sheet input unit in order to install a multi-bin mailbox.	C4785-60500	244	28
Multi-bin mailbox controller (with metal box)	C4785-60508	244	29
Multi-bin mailbox, repackaging kit	C4785-60513	—	—
Multi-bin mailbox, shipping lock kit	C4787-60503	—	—
Multi-bin mailbox, short C-link cable adapter	C4785-70001	—	—
Outriggers	RG5-4205-000CN	243	95
Paper deck drive assembly	RG5-3851-000CN	242	80
Paper deck drive bushing	RS5-1399-000CN	242	81
Paper deck PCA	RG5-3908-000CN	243	96
Paper pick-up assembly	RG5-3132-000CN	228	—
	RG5-3843-000CN	242	82
Paper quantity sensor PCA assembly	RG5-2166-000CN	243	97
Paper size sensor PCA assembly	RG5-2168-000CN	243	98
PCA, 10/100Base-T	J3113-61003	—	—
PCA, carousel motor (M1)	RG5-3084-000CN	241	4
PCA, cartridge release lever	RG5-3961-000CN	218	21
PCA, cassette-size sensing	RG5-1845-000CN	241	1
PCA, controller board	RG5-3037-000CN	241	3
PCA, fusing delivery sensor	RG5-3992-000CN	218	8
PCA, high-voltage converter 1	RG5-3026-000CN	220	20
PCA, high-voltage converter 2	RG5-3943-000CN	220	21
PCA, main relay	RG5-3036-000CN	241	2
PCA, paper pick-up	RG5-1860-000CN	228	103
PCA, photo-interrupter, IC, TLP1240	WG8-5210-000CN	231	4
PCA, photosensor	RG5-3079-000CN	231	8
	RG5-3080-000CN	218	2
	RG5-3032-000CN	231	7
PCA, subrelay	RG5-3085-000CN	241	5
PCA, tray 1	RG5-1884-000CN	241	6

**Table 82. Alphabetical parts list (continued)**

<b>Description</b>	<b>Part number</b>	<b>Figure</b>	<b>Ref.</b>
PCL/PJL Technical Reference Package	5021-0337	—	—
Photo-interrupter, IC, TLP1230	WG8-0291-000CN	228	52
Photo-interrupter, IC, TLP1240	WG8-5210-000CN	219, 234	23, 40
Photo-interrupter, IC, TLP1241	WG8-5362-000CN	221	24
Plastic parts 1A Anti-curl string 1B Spring for anti-curl string 1C Pulley, small bottom 1D Cable holder round gasket 1E Flat cable holder edge 1F Flat cable holder 1G Spacer plastic	C4785-60519	245	Kit 1
Plate paper limit back	RG5-4201-000CN	242	84
Plate paper limit middle	RG5-3849-000CN	242	85
Plate paper reference front	RF5-3850-000CN	242	86
Plate, duct mount	RF5-2036-000CN	218	3
Plate, end	RF5-1484-000CN	226, 227	26
Power box	C4781-60500	—	—
Power supply	C4785-60501	246	40
Power supply assembly (110V)	RH3-2185-000CN	218	25
Power supply assembly (220V)	RH3-2187-000CN	218	25
Power supply cable	RG5-3909-000CN	243	99
Power supply fuse 250V/3.15A	VD7-1893-151CN	243	100
Preconditioning exposure LED assembly	RG5-3980-000CN	216	36
Rail, PCA	RB2-0005-000CN	222	7D
Rail, tray 3	RF5-1396-000CN	223	32
Registration frame assembly	RG5-3007-000CN	231	—
Registration roller assembly	RG5-3009-000CN	232	—
Ring, E	XD2-1100-502CN	220	501
	XD2-1100-642CN	219	501
Rod, power switch	RB1-6463-000CN	220	5
Roller, feed	RF5-1834-000CN	228	20
Roller, paper	RB1-6488-000CN	216	16G

**Table 82. Alphabetical parts list (continued)**

<b>Description</b>	<b>Part number</b>	<b>Figure</b>	<b>Ref.</b>
Roller, pick-up	RF5-1835-000CN	228, 242	21, 83
Roller, tray 1 pick-up	RB1-9526-000CN	234	10
Screw kit (2,000-sheet input unit)	RY7-5044-000CN	242, 243	Kit 1
Screw, RS, M3 x 6	XA9-0849-000CN	221	26
Screw, tapping, pan head, M4 x 10	XB4-7401-007CN	228	501
Screw, TP, M3 x 6, quantity 10	XA9-0836-000CN	—	—
Screw, TP, M4 x 8, quantity 10	XA9-0926-000CN	—	—
Screw, w/washer, M3 x 8, quantity 10	XA9-0951-000CN	—	—
Screw, w/washer, M4 x 12, quantity 4	XA9-0940-000CN	222	37
Sensor assembly, color toner	RG5-3034-000CN	220	8
Sensor assembly, toner waste	RG5-3934-000CN	222	24
Sensor slider assembly	RG5-3131-000CN	223	37
Separation discharge high-voltage converter	RH3-0234-000CN	220	39
Separation discharge high-voltage converter PCA	RG5-3966-000CN	220	30
Shield case assembly	RG5-3023-000CN	222	7
Spring, compression	RB1-6486-000CN	216	16E
	RB1-9675-000CN	220	4
	RS5-2719-000CN	215	51B
Spring, leaf	RB1-6909-000CN	220	6
Spring, left upper door lever	RB1-6486-000CN	214	4C
Spring, right lower door lever	RB1-6486-000CN	216	22
Spring, tension	RS5-2465-000CN	220	28
	RS5-2561-000CN	243	101
Spring, torsion	RB1-6409-000CN	231	2
	RB1-6558-020CN	228	49
	RB1-9798-000CN	216	26
	RS5-2697-000CN	223	20
	RS5-2698-000CN	223	16
Static charge eliminator assembly	RG5-3973-000CN	223	14
Stop, flip-up media	RA0-0073-000CN	215	2D

**Table 82. Alphabetical parts list (continued)**

<b>Description</b>	<b>Part number</b>	<b>Figure</b>	<b>Ref.</b>
Stopper, open/close	RB1-6484-000CN	215, 216	6A, 16C
Strap, front door support	RB1-4497-000CN	214	3D
Support, cover	RA0-0079-000CN	215	51A
Switch, black toner cartridge (SW644)	WC4-5136-000CN	219	22
Switch, toner cartridge cover (SW672)	WC4-5150-000CN	218	30
Token Ring	J3112A	—	—
Transfer belt assembly	RG5-3047-000CN	238	—
Transfer drum	RG5-3039-000CN	222	17
Transfer drum cleaner holder assembly	RG5-3111-000CN	223	21
Transfer drum contact assembly	RG5-3044-000CN	220	2
Transfer kit Transfer drum Transfer belt Cleaning roller Charcoal filter Hand wipe	C4154A	—	—
Transfer mount assembly	RG5-3008-000CN	223	36
Transfer swing assembly	RG5-3010-000CN	221	10
Transport belt motor (with fan)	C4785-60518	246	41
Tray 1 assembly	RG5-3134-000CN	235	—
Tray 1 pick-up assembly	RG5-3054-000CN	234	—
Tray 4	RG5-3845-000CN	242	79
Tray rail assembly	RG5-1851-000CN	221	3
Tray, face-up	RB1-6491-000CN	214	11
Universal power supply assembly	RG5-4021-000CN	243	102
User LED PCA (with cable)	C4785-60515	244	20
Vertical transfer unit (VTU)	RG5-3854-000CN	242	89
Waste toner tray	RB1-9804-000CN	217	5
Yellow toner cartridge	C4152A	—	—



# Index

## Symbols

- Value + key 66

## Numbers

100Base-TX networks 62, 446  
10Base2 networks 63  
10Base-T networks 62, 446  
11-by-17-inch sized media. *See* media  
12-by-18.5-inch sized media. *See* media  
2,000-sheet input unit  
  back cover 273  
  cable connections 61  
  communication error 330  
  components 271  
  controller board 182  
  controller PCA 279  
  covers and doors 492  
  description 180  
  DIP switches 430  
  error 330, 331  
  front cover 272  
  front LED PCA assembly 280  
  LEDs 182, 427, 429  
  left cover 274  
  location 38  
  main drive assembly 282  
  motor test 431  
  normal/diagnostic mode switch 182  
  paper path 185  
  paper pick-up assembly 278  
  paper size sensor assemblies 283  
  paper size switch assembly 284  
  pick-up and feed system 182  
  power supply 180, 182, 281, 428  
  printer model included with 19  
  quantity switch assembly 283  
  rear view 428  
  right cover 276  
  sensor test 432  
  sensors, switches, clutches, and motors 181  
  standalone diagnostics 431  
  standalone running test 430  
  tension springs 285  
  troubleshooting 426

## A

A3-sized media  
  paper size detection switches 176  
  paper size detection switches (2,000-sheet input unit) 183  
  *See also* media  
A4-sized media  
  overriding with letter 74  
  paper size detection switches 176  
  paper size detection switches (2,000-sheet input unit) 183  
  setting for wide 77  
  *See also* media  
A5-sized media  
  paper size detection switches 176  
  *See also* media  
absorption of color 126  
access denied 334  
accessories  
  available 19  
  information from HP FIRST 52  
  ordering 49, 53, 445  
  paper handling 38  
  parts list 446  
acoustic emission specifications 22  
additive color process 126  
adjusting  
  color balance 414  
  colors 415  
  neutral axis 418  
Adobe PostScript. *See* PostScript (PS)  
air filter door 36  
air filters. *See* filters  
alphabetical parts list 513  
altitude specifications 21  
anti-curl strings (multi-bin mailbox) 301  
Append CR to LF command 77  
application notes  
  HP Driver Distribution Center 53  
  HP FIRST 52  
ASAP (Automated Support Access Program) 52  
ASIC test 82  
assemblies  
  black cartridge cam 450  
  black cartridge guide 450  
  delivery 450  
  delivery cover 486  
  delivery drive 259, 450

- (assemblies, continued)
  - delivery frame 451
  - drum/cartridge drive 267, 451, 472
  - face-down output 225
  - face-up exit 236
  - feeder 233, 482
  - formatter 37
  - front 227
  - fuser 451, 488
  - high-voltage converter 1 262
  - high-voltage converter 2 264
  - illustration of major 450
  - left 229
  - left cover feeder 450
  - main gear 261
  - paper pick-up 243, 450
  - PCA 491
  - rear 246
  - registration frame 450
  - registration roller 239, 450, 481
  - right 237
  - separation discharge converter 268
  - solenoid 451
  - top 223
  - transfer belt 450, 487
  - tray 1 450, 484
  - tray 1 pick-up 244, 450, 483
  - tray 2 475
  - tray 3 474
- assemblies (2,000-sheet input unit)
  - front LED PCA 280
  - main drive 282
  - paper pick-up 278
  - paper size sensor 283
  - paper size switch 284
  - quantity switch 283
- assemblies (multi-bin mailbox)
  - attachment 309
  - delivery head 192, 303
  - flipper 192, 291
  - metallic tape and housing 297
- assistance. *See* support
- atmospheric pressure 23
- attachment assembly (multi-bin mailbox) 309
- Attention Indicator light 66
- Automated Support Access Program (ASAP) 52
- automatic paper override 74
- axis, adjusting neutral 418

**B**

- B4-sized media
  - paper size detection switches 176
  - paper size detection switches (2,000-sheet input unit) 183
- B5-sized media
  - paper size detection switches 176
  - See also* media
- back cover
  - 2,000-sheet input unit 273
  - multi-bin mailbox 286, 287
- background toner scatter 407
- banding
  - 14 mm 411
  - black, brown, or orange 407
  - less than 10 mm 411
- belts
  - jams 437
  - replace frequency 105
  - transport 192
  - See also* transfer belt
- bidirectional mode (multi-bin mailbox) 187
- binding 73
- bins. *See* left (face-up) output bin; output bins; top (face-down) output bin
- black
  - detail value 79
  - smooth value 79
  - streaks 408
  - stripes 407
- black and white print speeds 20
- black toner cartridge
  - cam assembly 450
  - guide assembly 450
  - illustration 124
  - installing 87
  - location 104
  - replace frequency 105
  - switch 175
  - toner level detection 147
- blank page 400
- blind cover (multi-bin mailbox) 192
- BNC
  - accessories 446
  - connection 62
  - port 62
  - T connector 63
- boards. *See* PCAs; PCAs (2,000-sheet input unit); PCAs (multibin mailbox)
- bond media. *See* media
- brown stripes 407



- buffer
  - EIO overflow 316
  - parallel I/O overflow 317
  - scan error 330
- bumps on printed page 410
- buttons. *See* keys on control panel

**C**

- C5-sized media. *See* media
- cables
  - C-link 61, 188
  - coaxial 63
  - connection 60
  - interface 61
  - parallel 64
  - parts list 447
  - ThinLAN 63
- calibration
  - color density 148
  - flipper 437
  - message 334
- Canadian Customer Care Center (CCCC)
  - Assist Line 54
- Canadian DOC regulations 39
- Cancel Job key 66
- canceling
  - job 334
  - proof and print jobs 72
- capacity
  - circuit 21
  - input trays 28
  - media in multi-bin mailbox 30
  - media in printer 28
- card stock. *See* media
- carousel
  - color toner error 323
  - control process 150
  - position sensor 150
  - stop solenoid 151
- carousel button switch 175
- carousel motor
  - description and illustration 160
  - location 159
  - PCA 256
  - removing 257
- carousel position sensor 173
- carousel stopper solenoid 177
- carriage return command 77
- cartridge motor
  - description and illustration 162
  - location 159
  - removing 254
- cartridges
  - disengaged toner 323
  - imaging drum 124
  - installing black toner 87
  - (cartridges, continued)
    - installing color toner 88
    - location 104
    - replace frequency 105
    - toner not installed 345
- CASSETTE mode 90
- CCC (Customer Care Center) Assist Line 54
- CCCC (Canadian Customer Care Center) Assist Line 54
- charcoal filter
  - installing 106
  - location 104
  - replace frequency 105
- charging roller
  - illustration 124
  - repetitive defects 421
- charts, timing. *See* timing charts
- checklists
  - paper path 378
  - pretroubleshooting 315
- circles on page 403
- circuits
  - capacity 21
  - fuser abnormality detection 154
  - fusing heater safety 154
  - high-voltage power supply 155
  - laser/scanner motor lock detection 158
  - power distribution 152
  - Power Save 153
- cleaning
  - density sensor 100, 335
  - images 138
  - imaging drum 140
  - post charger 99
  - toner from fabric 87
  - transfer charger 101
  - transfer drum 138, 422
  - waste toner tray 102
- cleaning roller
  - charging process 138
  - control process 150
  - illustration 124
  - location 104
  - press cam 138
  - press solenoid 138, 177
  - repetitive defects 421
  - replace frequency 105
- cleared job 351
- clearing
  - duplexer jams 335
  - event log 81
  - fuser jams 336
  - input tray jams 338
  - multi-bin mailbox jams 338
  - paper 341

- (clearing, continued)
  - top output bin jams 339
  - transfer drum jams 340
  - unexpected paper size jams 340
- C-link cable
  - connection 37, 61
  - description 188
- clutches
  - feed roller 177
  - names and locations 177
  - registration roller 177
  - transfer belt press 177
  - tray 1 pick-up roller 177
- clutches (2,000-sheet input unit)
  - main drive 182
  - names and locations 181
  - VTU 182
- CLx. *See* clutches; clutches (2,000-sheet input unit)
- coaxial cables 63
- cold reset (CR)
  - message 341
  - paper size 81
- Color Adjust Menu 79
- color adjust page 415
- color cartridge sensor 227
- color page count 80
- color toner carousel 124
- color toner cartridges
  - illustration 124
  - installing 88
  - lever sensor 146
  - location 104
  - replace frequency 105
  - sensor 145, 173
  - toner level detection 145
- color toner lever sensor 173
- colored media
  - using 32
  - See also* media
- colors
  - adjustment 414, 415
  - density calibration 148
  - fixing inaccurate 100
  - matching 385
  - pages printed 80
  - pigments 32, 126, 127
  - print speeds 20
  - process 127
  - registration values 81
  - selection process 385
  - theory 126
  - values 79
- Com 10-sized media. *See* media
- commands
  - carriage return 77
  - line feed 77
- Commercial #10-sized media. *See* media
- communications link. *See* C-link cable
- Configuration Menu 75
- configuration page
  - printing 71, 353
  - printing continuous 71
  - understanding 361
  - using to verify installation 92
- configuring
  - Append CR to LF 77
  - binding 73
  - clearable warnings 75
  - color values 79
  - control panel 68
  - default orientation 76
  - default paper size 76
  - duplex printing 73
  - form length 76
  - I/O timeout 78
  - input trays 72, 90
  - low and out messages 75
  - manual feed 74
  - media sizes 91
  - media types 90, 91
  - number of copies 76
  - paper destination 73
  - parallel advanced functions 78
  - PCL font information 76
  - PCL symbol sets 77
  - Power Save mode 75
  - printer personalities 75
  - wide A4 77
- conformity, declarations of 40
- connecting
  - cables 60
  - printer to network 62
- consumables
  - installing 85
  - location 104
  - low and out messages 75
  - ordering 51, 445
  - parts list 446
  - recycling 105
  - replace frequency 105
  - storage specifications 23
  - user-replaceable 205
- contents of box 59
- continuous configuration pages, printing 71
- continuous test message 341

- control panel
  - display language 84
  - illustration and description 66
  - LEDs 66
  - location 35
  - menu maps 68
  - messages 316
  - removing 223
- control panel overlay
  - changing 65
  - parts list 448
- controller
  - electronic error 332
  - RAM error 330
- controller boards
  - 2,000-sheet input unit 182, 279
  - EPH (external paper-handling) 180, 188
  - multi-bin mailbox 190, 192, 299
  - printer 253
- copies, configuring 76
- corona wire. *See* transfer charger
- counts
  - total color pages printed 80
  - total pages duplexed 81
  - total pages printed 80
- Courier default settings 77
- covers
  - front 208
  - front right 209
  - left lower 216
  - left rear 213
  - left upper 215
  - location 206
  - parts list 452, 457
  - rear 222
  - right lower assembly 221
  - right rear 220
  - right upper assembly 217
  - right upper subassembly 219
  - top 211
- covers (2,000-sheet input unit)
  - back 273
  - front 272
  - left 274
  - parts list 492
  - right 276
- covers (multi-bin mailbox)
  - blind 192, 290
  - front and back 286, 287
  - top 288
- CR (cold reset)
  - message 341
  - paper size 81
- CRC test 82
- curl, reducing on transparencies 378

- Customer Care Center (CCC) Assist Line 54
- Customer Care Online 50
- Customer Information Centers 53
- Customer Support Sales Center 53
- cyan
  - detail value 79
  - smooth value 79
- cyan toner cartridge
  - installing 88
  - location 104
  - replace frequency 105

## D

- damaged
  - media 341
  - transfer drum 335
- dark transparencies 412
- Data Indicator light 66
- data, corrupt PjL 351
- Dealer Response Line 53
- dealer, finding 445
- declarations of conformity 40
- defaults
  - Courier setting 77
  - factory 355
  - fonts 76
  - number of copies 76
  - orientation 76
  - paper size 76
  - PCL symbol set 77
  - resetting factory 78
- defects
  - input tray switches 378
  - repetitive 419
  - repetitive ruler 420
  - sensors 379
- deleted fonts 351, 355
- delivery assembly 450, 485
- delivery cover
  - assembly 486
  - switch 175
- delivery drive assembly
  - location 450
  - parts list 473
  - removing 259
- delivery frame assembly 451
- delivery head (multi-bin mailbox)
  - assembly 192, 303
  - assembly jams 438
  - line 192
  - motor 190, 192
  - position motor 293
  - position system jams 438
  - roller motor 190

- delivery rollers 124
  - extended sensor (multi-bin mailbox) 190
- demonstration page, printing 353
- denied access 334
- density sensor
  - cleaning 100, 335
  - description 148
  - error 324
  - removing 242
- depth of printer 22
- detail color value 79
- developer DSD wheels, repetitive defects 421
- developer motor test 83
- developer roller repetitive defects 421
- diagnostic LED (multi-bin mailbox) 307
- diagnostic LEDs (2,000-sheet input unit) 182
- diagnostics
  - 2,000-sheet input unit 431
  - formatter board 81
  - multi-bin mailbox 434
  - switch 182
- diagrams, circuit 440
- DIMMs (dual inline memory modules)
  - accessories 19
  - errors 322
  - expanding memory 19
  - installing 93
  - ordering 445
  - parts list 446
  - removing 356
  - slot locations 37
  - test 82
- DIN-8 connection 62
- DIP switches (2,000-sheet input unit) 428, 430
- directories, printing file 71
- disk. *See* hard disk
- dithering 127
- diverter for paper out of position 328
- DL-sized media. *See* media
- DOC regulations, Canadian 39
- documentation
  - ordering 50
  - parts list 448
- doors
  - location 206
  - parts lists 452, 457, 492
  - vertical transfer unit open 345
- dots per inch (DPI) printer resolution 20
- Double Post Card (JPOSTD) sized media. *See* media
- double-sided printing. *See* duplexer; duplex printing
- DPI (dots per inch) printer resolution 20
- DRAM (dynamic random access memory)
  - installing 93
  - test 82
- Driver Distribution Center 53
- drivers. *See* printer drivers
- drum
  - imaging error 342
  - imaging life out 343
  - imaging not installed 347
  - imaging problems 424
  - new transfer 352
  - transfer damaged 335
  - transfer jams 340
  - transfer not installed 348
  - transfer problems 422
- drum kit
  - low and out messages 75
  - parts list 447
  - replace frequency 105
- drum motor 159
  - description and illustration 161
  - test 83
- Drum MSDS 45
- drum/cartridge drive assembly
  - illustration 451
  - illustration and parts list 472
  - removing 267
- drums
  - cleaning transfer 422
  - illustration 124
  - installing imaging 110
  - installing transfer 106
  - location 104
  - replace frequency 105
- dual inline memory modules (DIMMs). *See* DIMMs (dual inline memory modules)
- dull transparencies 412
- duplex printing
  - configuring 73
  - process 192
  - total page count 81
- duplexer
  - accessories 19, 446
  - deflector 124
  - error 343
  - jams 335, 338
  - location 38
  - media specifications 31
  - printer model included with 19
- dynamic random access memory (DRAM). *See* DRAM (dynamic random access memory)

## E

- ECCC (European Customer Care Center)
  - Assist Line 54
- EIO (enhanced input/output)
  - accessories parts list 446
  - buffer overflow 316
  - connection broken 317
  - features 20
  - initializing 343
  - not functional 344
  - printing page 71
  - slot locations 37
- EIO hard disk
  - parts list 446
- eject rollers (multi-bin mailbox) 192
- ejector motor (multi-bin mailbox) 190
- electrical
  - schematics 440
  - specifications 21
  - systems 152
- electrostatic discharge (ESD) 203
- electrostatic latent image 131, 132
- embossed media 33
- EMI statement, Korea 43
- emissions
  - acoustic 22
  - ozone 46
- empty tray 359
- engine
  - settings 81
  - test 344
- enhanced input/output (EIO). *See* EIO (enhanced input/output)
- envelopes
  - cautions for printing 31
  - sealed 379
  - See also* media
- environmental
  - automatic change control 147
  - operating requirements 24
  - specifications 21
- EP process. *See* image formation
- EPH (external paper-handling) controller
  - board 180, 188
- error log 426
- errors
  - 2,000-sheet input unit 330, 331
  - breaks and pauses 82
  - carousel 323
  - controller 332
  - cycle power 328
  - density sensor 324
  - DIMM 322
  - firmware 318
  - flipper 437
  - fuser 319

- (errors, continued)
  - illegal output 325
  - input feed 325
  - internal 329
  - laser 320
  - laser scanner 317
  - messages 316
  - motor 329
  - multi-bin mailbox 330, 332
  - NVRAM 333, 438
  - PostScript printing 75
  - power-on self-test 333
  - RAM 329, 330
  - scan buffer 330
- ESD (electrostatic discharge) 203
- Ethernet
  - accessories 446
  - network connection 62
- European Customer Care Center (ECCC)
  - Assist Line 54
- event log 353
  - clearing 81
  - description 364
  - printing 71
- exchanging parts 51
- Executive-sized media. *See* media
- expanding memory 19
- expired
  - fuser and paper rollers 344
  - imaging drum 343
- external paper-handling (EPH) controller
  - board 180, 188

## F

- face-down bins (multi-bin mailbox) 192
- face-down output assembly 225
- face-down output bin. *See* top (face-down) output bin
- face-down tray delivery sensor 166
- face-up bin (multi-bin mailbox) 192
- face-up exit assembly 236
- face-up output bin. *See* left (face-up) output bin
- face-up solenoid 234
- factory defaults reset 78
- factory settings, restoring 355
- failed hard disk 342
- faint print 409
- fan 1
  - motor location 159
  - operation 165
  - removing 250
- fan 2
  - motor location 159
  - operation 165
  - removing 251

- fan 3
  - motor location 159
  - operation 165
- fans
  - left output failure 328
  - rear input failure 327
  - rear output failure 326
  - thermistor 165
- fault log 82
- Fax Information Retrieval Support Technology (HP FIRST)
  - Europe 52
  - U.S. 52
- FCC regulations 39
- features
  - control panel 66
  - EIO 20
  - fonts 20
  - model differences 19
  - personality 20
  - print speeds 20
  - resolution 20
  - user interface 20
- feed roller clutch 177
- feed rollers
  - 2,000-sheet input unit 182, 185
  - printer 124
- feeder assembly 233, 482
- feeding
  - error 325
  - manual 350
  - process 167
  - speeds 167
- field replaceable units (FRUs)
  - 2,000-sheet input unit 271
  - ordering 51
  - parts list 449
- files
  - operation failed 342
  - printing directories 71
- filters
  - installing air 110
  - installing charcoal 106
  - location 104
  - ozone 46
  - replace frequency 105
- Finland laser statement 44
- firmware
  - error 318
  - test 82
- FIRST (Fax Information Retrieval Support Technology)
  - Europe 52
  - U.S. 52
- FIRST mode 90
- fixer. *See* fuser
- fixing. *See* fusing
- flipper
  - assembly 192, 291
  - calibration 437
  - error 437
  - jam 437
  - roller motor 190
- flip-up media stop 35
- FMx. *See* fan 1; fan 2; fan 3; fans
- fonts
  - configuring PCL number 76
  - configuring PCL pitch 76
  - configuring PCL point size 76
  - configuring PCL source 76
  - Courier settings 77
  - deleted 351
  - deleted downloaded 355
  - Postscript (PS) 20
  - printing list 354
  - standard 20
  - support 52
  - TrueType 20
- form length, configuring 76
- formatter assemblies 37
- formatter board 230
  - diagnostics 81
  - location 36, 37
  - parts list 449
  - serial number 80
  - video test (VX ASIC) 82
- formatter pan 248
- frequency for replacing consumables 105
- front assemblies 227
- front cover
  - 2,000-sheet input unit 272
  - multi-bin mailbox 286, 287
  - removing 208
  - switch 175
- front door 35
- front LED PCA assembly (2,000-sheet input unit) 280
- front right cover 209
- FRUs (field replaceable units). *See* field replaceable units (FRUs)
- full
  - hard disk 342
  - left (face-up) output bin 437
- fuser
  - abnormality detection circuit 154
  - assembly 451, 488
  - control process 154
  - error 319
  - incompatible 345
  - installing 113
  - jams 336
  - life low 344

- (fuser, continued)
  - location 104
  - new 352
  - not installed 346
  - repetitive defects 424
  - temperatures 154
- fuser kit
  - installing 113
  - life detection 144
  - low and out messages 75
  - parts list 447
  - percentage life remaining 81
  - replace frequency 105
  - resetting life count 78
- fusing
  - and delivery process 179
  - delivery sensor 166, 173, 178, 179
  - heater safety circuit 154
  - process 141
  - rollers 124, 141

**G**

- ghosting 406
- glossy
  - print speeds 20
  - using 32
  - See also* media
- Go key 66
- graphics resolution 20
- guide, input paper. *See* input paper guide (multi-bin mailbox)

**H**

- half-toning 127
- handling
  - media 26
  - toner 45
- hard disk
  - accessories 19
  - failure 342
  - full 342
  - initializing 75, 353
  - location 37
  - new 352
  - parts list 446
  - removing 232, 356
  - test 82
  - write-protected 342
- HCI. *See* 2,000-sheet input unit
- HCO. *See* multi-bin mailbox
- heaters
  - fusing safety 154
  - lower and upper fuser 159
  - names and locations 159

- heavy media
  - using 32
  - See also* media
- height of printer 22
- Hewlett-Packard Distribution (HPD)
  - ordering information 49
- high capacity output. *See* multi-bin mailbox
- high-voltage converter 1
  - assemblies 262
  - removing 263
  - removing PCA 262
- high-voltage converter 2
  - assemblies 264
  - removing 265
  - removing PCA 264
- high-voltage converter 3. *See* separation discharge high-voltage converter
- high-voltage power supply circuit 155
- horizontal
  - lines (all colors) 402
  - lines (one color) 401
  - lines (yellow or black) 408
- HP ASAP (Automated Support Access Program) 52
- HP Automated Support Access Program (ASAP) 52
- HP Customer Care Online 50
- HP dealer, finding 445
- HP Direct 53
- HP Distribution ordering information 49
- HP Driver Distribution Center 53
- HP Fax Information Retrieval Support Technology (FIRST)
  - Europe 52
  - U.S. 52
- HP FIRST (Fax Information Retrieval Support Technology)
  - Europe 52
  - U.S. 52
- HP JetDirect internal print server. *See* print server
- HP LaserJet printing demonstration 71
- HP Technical Training 50
- HPD (Hewlett-Packard Distribution)
  - ordering information 49
- humidity
  - automatic environment change control 147
  - sensor 147
  - sensor error 323
  - specifications 21, 23

- I
- I/O (input/output)
  - parallel advanced functions 78
  - resetting 78
  - resetting ports 355
  - switching 20
  - timeout 78
- I/O Menu 78
- identification of printer 34
- illegal output error 325
- image formation
  - cleaning 138
  - cleaning roller charging 138
  - fusing 141
  - imaging drum cleaning 140
  - laser beam exposure 132
  - post charging 135
  - preconditioning exposure 131
  - primary charging 132
  - process 129
  - secondary transfer 136
  - troubleshooting 383
- images
  - early or late on page 399
  - printed repeatedly 406
  - resolution 20
  - skewed 399
  - troubleshooting defects 386
- imaging drum
  - cartridge 124
  - cleaning process 140
  - detecting expiration 142
  - error 342
  - illustration 124
  - installing 110
  - kit 110
  - laser beam exposure 132
  - life out 343
  - location 104
  - not installed 347
  - preconditioning exposure 131
  - primary charging 132
  - repetitive defects 424
  - replace frequency 105
  - switch 175
- Information Menu 71
- initializing
  - EIO accessory 343
  - hard disk 353
  - printer hard disk 75
- input feed error 325
- input paper guide (multi-bin mailbox) 192, 295
- input trays. *See* 2,000-sheet input unit; tray 1; tray 2; tray 3; tray 4; trays
- input/output (I/O). *See* I/O (input/output)
- inside left panel 210
- installing
  - air filters 110
  - black toner cartridge 87
  - cables 60, 61
  - charcoal filter 106
  - consumables 85, 105
  - DIMMs 93
  - fuser kit 113
  - imaging drum 86
  - imaging drum kit 110
  - parts 199
  - printer on network 62
  - rollers 113
  - safety 203
  - transfer belt 106
  - transfer charger 106
  - transfer drum 106
  - transfer kit 106
  - verifying printer 92
- insufficient memory 316
- interface
  - cable 61
  - features 20
- interlock switch (multi-bin mailbox) 190, 306
- internal components 460
- internal print server. *See* print server
- ISO B5-sized media. *See* media
- ITD (intermediate transfer drum). *See* transfer drum
- Item key 66
- J
- jams
  - delivery head assembly 438
  - delivery head position system 438
  - detection process 180
  - duplexer 335
  - flipper area 437
  - fuser 336
  - general media 340
  - input tray 338
  - multi-bin mailbox 338
  - selecting media to prevent 26
  - top output bin 339
  - transfer belt 437
  - transfer drum 340
  - tray 4 340
  - troubleshooting 379
  - unexpected paper size 340
- Japan VCCI statement 43
- JetDirect internal print server. *See* print server
- JIS B4-sized media. *See* media
- JIS B5-sized media. *See* media



- job separator mode (multi-bin mailbox) 186
- jobs
  - canceling 334
  - canceling proof and print 72
  - cleared because memory out 351
  - processing 354
- JPOSTD (Double Post Card) sized media. *See media*

**K**

- keys on control panel
  - description 66
  - See also individual keys*
- kits
  - drum parts list 447
  - fuser parts list 447
  - replace frequency 105
  - transfer life low 357
  - transfer life out 357
  - transfer parts list 447
- Korean EMI statement 43

**L**

- labels. *See media*
- language
  - control panel overlay 65
  - not available 353
  - selecting display 84
- laser
  - error 320
  - illustration 124
  - motor lock detection circuit 158
  - process 157
  - removing 224
  - safety statement 43
  - scanner error 317
  - statement for Finland 44
- laser beam
  - exposure on imaging drum 132
  - process 157
- LaserJet printing demonstration 71
- last page sensor
  - tray 1 170
  - tray 2 168
- LCD display 66
- ledger-sized media
  - paper size detection switches 176
  - paper size detection switches (2,000-sheet input unit) 183
  - See also media*
- LEDs
  - 2,000-sheet input unit 182, 427, 429
  - control panel 66
  - multi-bin mailbox 307, 308, 436
  - preconditioning exposure 124
  - status 94
- left (face-up) output bin
  - delivery roller 124
  - full 349, 437
  - full sensor 190
  - illustration 124
  - location 35
  - paper path test 83
  - solenoid 177, 179
- left assemblies 229
- left cover
  - feeder assembly 450
  - sensor 173
- left cover (2,000-sheet input unit) 274
- left lower cover 36, 216
- left rear cover 213
- left upper cover 36, 215
- legal-sized media
  - paper size detection switches 176
  - paper size detection switches (2,000-sheet input unit) 183
  - See also media*
- length, configuring form 76
- letterhead. *See media*
- letter-sized media
  - overriding with A4 74
  - paper size detection switches 176
  - paper size detection switches (2,000-sheet input unit) 183
  - See also media*
- lever, unlocked toner 349
- life
  - drum kit low 343
  - drum kit out 343
  - fuser and paper roller low 344
  - fuser and paper rollers out 344
  - transfer kit low 357
  - transfer kit out 357
- life detection
  - fuser kit 144
  - imaging drum 142
  - transfer kit 144
- lifting plate
  - position sensor 171, 173
  - solenoid 171, 177
- lifting plate (2,000-sheet input unit) 184, 185
- lights. *See LEDs*

- line feed command 77
- lines
  - horizontal (all colors) 402
  - horizontal (one color) 401
  - horizontal (yellow or black) 408
- list server 50
- lists
  - font 71
  - parts 443
- LocalTalk
  - accessories 446
  - networks 62
  - parts list 447
  - port 62
- lock detection for laser/scanner motor 158
- logs
  - error 426
  - event 71, 81, 353, 364
  - fault 82
- loose toner 405
- low toner 356
- lower
  - fuser heater 159
  - fusing roller 124, 141
  - VTU rollers 185

**M**

- M1. *See* carousel motor
- M2. *See* drum motor
- M3. *See* cartridge motor
- M4. *See* main motor
- M5. *See* pick-up motor
- Macintosh cable parts list 447
- magenta
  - detail value 79
  - smooth value 79
- magenta toner cartridge
  - installing 88
  - location 104
  - replace frequency 105
- mailbox mode (multi-bin mailbox) 186
- mailbox. *See* multi-bin mailbox
- main drive (2,000-sheet input unit)
  - assembly 282
  - clutch 182
- main gear assembly 261
- main motor
  - description and illustration 163
  - location 159
- main motor (2,000-sheet input unit) 182
- main relay PCA 266
- maintenance
  - black toner cartridge 87
  - color toner cartridges 88
  - consumables 85
  - imaging drum 86
  - (maintenance, continued)
    - strategy 203
    - user-replaceable parts 205
- maintenance units. *See* consumables
- manual feed 74, 350
- manuals, ordering 50
- matching colors 385
- Material Safety Data Sheet (MSDS) 45, 52
- maximum media sizes 28
- MBM. *See* multi-bin mailbox
- media
  - capacities (multi-bin mailbox) 30
  - capacities (printer) 28
  - cautions for printing 33
  - configuring default size 76
  - configuring destinations 73
  - configuring sizes 91
  - configuring types 90, 91
  - duplexer specifications 31
  - error feeding from tray 1 328
  - handling 26
  - input tray capacities 28
  - jams 340
  - overriding type/size 74
  - parts list 447
  - print speeds 20
  - requirements 26
  - selecting 26
  - specifications 26
  - storing 27
  - to avoid 33
  - trays. *See* tray 1; tray 2; tray 3; tray 4; trays
    - See also* envelopes; glossy; labels; paper; transparencies
- media size sensing PCAs 269
- memory
  - accessories 19
  - expanding 19
  - external error (NVRAM) 438
  - full 355
  - installing DIMMs 93
  - insufficient 316
  - internal error 329
  - model differences 19
  - out and job cleared 351
  - parts list 446
  - PCL full 351
  - shortage 350
- Menu key 66
- menu maps
  - description 68
  - printing 71

- menus
  - Color Adjust 79
  - Configuration 75
  - control panel 68
  - I/O 78
  - Information 71
  - Paper Handling 72
  - Printing 76
  - Proof and Print 72
  - Resets 78
  - Service Mode 80
- messages
  - cold reset 341
  - control panel 316
  - language used 84
  - low and out 75
  - multi-bin mailbox 436
  - numbered 316
  - unnumbered 334
- metallic tape and housing assembly (multi-bin mailbox) 297
- minimum media sizes 28
- misfed paper 341
- model numbers 34
- models of printer, different features 19
- modes
  - CASSETTE 90
  - FIRST 90
  - OHT 167
  - Power Save 75, 153, 351
  - service 80
  - tray 1 72, 90
- modes (multi-bin mailbox)
  - bidirectional 187
  - job separator 186
  - self-test 436
  - unidirectional 187
  - virtual stacker 186
- Monarch-sized media. *See* media
- motors
  - carousel 159, 160, 257
  - cartridge 159, 162, 254
  - developer 83
  - drum 83, 159, 161
  - error 329
  - fan 159, 165
  - laser/scanner lock detection 158
  - main 159, 163
  - names and locations 159
  - not turning 321
  - pick-up 159, 164
- motors (2,000-sheet input unit)
  - main 182
  - names and locations 181
  - test 431
- motors (multi-bin mailbox)
  - delivery head 190, 192
  - delivery head position 293
  - delivery head roller 190
  - ejector 190
  - flipper roller with encoder 190
  - names and locations 189
  - transport belt 190, 192, 294
- mottled print 408
- MSDS (Material Safety Data Sheet) 45, 52
- multi-bin mailbox
  - accessories 19, 446
  - anti-curl strings 301
  - attachment assembly 309
  - back cover 287
  - blind cover 290
  - capacities 30
  - clearing jams 338
  - communication 188
  - communication error 330
  - components 286, 496
  - controller board 190, 192
  - controller PCA 299
  - delivery head assembly 303
  - delivery head position motor 293
  - description 186
  - diagnostic LED PCA 307
  - diagnostic tests 434
  - error 332
  - flipper assembly 291
  - front cover 287
  - full 349
  - input paper guide 295
  - interlock switch 306
  - location 38
  - messages 436
  - metallic tape and housing assembly 297
  - not attached correctly 349
  - operating modes 186, 187
  - output bin full 355
  - overflow 186
  - paper bins 290
  - paper supply 289
  - power-on sequence 187
  - power-up sequence test 435
  - removable parts 286
  - removing 229
  - sensors, switches, motors, and controller board 189
  - top cover 288
  - top output bin (face-up) full 344
  - transport belt motor 294

- (multi-bin mailbox, continued)
  - troubleshooting 434
  - unlatched 437
  - user status LED PCA 308
- multipart forms 33
- multipurpose tray. *See* tray 1

## N

- networks
  - 100Base-TX 62
  - 10Base2 63
  - 10Base-T 62
  - accessories parts list 446
  - connections 62
  - printer connection 62
  - troubleshooting 439
- non-volatile random access memory (NVRAM). *See* NVRAM (non-volatile random access memory)
- number
  - formatter board serial 80
  - printer model 34
  - printer serial 80
- numerical parts lists 502
- NVRAM (non-volatile random access memory)
  - damaged 438
  - recoverable error 333
  - settings 80
  - unrecoverable error 333

## O

- OHT (overhead transparency). *See* transparencies
- OHT mode 167
- online
  - indicator 67
  - support 50
- operating
  - environment requirements 24
  - environment specifications 21
  - specifications 21
- operating system color characteristics 385
- options
  - ordering 445
  - parts list 446
- orange stripes 407
- ordering
  - accessories 445
  - consumables 51, 445
  - DIMMs 445
  - documentation and software 50
  - options 445
  - parts 445

- orientation
  - configuring default 76
  - media in input trays 28
- output bins
  - configuring destinations 73
  - full 349, 355, 357
  - jams 339
  - multi-bin mailbox 192
  - overflow 186
    - See also* left (face-up) output bin; top (face-down) output bin
  - overflow bin (multi-bin mailbox) 186
- overhead transparencies. *See* transparencies
- overriding
  - A4 with letter 74
  - letter with A4 74
  - media type/size 74
- ozone
  - filter 46
  - safety 46

## P

- package contents 59
- pages
  - blank 400
  - configuration 353
  - demonstration 353
  - image early or late 399
  - printing color test 79
  - rings (circles) on 403
  - simplified 350
  - total color printed 80
  - total count 80
  - wrinkled 378
  - wrong request 438
- panel, inside left 210
- paper
  - clearing 341
  - cold reset size 81
  - configuring default size 76
  - configuring destinations 73
  - diverter out of position 328
  - feeding speeds 167
  - handling accessories 446
  - overriding size 74
  - print speeds 20
  - roller life low 344
  - rollers life out 344
  - tray 1 pick-up 171
  - tray 2 and tray 3 pick-up 169
  - unexpected size or type 318
    - See also* media
- paper bin (multi-bin mailbox)
  - empty sensor 190
  - full sensor 190

- paper delivered to bin sensor (multi-bin mailbox) 190
- paper delivered to head sensor (multi-bin mailbox) 190
- paper entry sensor
  - 2,000-sheet input unit 182
  - multi-bin mailbox 190
- paper exit sensor (2,000-sheet input unit) 182
- paper guide. *See* input paper guide (multi-bin mailbox)
- paper handling accessories
  - location 38
  - model differences 19
- Paper Handling Menu 72
- paper jams. *See* jams
- paper path
  - 2,000-sheet input unit 185
  - carousel obstruction 323
  - checklist 378
  - door open 345
  - illustration 166
  - jams 340
  - multi-bin mailbox 191
  - tests 83, 365
  - tests (multi-bin mailbox) 435
  - troubleshooting 378
- paper photo sensors 241
- paper pick-up
  - assembly 450
  - illustration 169, 171
  - process 167, 168
- paper pick-up (2,000-sheet input unit) 182
- paper pick-up assembly
  - illustration and parts list 476
  - location 450
  - removing 243
- paper quantity switches (2,000-sheet input unit) 182, 183
- paper size detection switches
  - 2,000-sheet input unit 183
  - printer 176
- paper size sensors (2,000-sheet input unit) 182
- paper size switch assembly (2,000-sheet input unit) 284
- paper stack (2,000-sheet input unit) 185
- paper tray sensors (2,000-sheet input unit)
  - empty 182
  - raised 182
- paper trays. *See* 2,000-sheet input unit; input trays
- paper width sensor 170
- parallel advanced functions 78
- parallel cable
  - connection 64
  - parts list 447
- parallel I/O (input/output) buffer overflow 317
- parallel port 37, 64
- part numbers. *See* parts lists
- parts
  - exchanging 51
  - HP Direct 53
  - ordering 49, 445
  - phone number identification 53
  - removing and installing 199
  - user-replaceable 205
  - website information 50
- parts lists
  - alphabetical 513
  - by part 449
  - cables 447
  - consumables, options, and accessories 446
  - control panel overlays 448
  - covers and doors (2,000-sheet input unit) 492
  - covers and doors (printer) 457
  - delivery assembly 485
  - delivery cover assembly 486
  - delivery drive assembly 473
  - DIMMs 446
  - drum kit 447
  - drum/cartridge drive assembly 472
  - EIO 446
  - EIO hard disk 446
  - feeder assembly 482
  - fixing assembly 490
  - formatter board 449
  - fuser kits 447
  - internal components 461
  - internal hard disk 446
  - lower cassette assembly 474
  - media 447
  - memory 446
  - multi-bin mailbox components 497, 499, 501
  - multi-purpose tray assembly 484
  - multi-purpose tray pick-up assembly 483
  - network 446
  - numerical 502
  - paper handling accessories 446
  - paper pick-up assembly 479
  - PCA assemblies 491
  - printer supplies 447
  - reference materials 448
  - registration frame assembly 480
  - registration roller assembly 481

- (parts lists, continued)
  - toner cartridges 447
  - transfer assembly 487
  - transfer kits 447
  - upper cassette assembly 475
- PCAs
  - assemblies 491
  - carousel motor 256
  - high-voltage converter 1 262
  - high-voltage converter 2 264
  - main relay 266
  - power supply circuit 155
  - separation discharge high-voltage converter 268
  - subrelay 228
  - tray 2 and tray 3 media size sensing 269
- PCAs (2,000-sheet input unit)
  - controller 279
  - front LED 280
- PCAs (multi-bin mailbox)
  - controller 299
  - diagnostic LED 307
  - user status LED 308
- PCBs. *See* PCAs; PCAs (2,000-sheet input unit); PCAs (multibin mailbox)
- PCL (printer command language)
  - configuring 75
  - configuring font information 76
  - memory full 351
  - personality support 20
  - printing font list 71
  - symbol sets 77
- personalities
  - configuring 75
  - supported 20
- photo sensors 241
- pick-up motor
  - description and illustration 164
  - location 159
- pick-up process. *See* paper pick-up
- pick-up rollers
  - 2,000-sheet input unit 182, 185
  - printer 238
- pick-up unit
  - cover sensor 173
  - paper sensor 166, 173
- pigments 32, 126, 127
- pitch, configuring PCL font 76
- PJL operation failed 351
- plain media. *See* media
- plate registration 399
- point size for PCL font 76
- ports
  - BNC 62
  - LocalTalk 62
  - parallel 37, 64
  - resetting I/O 355
- post charger
  - cleaning 99
- post charging unit
  - illustration 124
  - process 135
- POST error 333
- PostScript (PS)
  - configuring 75
  - errors 75
  - font list 71
  - fonts 20
  - memory full 355
  - personality support 20
- power
  - button 35
  - connection 36
  - consumption 21
  - cord connection 60, 61
  - distribution circuit diagram 152
  - pack 61
  - requirements 21
  - switch 175
- Power Save mode
  - circuit 153
  - configuring 75
  - electrical specifications 21
  - fan operation 165
  - on 351
  - signal process 153
- power supply
  - circuit 155
  - removing 252
- power supply (2,000-sheet input unit)
  - description 180, 182
  - illustration 428
  - removing 281
- power supply (multi-bin mailbox) 289
- power-on self-test (POST) error 333
- power-up sequence test (multi-bin mailbox) 435
- preconditioning exposure 124, 131
- preprinted media. *See* media
- prepunched media. *See* media
- primary charging 132
- primary colors 126
- print
  - dark yellow 413
  - faint 409
  - jobs. *See* jobs
  - mottled or splotchy 408

- (print, continued)
  - smeared 404
  - speckled 403
  - speeds 20
- print server
  - accessories 19
  - connecting to network 62
  - model included with 19
  - network connection 62
- printer
  - covers and doors 452
  - dimensions 22
  - front view 35
  - messages 316
  - model and serial numbers 34
  - personality could not be run 351
  - personality does not exist 353
  - rear view 36
  - serial number 80
  - stand 35
  - supplies 447
  - verifying installation 92
  - weight 22
- printer command language (PCL). *See* PCL (printer command language)
- printer control language (PCL). *See* PCL (printer command language)
- printer control panel. *See* control panel
- printer drivers
  - color selection 385
  - handled by HP Driver Distribution Center 53
  - obtaining 50
  - request form 52
- printer hard disk. *See* hard disk
- printing
  - color test pages 79
  - configuration page 71, 353
  - continuous configuration pages 71
  - demonstration page 353
  - EIO pages 71
  - event log 71, 353
  - file directories 71
  - font list 71, 354
  - LaserJet demonstration 71
  - menu maps 71
  - PostScript errors 75
  - Printing Menu 76
  - problems. *See* errors; troubleshooting
  - process colors 127
  - processing jobs 354
  - product data sheets 52
  - programs, color selection in 385
  - proof and print jobs, canceling 72
  - Proof and Print Menu 72
  - PS. *See* PostScript (PS)
  - PSx. *See* sensors

**Q**

- quantity switch assembly (2,000-sheet input unit) 283

**R**

- radio frequency regulations 39
- raised spots on printed page 410
- RAM (random access memory)
  - controller error 330
  - internal error 329
- random access memory (RAM). *See* RAM (random access memory)
- read only memory (ROM). *See* ROM (read only memory)
- Ready Indicator light 66
- rear assemblies 246
- rear cover 222
- rear left cover 213
- recycling
  - consumables 105
  - toner cartridges 55
- reference materials parts list 448
- refilling toner cartridges 55
- registration
  - area jams 338
  - color values 81
  - incorrect 399
  - plate 399
- registration frame assembly
  - illustration and parts list 480
  - location 450
- registration roller
  - assembly 239, 450, 481
  - clutch 177
  - location 124
  - paper sensor 166, 167, 171, 173
  - removing 239
- regulations
  - Canadian DOC 39
  - FCC 39
- removing
  - parts 199
  - safety 203
  - strategy 203
  - See also individual parts*
- repair locations, Customer Support Sales Center 53
- repetitive
  - defect ruler 420
  - defects 419
  - images printing 406
- replacement frequencies 105

- replacing. *See* installing; removing
- requirements
  - media 26
  - power 21
  - site 24
  - space around printer 25
  - ventilation 24
- reset
  - cold 81, 341, 376
  - switch 175
- Resets Menu 78
- resetting
  - factory defaults 78
  - fuser life count 78
  - I/O 78
  - I/O ports 355
  - transfer life count 78
- residual toner 136, 138, 140
- resolution 20
- resource save
  - area full 351
  - data full 355
- restoring factory settings 355
- reverse stepper motor sensor (multi-bin mailbox) 190
- right assemblies 237
- right cover
  - subassembly 219
  - switch 175
- right cover (2,000-sheet input unit) 276
- right front cover 209
- right lower cover 35
- right lower cover assembly 221
- right rear cover 220
- right upper cover 35
- right upper cover assembly 217
- rings on page 403
- RJ-45 connection 62
- roller, cleaning
  - charging process 138
  - control process 150
- rollers
  - illustration 124
  - installing 113
  - location 104
  - lower fusing 141
  - paper and fuser life low 344
  - paper and fuser life out 344
  - pick-up 238
  - registration 239
  - repetitive defects 421, 422
  - replace frequency 105
  - upper fusing 141
  - waste toner feed 140

- rollers (2,000-sheet input unit)
  - feed 182, 185
  - lower and upper VTU 185
  - pick-up 182, 185
  - separation 182, 185
- rollers (multi-bin mailbox)
  - eject 192
- ROM (read only memory)
  - firmware test 82
  - installing 93
- ruler, repetitive defect 420

## S

- safety
  - laser statement 43
  - ozone 46
  - removal and replacement 203
  - toner 45
- scan buffer error 330
- scanner
  - illustration 124
  - motor lock detection circuit 158
  - motor not turning 321
  - process 157
  - removing 224
- sealed envelopes 379
- Select key 66
- selecting
  - binding 73
  - color 385
  - display language 84
  - media 26
- self-test mode 436
- sensors
  - carousel position 150, 173
  - cleaning density 335
  - color cartridge 145, 227
  - color toner cartridge 173
  - color toner level 145
  - color toner lever 146, 173
  - defective or stuck 379
  - density 148, 242
  - density error 324
  - face-down tray delivery 166
  - fusing delivery 166, 173, 178, 179
  - last page (tray 1) 170, 171, 173
  - last page (tray 2) 168, 173
  - left cover 173
  - level sensors (tray 3) 173
  - lifting plate position 171, 173
  - names and locations 172
  - not detecting toner cartridge 345
  - OHT (overhead transparency) 167, 171, 173
  - paper (tray 1) 173
  - paper level (tray 2) 173



- (sensors, continued)
  - paper out (tray 2) 173
  - paper out (tray 3) 173
  - photo paper 241
  - pick-up unit cover 173
  - pick-up unit paper 166, 173
  - registration roller paper 166, 167, 171, 173
  - reverse stepper motor (multi-bin mailbox) 190
  - separation 173
  - temperature error 323
  - temperature/humidity 147
  - test 83
  - thermistor 173
  - thermo switch 173
  - toner lock 227
  - top (face-down) output bin delivery 173, 178, 179
  - top (face-down) output bin paper full 173, 179
  - tray 1 paper 171
  - tray 1 paper width 170
  - tray 2 173
  - tray 3 173
- sensors (2,000-sheet input unit)
  - names and locations 181
  - paper entry 182
  - paper exit 182
  - paper size 182
  - paper tray empty 182
  - paper tray raised 182
  - test 432
  - vertical transfer unit (VTU) closed 182
- sensors (multi-bin mailbox)
  - delivery rollers extended 190
  - left (face-up) output bin full 190
  - names and locations 189
  - paper bin empty 190
  - paper bin full 190
  - paper delivered to bin 190
  - paper delivered to head 190
  - paper entry 190
- separation discharge high-voltage converter
  - assemblies 268
  - PCA 268
  - removing 269
- separation pad 124
- separation rollers
  - 2,000-sheet input unit 182, 185
  - printer 124
- separation sensor 173
- serial number
  - formatter board 80
  - printer 34, 80
- server, list 50
- service agreements 53
- service LEDs (2,000-sheet input unit) 428
- Service Materials Organization (SMO)
  - ordering information 49
- Service Mode Menu 80
- service notes
  - HP FIRST 52
  - ordering 50
- service tool requirements 204
- setting
  - color registration values 81
  - color values 79
- settings
  - factory 355
  - NVRAM 80
- shutter loose 323
- simplified page 350
- site requirements 24
- sizes
  - cold reset paper 81
  - configuring default paper 76
  - configuring media 91
  - configuring PCL font point 76
  - configuring tray 1 73
  - media in duplexer 31
  - media in input trays 28
  - overriding media 74
  - printer 22
- skewed images 399
- sliders problem 437
- SLx. *See* solenoids
- SME (Support Materials Europe), ordering from 49
- smear print 404
- SMO (Service Materials Organization), ordering from 49
- smooth color value 79
- software
  - matrix 52
  - ordering 50
  - support from HP FIRST 52
- solenoids
  - assembly 451
  - carousel stop 151
  - carousel stopper 177
  - cleaning roller 150
  - cleaning roller press 177
  - face-up 234
  - left (face-up) output bin 177, 179
  - lifting plate 171, 177
  - names and locations 177
  - tray 1 and tray 2 pick-up 177
  - tray pick-up 169
- space requirements 25

- specifications
  - acoustic emissions 22
  - altitude 21
  - atmospheric pressure 23
  - consumable storage 23
  - electrical 21
  - humidity 21
  - image skew 399
  - media 26
  - media storage 27
  - operating environment 21
  - printer dimensions 22
  - temperature 21, 23
- speckled print 403
- speeds
  - factors affecting 20
  - paper feed 167
  - print 20
- splotchy print 408
- spots
  - background toner scatter 407
- springs, tension (2,000-sheet input unit) 285
- stacker output bin full 355
- statements
  - Finland laser 44
  - Korean EMI 43
  - laser safety 43
  - VCCI (Japan) 43
  - warranty 55
- status LEDs. *See* LEDs
- status lights. *See* LEDs
- storage
  - consumable specifications 23
  - media 27
  - printer specifications 21
  - too many devices 356
- stray toner 410
- streaks (yellow or black) 408
- stripes (black, brown, or orange) 407
- subrelay PCA 228
- subscribing to list server 50
- subtractive color process 126
- supplies, ordering 49, 53
- support
  - Customer Care Center (CCC) 54
  - Customer Information Centers 53
  - Customer Support Sales Center 53
  - Dealer Response Line 53
  - font 52
  - HP ASAP 52
  - HP Direct 53
  - HP FIRST 52
  - HP JetDirect 439
  - HP Software Distribution Center 53
  - list server 50
  - (support, continued)
    - technical 52
    - third-party 439
    - websites 50
  - Support Materials Europe (SME) ordering information 49
  - switches
    - black toner cartridge 175
    - carousel button 175
    - defective 378
    - delivery cover/front cover 175
    - imaging drum 175
    - names and locations 175
    - paper size detection 176
    - paper size detection (tray 2) 175
    - paper size detection (tray 3) 175
    - power 175
    - reset 175
    - right cover 175
    - test print 175
    - thermo 173
    - toner cartridge cover 175
  - switches (2,000-sheet input unit)
    - DIP 428, 430
    - names and locations 181
    - normal/diagnostic mode 182
    - paper quantity 182
    - paper quantity detection 183
    - paper size assembly 284
    - paper size detection 183
  - switches (multi-bin mailbox)
    - interlock 190, 306
    - names and locations 189
  - switching I/O 20
  - SWx. *See* switches; switches (2,000-sheet input unit); switches (multi-bin mailbox)
  - symbol sets for PCL 77

**T**

- technical assistance. *See* support
- technical training 50
- temperature
  - automatic environment change control 147
  - fusing 154
  - sensor 147
  - sensor error 323
  - specifications 21, 23
- tension springs (2,000-sheet input unit) 285
- test print switch 175
- tests
  - continuous 341
  - CRC 82
  - developer motor 83

- (tests, continued)
  - DIMM 82
  - drum motor 83
  - engine 344
  - firmware ROM 82
  - formatter video 82
  - hard disk 82
  - input trays 83
  - installation 92
  - output bins 83
  - paper path 83, 365
  - printing color pages 79
  - sensor 83
- tests (2,000-sheet input unit)
  - motor 431
  - sensor 432
  - standalone 430
- tests (multi-bin mailbox)
  - paper path 435
  - power-up sequence 435
  - standalone 434
- text resolution 20
- thermistor
  - fan 165
  - sensors 173
- thermo switches 173
- thermographic inks 33
- ThinLAN cables, using 63
- third-party support 439
- timeout for I/O 78
- timing charts
  - description 192
  - full color 11-by-17-inch sized page 197
  - full color letter-sized page 195
  - WAIT period 193
- Token Ring 446
- toner
  - background scatter 407
  - black level detection 147
  - cartridge not installed 345
  - cartridges parts lists 447
  - cleaning from fabric 87
  - cleaning from waste tray 102
  - color carousel error 323
  - color level detection 145
  - fusing process 141
  - lever unlocked 349
  - loose 405
  - low 356
  - low and out messages 75
  - out 356
  - popping 403
  - product information sheet 45
  - residual 136, 138, 140
  - safety 45
  - stray 410
- (toner, continued)
  - waste 140
  - waste level 143
- Toner Cartridge MSDS 45
- toner cartridges
  - cover switch 175
  - installing black 87
  - installing color 88
  - location 104
  - recycling 55
  - refilling 55
  - replace frequency 105
  - warranty 55
- toner lock sensor 227
- tools required for service 204
- top (face-down) output bin
  - delivery sensor 173, 178, 179
  - location 35
  - paper full sensor 173, 179
  - paper path test 83
- top assemblies 223
- top cover (multi-bin mailbox) 288
- top cover assembly 211
- top output bin
  - full 357
  - jams 339
  - multi-bin mailbox full 344
- total
  - color pages printed 80
  - duplex page count 81
  - page count 80
- training 50
- transfer belt
  - assembly 450, 487
  - control process 149
  - illustration 124
  - installing 106
  - jams 437
  - location 104
  - press clutch 177
  - repetitive defects 425
  - replace frequency 105
- transfer charger 124
  - cleaning 101
  - installing 106
- transfer drum
  - cleaning 422
  - cleaning post charger 99
  - cleaning process 138
  - damaged 335
  - illustration 124
  - jams 340
  - location 104
  - new 352

- (transfer drum, continued)
  - not installed 348
  - repetitive defects 422
  - replace frequency 105
- transfer jams 338
- transfer kit
  - installing 106
  - life detection 144
  - life low 357
  - life out 357
  - low and out messages 75
  - parts list 447
  - percentage life remaining 81
  - replace frequency 105
  - resetting life count 78
- transfer roller repetitive defects 422
- transparencies
  - automatic detection 167
  - defects 412
  - dull or dark 412
  - for ink jet printers 33
  - parts list 447
  - print speeds 20
  - process 167
  - reducing curl 378
  - sensors 167, 171, 173
  - using 31
  - See also* media
- transport belt (multi-bin mailbox) 192
- transport belt motor (multi-bin mailbox)
  - 190, 192, 294
- tray 1
  - assembly 450, 484
  - configuring 72
  - error feeding media from 328
  - illustration 124
  - last page sensor 171, 173
  - location 35
  - paper path test 83
  - paper pick-up 170, 171
  - paper sensor 171, 173
  - paper width sensor 170
  - pick-up assembly 244, 450, 483
  - pick-up roller 124
  - pick-up roller clutch 177
  - pick-up solenoid 177
  - removing 237
  - selecting mode 90
  - size 73, 358
  - type 72
  - unknown media 357
  - See also* trays
- tray 2
  - assembly 475
  - configuring 73
  - illustration 124
  - last page sensor 173
  - location 35
  - media size sensing PCA 269
  - paper level sensors 173
  - paper out sensor 173
  - paper path test 83
  - paper pick-up 168, 169
  - paper size detection switches 175
  - pick-up solenoid 177
  - sensor 173
  - See also* trays
- tray 3
  - assembly 474
  - configuring 73
  - illustration 124
  - location 35
  - media size sensing PCA 269
  - paper level sensors 173
  - paper out sensor 173
  - paper path test 83
  - paper pick-up 168, 169
  - paper size detection switches 175
  - sensor 173
  - See also* trays
- tray 4
  - configuring 73
  - jams 340
  - removing 277
  - See also* 2,000-sheet input unit; trays
- tray pick-up solenoid 169
- trays
  - capacities 28
  - configuring 72, 73, 90
  - defective switches 378
  - empty 359
  - jams 338
  - media specifications 28
  - waste toner 102
  - See also* tray 1; tray 2; tray 3; tray 4
- troubleshooting
  - 2,000-sheet input unit 426, 431
  - checklist 315
  - cold reset 376
  - configuration page 361
  - event log 364
  - image defects 386
  - image formation 383
  - media jams 379
  - message 316
  - multi-bin mailbox 434
  - network 439
  - paper path 378

- (troubleshooting, continued)
  - registration plate 399
  - repetitive defects 419
  - transparencies 412
  - See also* diagnostics; errors
- TrueType fonts 20
- typeface support 52
- types, configuring media 90, 91

## U

- unexpected
  - paper size jams 340
  - paper size/type 318
- unidirectional mode (multi-bin mailbox) 187
- unknown media 357
- unlatched multi-bin mailbox 437
- unlocked toner lever 349
- unrecoverable error 333
- upper
  - fuser heater 159
  - fusing roller 124, 141
  - VTU rollers 185
- user guide parts list 448
- user interface features 20
- user-replaceable parts 205

## V

- Value key 66
- VCCI statement (Japan) 43
- ventilation requirements 24
- vertical transfer unit (VTU). *See* VTU (vertical transfer unit)
- virtual stacker mode (multi-bin mailbox) 186
- VTU (vertical transfer unit)
  - closed sensor 182
  - clutch 182
  - door open 345
  - illustration 185
  - process 183
  - removing 275
  - rollers 185
- VX ASIC test 82

## W

- warnings
  - configuring 75
  - control panel 316
- warranty
  - printer 55
  - toner cartridge 55

- waste toner
  - cleaning 102
  - collection 140
  - feed roller 140
  - level detection 143
  - tray 102
- watermarks 33
- wavy
  - patterns 101
- websites for support 50
- weight
  - media in duplexer 31
  - media in input trays 28
  - printer 22
- wet media 403
- wheels, developer DSD 421
- width of printer 22
- wiring diagrams 440
- wrinkled pages 378
- write protected hard disk 342
- wrong page request 438

## Y

- yellow
  - dark print 413
  - detail value 79
  - smooth value 79
  - streaks 408
- yellow toner cartridge
  - installing 88
  - location 104
  - replace frequency 105







Copyright© 1998  
Hewlett-Packard Co.  
Printed in USA 10/98

**Manual Part No.  
C3983-90954**



C3983-90954



Printed on at least  
50% Total Recycled Fiber with  
at least 10% Post-Consumer Paper